

URAL

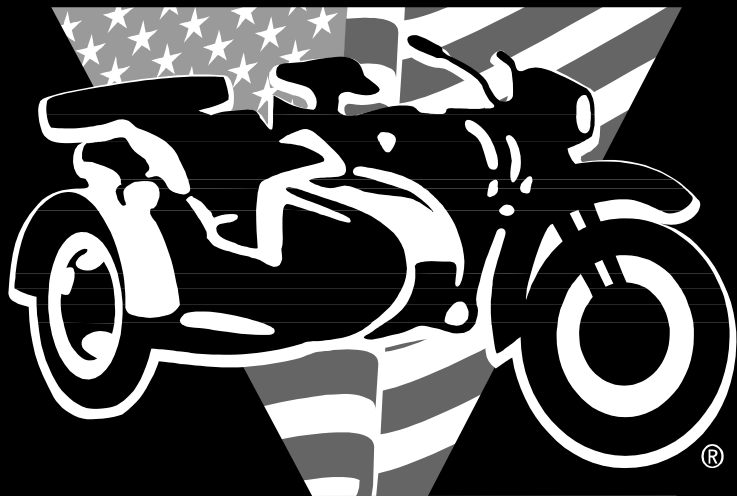

АМЕРИКА

РУССКИЕ МОТОЦИКЛЫ
MADE IN RUSSIA

TABLE OF CONTENTS

Chapter 1: General Information

1.1 URAL Specifications	1
1.2 Maintenance, Lubrication and Tune-up	6
1.3 Normal Operation	10
1.4 Troubleshooting	15
1.5 General Dismantling and Repair Techniques	30

Chapter 2: Chassis and Running Gear

2.1 Description and General Specifications	36
2.2 Operating Controls	38
2.3 Front Fork and Suspension	44
2.4 Rear Suspension	50
2.5 Brakes	51
2.6 Wheels, Tires, Shock Absorbers and Springs	54
2.7 Fenders	62
2.8 Bench Seats	62
2.9 Windshield and Fairing	62

Chapter 3: Sidecar

3.1 Description and General Specifications	65
3.2 Installation and Removal	66
3.3 Sidecar Alignment	67
3.4 Frame/Attachment	69
3.5 Suspension	70
3.6 Sidecar body	71
3.7 Handling Differences Between Single & Dual Wheel Drive	72
3.8 Driven Sidecar Wheel	73
3.9 Fender	77
3.10 Upholstery	77

Chapter 4: Engine

4.1 Description and General Specifications	78
4.2 Repair Information and Service Limits	83
4.3 Cylinder Heads and Valves	84
4.4 Cylinders and Pistons	93
4.5 Camshaft, Timing Gears, Tappets	99
4.6 Oil Pump and Delivery	102
4.7 Removing and Reinstalling the Flywheel	105
4.8 Crankshaft and Connecting Rods	106
4.9 Crankcase and Covers	112

Chapter 5: Gearbox

5.1 Description and Specifications	113
5.2 Gearbox (Solo Motorcycle)	118
5.3 Shift Mechanism Adjustment	121
5.4 Gearbox Removal and Installation	123
5.5 Gearbox Disassembly and Reassembly	124
5.6 Repairing the Gearbox Assembly Units and Parts	127

Chapter 6: Clutch

6.1 Description and Specifications	133
6.2 Clutch Adjustment	134
6.3 Removing and Reinstalling the Clutch Release Mechanism	134
6.4 Clutch Repairs	135
6.5 Clutch Reassembly	136

Chapter 7: Driveshaft and Final Drive

7.1 Description and Specifications	137
7.2 Removal and Installation of Final Drive	138
7.3 Removing and Reinstalling Propellor Shaft	138
7.4 Removing and Reinstalling the Rear Swing Arm	139
7.5 Driveshaft and Universal Joint Repair	139
7.6 Final Drive Disassembly	141
7.7 Repairing the Final Drive	143
7.8 Final Drive with Driven Sidecar Wheel (Sportsman)	145

Chapter 8: Electrical

8.1 Description and Specifications	147
8.2 Maintenance and Troubleshooting	147
8.3 Battery	149
8.4 Alternator	153
8.5 Ignition	155
8.6 Lights	158
8.7 Horn	159
8.8 Turn Signals	159
8.9 Wiring, Switches, Fuses, Connectors	160

Chapter 9: Fuel, Carburetion, Air Intake, Exhaust

9.1 Description and Specifications	161
9.2 Fuel Tank, Fuel Valve	161
9.3 Carburetors	162
9.4 Air Filter	164
9.5 Exhaust pipes & Mufflers	165

Chapter 10: Repair Supplies

10.1 URAL® Seals	166
10.2 Lubricants	166

10.3 Substitute Parts	167
Chapter 11: Conversion Tables	168
Appendix	
# 1 Wiring Schematics	169
# 2 Troubleshooting Guides.....	179

www.ClassicCycles.org

This **Repair Manual** deals with maintenance and repair of all U.S. Specification URAL[®] motorcycles.

The Repair Manual provides information on setup, tune-ups, servicing, diagnosing problems, removing and installing components (otherwise referred to as "assembly units"), overhauling components, adjusting repaired components, and testing the repaired motorcycle.

The increasing competition in the motorcycle market requires, more than ever, careful attending to the customer in order to assure the owner satisfaction with one's motorcycle and to maintain customer confidence in the dealer and factory.

It is important to repair the client's vehicles correctly in a well organized and clean repair shop equipped with all necessary tools and parts. In such an environment, and having been trained at the technical training course, a repair technician will prove to be competent and efficient.

Repairs on the engine and transmission especially, should be carried out in dust-free places. During breaks, disassembled transmissions and openings leading to the inner engine parts or lubrication holes should be protected from dust by clean rags.

Valves, valve springs, spring retainers, rockers, pushrods, tappets, pistons, connecting rods and bearings should be put away in suitable boxes. Disassembled parts have to be cleaned and thoroughly checked for the following:

Sliding and rolling surfaces for wear and freedom from scoring marks, all metal parts, particularly castings, tempered parts and welded joints as well for cracks and corrosion, and rubber parts for suitability.

As a rule, all gaskets and tab washers are to be replaced upon reassembling.

When disassembling parts, attention has to be paid to the arrangement of lock-washers on screws and nuts, spacing washers, gaskets, rubber mounts and so on. If necessary, mark mating parts in order to guarantee correct assembly.

As the reassembly has to be carried out precisely in the reverse order, it has not been considered necessary to separately explain the assembly.

Proper service and repair is important for the safe, reliable operation of all mechanical products. The service procedures recommended and described in this Service Manual are effective methods for performing service operations. Some of these service operations require the use of tools specially designed for the purpose. These special tools should be used when and as recommended.

It is important to note that some warnings against the use of specific service methods, which could damage the motorcycle or render it unsafe are stated in this Repair Manual. However, please remember that these warnings are not all inclusive. Since Ural could not possibly know, evaluate and advise the service trade of all possible ways in which service might be

done or of all the possible hazardous consequences of each way, we have not undertaken any such broad evaluation. Accordingly, anyone who uses a service procedure or tool which is not recommended must first thoroughly satisfy himself that neither his nor the operator's safety will be jeopardized by the service methods selected.

Wear eye protection while using any of these tools: hammers, arbor or hydraulic presses, gear pullers, spring compressors, and slide hammers. Be especially cautious when using pulling, pressing or compressing equipment. The forces involved can cause parts to "fly-out" with considerable force and cause bodily injury.

www.ClassicCycles.Org

GENERAL INFORMATION

1.1 SPECIFICATIONS

***Note: -10 Models are Deco Classics**

GENERAL	TOURIST / SPORTS UTILITY/ *-10 Mdl's	SOLO
Maximum speed of motorcycle	108 km/h / 65 mph *119km/h / 74 mph	122 km/h / 77 mph
Reference fuel consumption at 85% of maximum speed	12.5 km/l / 29 mpg 14 km/l / 32.5 mpg	16.7 km/l / 39 mpg
Dry mass of motorcycle	700 lb. / *680 lb.	460 lb.
Maximum load-carrying capacity	500 lb/485 lb/*400 lb	330 lb.
Noise level	below 80db	

OVERALL DIMENSIONS OF MOTORCYCLE

Length	2500 mm / 8 ft	2200 mm / 7 ft
Width	1700 mm / 5 ft 6 in	850 mm / 2 ft 8 in
Height	1100 mm / 3 ft 6 in	1060 mm / 3 ft 8 in
Road Clearance	125 mm / 5 in	
Seat height	840 mm / 33 in	810 mm / 32 in
Wheel base	1470 mm / 55 in	

ENGINE

Type	4 stroke, overhead valves, opposed twin-cylinder	
Displacement	649 cc	
Cylinder bore	78 mm / 3.07 in	
Piston stroke	68 mm / 2.68 in	
Compression ratio	8.5	
Rated horsepower	35	
Rated rotational speed	5600 RPM	
Rated torque, Nm	45 Nm / 398.7 in-pound	
Ignition system	Contactless with electronic ignition timing	
Lubrication system	Dual system of forced lubrication and by splashing	
Lubricant	SAE 20W/50 (see Owner's Manual Maintenance Section)	

CARBURETOR

Carburetor type	Keihin Seiki 32 CVK
Number of carburetors	2
Air cleaner	Pleated Paper Filter
Fuel	91 octane premium unleaded gasoline
PCV Valve	Internal Breather

ELECTRICAL EQUIPMENT

Ignition system	12 V
Ignition coil	B204
Spark plugs	NGK BP7HS or NDW20FP-1
Ignition timing	Automatic spark timer
Power supplies	Alternator
	Storage battery (Russian supplied with new motorcycle)
	Recommended replacement: Interstate #12N9-4B-1
Voltage regulator (electronic)	Internal to Alternator
Horn	C205B
Headlight	URAL® part no. UA-TB6014-017 Sylvania Incandescent 6014, 7" round sealed beam

TRANSMISSION

Clutch	Dry double-disk clutch
Gearbox	4 speed box with reverse gear (no reverse for solo model) and gear shifting foot pedal

GEAR RATIOS

	<i>TOURIST / SPORTSMAN / UTILITY</i>	<i>SOLO/CRUISER</i>
I gear	3.6	3.6
II gear	2.28	2.28
III gear	1.7	1.7
IV gear	1.3	1.3
Reverse gear	4.2	N/A on Solo 4.2 on -10 mdl's
Speedometer drive ratio	0.4	0.5
Final drive	Pair of bevel gears with propeller shaft	
Final drive ratio	4.62	3.89

FLUID CAPACITIES

	<i>TOURIST & -10 Models</i>	<i>Sportsman</i>	<i>Solo</i>
Gasoline tank	19 L / 5 Gal	19L / 5 Gal	18.5 L / 4.9 Gal
Reserve	2L / 0.5 gal	2L / 0.5 gal	2L- / 0.5 Gal
Engine crankcase	2 L / 2 qt. + 3.6 oz.	2.0L / 2.11 qt	2 L / 2 qt. + 3.6 oz.
Gearbox	0.9L / 1 qt	0.9L / 1 qt	0.9L / 1 qt
Final drive	110 ml / 3.85 oz.	150 ml / 5.25 oz.	110 ml / 3.85 oz.
Telescopic Forks (-10 & solo models)	N/A on Tourist	N/A on Sportsman	135 ml / 4.56 oz.
Shock Absorbers	105 ml / 3.55	105 ml / 3.55 oz	105 ml / 3.55 oz

RUNNING GEAR	TOURIST / SPORTSMAN	SOLO
Frame	Tubular welded	
Rear wheel suspension	Swing arm with hydraulic spring shock absorbers	Sidecar: same as -40 Solo: Lower spring rate
Front fork	Leading link	Telescopic spring
Sidecar	Cushioned body (on rubber cushions) and wheel on long-lever suspension with hydraulic spring shock absorber	N/A
Brakes	Shoe-type with mechanical drive on front, rear and sidecar wheels, front wheel has dual cams.	
Tires	4" x 19" Front & Side: 22 psi cold Rear: 36 psi cold	3.5" x 18" Solo: Front 25 psi cold Rear: 32 psi cold -10's: Front & side: 25 psi cold Rear: 36 psi cold

CLEARANCES	mm	in
Valves with engine cold	0.05	0.002
Between spark plug electrodes	0.50 - 0.65	0.020 - 0.026
Between brake shoes and drum	0.3 - 0.70	0.012 - 0.028
Backlash between tooth faces of bevel gears in final drive	0.1 - 0.3	0.004
Between rotor and ignition pickup	0.3 - 0.4	.012 - .016

FREE TRAVEL / ADJUSTMENTS	mm	in
Hand brake control lever	5 - 8	0.2 - 0.3
Clutch control lever	5 - 8	0.2 - 0.3
Foot brake drive pedal	¼ of full stroke of pedal, 25 - 30	1.0 - 1.2
Toe-in throughout motorcycle center distance (exception: Sportsman 0° toe-in)	10	N/A
Angle of motorcycle inclination to vertical plane (camber angle of rear wheel)	1° away from sidecar	N/A
Headlight installation (with motorcycle laden)	horizontal (high beam)	

TORQUE SPECIFICATIONS

Metric (in repair manual)	US Equivalent	Location on Bike
29 to 33 Nm	22 ft/lb. to 30 ft/lb.	cylinder heads
22 to 25 kgf-m	175 ft/lb. to 185 ft/lb.	fly wheel tightening screws
3.8 to 4.2 kgf-m	30 ft/lb. to 40 ft/lb.	cylinder
2.1 to 3.0 kgf-m top	14 ft/lb. to 22 ft/lb.	shock absorber
3.6 to 5.0 kgf-m bottom	28 ft/lb. to 36 ft/lb.	shock absorber
3.0 to 3.4 kgf-m	22 ft/lb. to 26 ft/lb.	bearing nut
3.0 to 3-4 kgf-m	22 ft/lb. to 26 ft/lb.	final drive to swing arm bolts
1.6 to 1.8 kgf-m	12 ft/lb. to 14 ft/lb.	oil pump bolt
.8 to 1.0 kgf-m	5 ft/lb. to 8 ft/lb.	engine sump
1.4 to 1.8 kgf-m	10 ft/lb. to 14 ft/lb.	final drive case nuts
7 to 9 kgf-m	50 ft/lb. to 66 ft/lb.	nut fastening the pinion bearing
2.2 to 2.8 kgf-m	16 ft/lb. to 20 ft/lb.	reverse gear brake lever
1.8 to 2.0 kgf-m	14 ft/lb. to 16 ft/lb.	generator gear nut
14.0 to 16.8 kgf-m	100 ft/lb to 120 ft/lb	steering stem nut

CONVERSIONS

To convert from mm to in, divide by 25.4 (there are 25.4 mm per inch).

To convert from liters to gallons, divide by 3.785 (there are 3.78 liters per gallon).

To convert from liters to quarts, multiply by 1.056 (there are 1.056 quarts per liter).

To convert from liters to pints, multiply by 2.112 (there are 2.112 pints per liter).

To convert from km to miles, multiply by .62 (there is .62 mile per km).

To convert from km/hr to mph, multiply by .62.

To convert from Newton-meter (Nm) to inch-pound, multiply by 8.86.

To convert from cm^3 (cc) to pints, divide by 473 (there are 473 cc per pint).

To convert Celsius to Fahrenheit, $F^\circ = C^\circ \times 1.8 + 32^\circ$.

To convert Fahrenheit to Celsius, $C^\circ = (F^\circ - 32^\circ) \text{ divided by } 1.8$

CAUTION: During the initial 2,500 km of use a fundamental bedding-in of parts for all the mechanisms of the motorcycle takes place. During this period do not overload the engine or race the motorcycle in excess of the speeds specified in the section "Running-In of New Motorcycle." Doing so will void the warranty.

Each URAL® motorcycle is supplied with an individual tool kit, including documentation, as follows.

Tools

Wrench 7 x 8 mm
Wrench 10 x 12 mm
Wrench 13 x 14 mm
Wrench 14 x 17 mm
Wrench 19 x 22 mm
Socket wrench 10 x 12 mm
Socket wrench 10 x 13 mm
Socket wrench 19 x 21 mm
Wrench 27 mm
Double head wrench
Spanner wrench
Spanner wrench assembly
Screwdriver 150 mm
Screwdriver 100 mm
Pliers
Tool kit pouch

Set of Spares

Inner tube patch kit
Oil filter element
Kick starter pedal sleeve
Fuses

Documents

Owner's Manual
Driving the URAL® Sidecar Manual
(except with Solo models)
Owner's Video

Accessories

Air Pump
Air Pressure Gauge
2 Ignition keys

1.2 Maintenance, Lubrication, & Tune-up

Maintenance Intervals

Maintenance intervals recommended are based on operational experience under various climatic and road conditions. However, these intervals may be extended or reduced following repeated checks of the lubricant condition and general technical condition of the motorcycle.

In certain sections of this manual you will find references to more frequent maintenance intervals than the "Light Duty" minimal maintenance intervals referred to in the Maintenance Schedule Summary. The sidecar motorcycle requires adherence to the "Normal Duty" maintenance schedule.

Maintenance Schedule Summary

The following schedule is broken into two columns to indicate the type of usage and operating environment to which the machine will be subject. The "**Normal Duty**" category includes operation in dusty, hot climates, while pulling loads on hilly terrain for significant periods of time in the maintenance cycle, operation primarily with the sidecar accessory attached or for owners who want to take extra care to keep their machines in "tip top" condition.

The "**Light Duty**" schedule is the minimal maintenance that an owner should perform to keep the factory warranty in place. It is acceptable when the machine is used primarily in ideal climates with very little dust or contamination of fuel supply and with sidecar accessory unattached.

Maintenance Schedule Summary

1. Change motor oil, clean or replace oil filter element, clean air filter element and fuel filter, check bearings play. Check electronic ignition pickup air gap. Adjust throttle, clutch and brake cables, and check gearshift linkage for adjustment. Check battery fluid.

At 500km then every 2,500km

2. Change gearbox oil, replace oil filter, and rotate tires.

Every 5,000km

3. Lubricate drive axle/hub, replace final drive gear oil.

Check level every 2,500km,

Replace at 500km and every 10,000km

4. Replace spark plugs, torque cylinder head stud nuts, adjust valve lash, re-pack wheel bearings, and check ignition timing.

Every 10,000km

Table 1.2-1**Lubrication Chart**

Item	Part To Be Lubricated	Lubricant	Schedule
1	Lever pin and interrupter felt Pins and weight holes, automatic unit cam bushing	Industrial oil or spindle oil	Every 5,000 km Every 5,000 km
2	Engine crankcase Oil filter	20w/50 Det. oil and URAL® Oil Treatment	Every 2,500 km ¹ Every 5,000 km
3	Gearbox	20w/50 Det. oil and URAL® Oil Treatment	Every 2,500 km ²
4	Air cleaner	Spray WD-40	Wash and oil every 2,500 km
5	Shock absorbers of rear suspension and sidecar wheel suspension	Industrial oil or spindle oil	Change every 10,000 km
6	Final drive	80/90 wt. Gearlube and URAL® Oil Treatment	Top up every 2,500 km ³ , change every 10,000 km
7	Hinges of sidecar collet joint	Grease	Every 10,000 km
8	Hinge joints of brake system	Spindle oil/WD-40	Every 5,000 km
9	Brake pedal shaft	Spindle oil/WD-40	Every 2,500 km
10	Universal joint of propeller shaft (grease cup)	Grease	Every 10,000 km
11	Lever pins and end pieces of clutch and hand brake cables Clutch, front brake and throttles control cables	Grease Spindle oil/WD-40	Every 5,000 km Every 5,000 km
12	Pins and cams of brake shoes	Grease	Every 5,000 km
13	Wheel hub	Grease	Every 10,000 km
14	Front fork dampers (lubrication points)	Spindle oil/WD-40	Change every 10,000 km
15	Carburetor throttle control twist grip	Grease	Every 5,000 km
16	Speedometer drive flexible shaft and speedometer axle	Industrial oil or spindle oil	Every 10,000 km
17	Steering column bearings	Grease	Every 20,000 km
18	Telescopic forks (-10 and Solo)	5 wt. -10 wt. Fork Oil	As needed

1. After break-in, changes required at 500km, 2,500km, 3,500km and 5,000km.
2. During break-in, change at 500 km and then 2,500km.
3. During break-in, change at 500km.

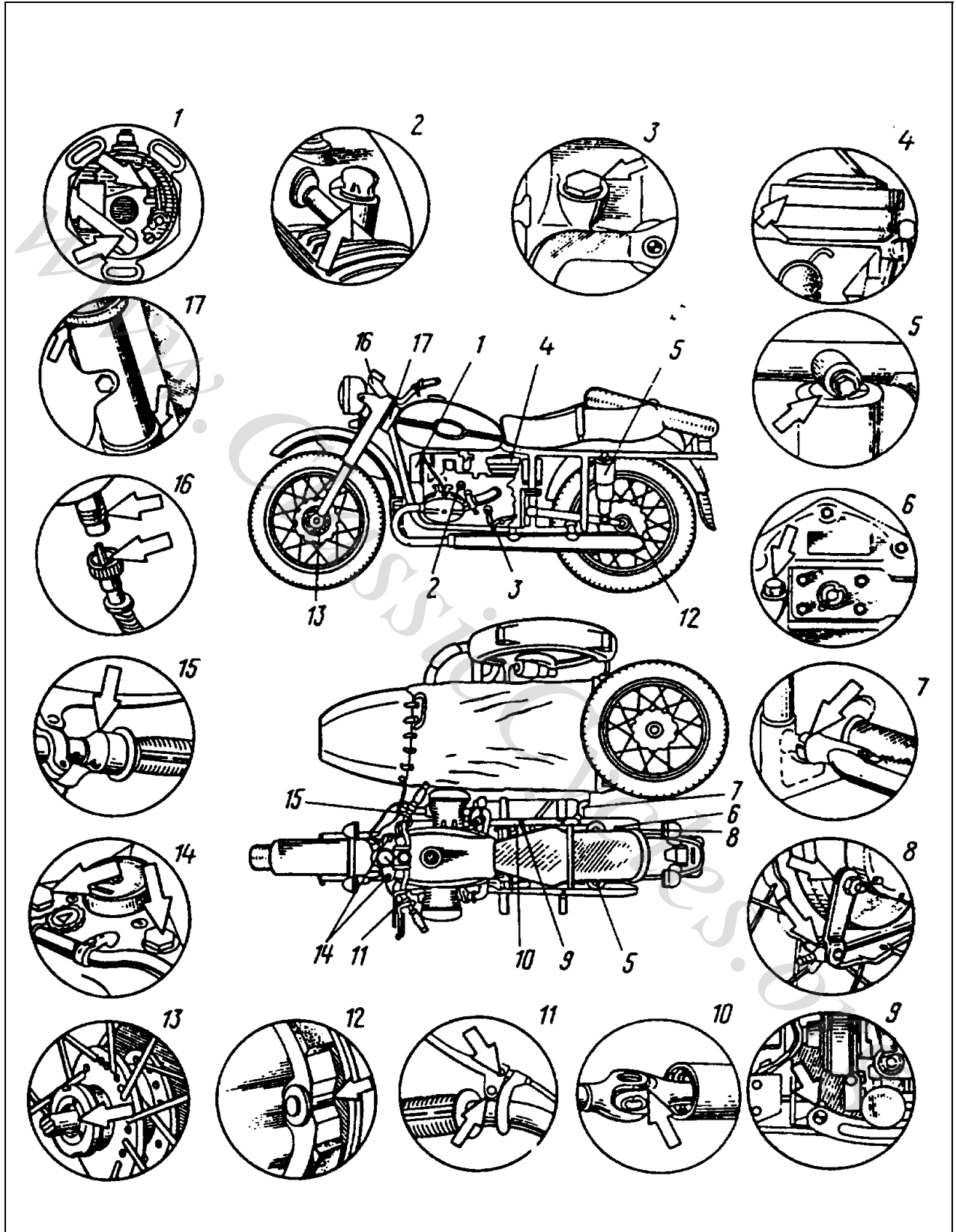

Table 1.2-1 (cont'd) Lubrication diagram

Control Cable Maintenance

The daily preventive maintenance involves checking the functioning of the cables, the condition and fastening of the tie rods and cables and braking action. Refer to the maintenance summary for lubricating and schedule.

After every 5,000 km, check the condition of the brakes, clean the brake shoes and the active surface of the brake drums, lubricate the hinge pins and the cams of the brake linings, the joints, the linkage of the rear and sidecar wheel brakes, lever axles, the parking brake bearing, the throttle control twist grip, the lever pins and ends of cables used in the clutch, the front brake control, the control cables used in the clutch, the front brake and the throttles.

Motor Oil

The URAL® has been certified for EPA with premium grade SAE 20W/50 petroleum based detergent oil rated for air-cooled engines.

This oil can be used in both the engine and transmission. The Authorized URAL® Dealer should be prepared to make recommendations for all lubricants best suited to local conditions.

For operation below 32° F, SAE 10W/40 oil is recommended.

Tune-up

To help prolong the service life of the motorcycle, it is essential to inspect the machine frequently and make repairs promptly as they are discovered. A machine that has had little or no periodic service may be very difficult to diagnose and repair when a problem does occur.

In addition to the following, top off all lubricants and adjust running gear and sidecar alignment.

As a minimum, check and adjust:

- spark plug gaps
- valve clearances
- throttle synchronization
- clutch
- adequate fuel quantity, condition, and flow
- acceptable quantity and condition of oil in the engine crankcase, gearbox, and final drive
- pick up and rotor gap
- carburetors
- brake controls
- drive housing
- all switches and lights functioning
- battery condition and charge

1.3 Normal Operation

This section describes techniques and precautions for operating a URAL® motorcycle, including break-in procedures for new or rebuilt engines.

Pre-ride Preliminaries

Before each ride, attend to all the requirements of the everyday maintenance as outlined in this manual. When filling the motorcycle with fuel and oil, take care to avoid spills that might damage the machine or create safety or environmental hazards. The fuel tank should not be overfilled. Overfilling can result in fuel leakage during operation. Always check engine oil level before starting the engine.

CAUTION: When checking or topping off lubricants use caution to prevent dirt and debris from falling into the fill opening. When using funnels, tubes, pumps, etc., ensure they are not contaminated with dust or dirt. When draining oil, use care to prevent oil from contacting wheels, tires, or brakes, and avoid skin contact with used oil.

Starting The Engine

WARNING: Before starting the engine, make sure that the gear shift mechanism is in the neutral position (between I and II gears) to prevent sudden accidental movement which could cause possible damage to motorcycle and personal injury. For sidecar motorcycles equipped with a reverse gear, make sure that reverse is not engaged.

If ignition is switched on, the green neutral light on the instrument panel should illuminate when the transmission is in neutral, however, the neutral light will also be on if the motorcycle is in reverse gear. Check to be sure that the reverse lever is in the forward position, or manually roll the motorcycle forward and back to ensure that both transmission and reverse are in neutral before starting.

Open the fuel petcock by setting its handle to the down position.

NOTE: For URALs manufactured earlier than mid-95, the down position is off. This type of valve has a flatter / wider blade than the later valves. If in doubt, verify fuel flow by removing the fuel line at the carburetors. (Reserve is up and off is horizontal.)

Getting a URAL® engine started is an art that must be mastered. Owners may need to be coached through the process. The use of throttle and carburetor enrichment is critical for successful starting, as is a fully-charged battery. Depending on the engine and ambient temperatures, use the carburetor enrichers and starting procedure as follows.

Starting A Warm Engine

When the engine is hot, do not enrich the carburetors. To do so risks flooding the engine. Turn on the ignition, check the cutoff switch in the run position, select neutral gear, and push down on the kick

lever just far enough to engage it; about 1/4 of its travel. The standard Russian position for starting the sidecar motorcycle is standing on the passenger peg on the right foot, and stepping down on the kickstarter with the ball of the left foot. Take up the slack in the throttle until you can feel some slight resistance from the return springs in the carburetors. However, do not advance the throttle, since this may flood the engine.

Step down swiftly on the kickstart lever and give it a full stroke to the bottom stop. If the engine starts, tickle the throttle (rapidly twist part way towards full throttle and then back off) to keep the engine running, but don't allow it to rev up.

WARNING: Once the engine starts, do not allow it to rev beyond 2,000 rpm while cold, which may lead to seizure of the piston pin and pistons in the cylinders. Cold oil flows through the oil ducts more slowly and cannot provide sufficient lubrication.

A correctly adjusted warm engine should run steadily at low speed with the throttle control twist grip fully closed. Start driving the motorcycle only after having warmed up the engine, with the engine running steadily at low speed. In cold seasons do not run the engine at high RPM during initial 3 km or drive at a speed exceeding 30 mph until the engine is fully warmed up.

If the engine doesn't start on the first kick, kick it through aggressively, four or five times. A properly adjusted warm engine should start within a few kicks. If the engine doesn't start, or coughs, that indicates it is cold enough to require some enriching of the mixture. However, it may also be flooded.

Flooded Engine

To start an engine that is flooded pull out both enrichers, open the throttle fully, hold it there and kick the engine through several times. It should fire. As soon as it fires, return the throttle to just above idle to keep it running. If it still doesn't fire, take the spark plugs out to see if they are very wet with gasoline. If they are wet, dry them, and clear excess gasoline from the cylinders by kicking the engine over several times with the plugs out and the throttle closed. Then replace the plugs and repeat the starting procedure using no enricheners.

Cold Engine, Warm Day

When the engine has been standing for several hours but the ambient temperature is high (60°F or above), it will probably start without enrichment. If it doesn't fire, use one of the following procedures.

Cool Engine, Cool Day

When the engine is cool or cold and the ambient temperature is between 40-60 F, pull out both enricheners. As soon as the engine starts, immediately push both enricheners back in. Run the engine at moderate speed for 30-60 seconds. If it starts to die, tickle the twist grip throttle (rapidly twist part way towards full throttle and then back off) to keep the engine running. After 1 to 3 minutes, depending on ambient temperature, the engine should run smoothly.

Cold Weather Starting

If the engine is cold and ambient temperature is below 40 degrees F, first, give the engine 5-10 (depending on how cold it is) priming kicks with the ignition off. This will get some oil circulated to key internal parts. Pull open the enricheners on both carburetors. The engine should then soon fire, depending on how cold it is. For example, when the ambient temperature is 0 degrees F, it typically takes about 3 to 5 seconds to start the engine. As soon as the engine starts, push in both enricheners. Then follow the running procedure described in **Starting the Engine** (also in section 1.3).

NOTE: It is very important to back off on the enricheners as soon as the engine will sustain itself without sputtering. The URAL[®] can foul plugs quickly (as soon as one minute) if the engine is run too rich. If one plug fouls and the other doesn't, the engine will run very unevenly and have greatly reduced power.

WARNING: Sustained operation on only one cylinder for even just a few minutes could overheat the cylinder and cause irreversible damage to either the valves or piston. Thus it is critical to immediately shut the engine down if it appears to be running on only one cylinder.

Operating Precautions

WARNING: Make sure that sidecar windshield is in the full back position and it doesn't interfere with the right handlebar.

To move the motorcycle from rest, shift to the 1st gear only. Avoid releasing the clutch suddenly, because the engine is liable to stall or the motorcycle will start with a jerk.

Do not drive the motorcycle at speeds below the recommended speeds with the 2nd, 3rd or 4th gears engaged. It is not advisable to use the 1st and 2nd gears for a long time, unless so required by road conditions.

WARNING: When shifting to lower gears with the motorcycle in motion, do not downshift at speeds higher than those listed in the table. Shifting to lower gears when speed is too high may severely damage the transmission or cause the rear wheel to lose traction.

Shift to neutral before shutting off the engine. The shifting mechanism can be damaged by attempting to shift the transmission when the engine is not running. When engine speed decreases, as in climbing a hill or running at a reduced speed, change from a higher gear to the next lower gear while partially closing the throttle.

CAUTION: Do not run the engine at extremely high rpm with clutch disengaged or transmission in neutral. Do not idle the engine unnecessarily for more than a few minutes with the motorcycle standing still. Remember the URAL® engine is an air cooled engine which requires the movement of air to keep the engine at normal operating temperatures and to avoid overheating the cylinders.

An engine run long distances at high speed must be given close attention, to avoid overheating and consequent damage. The engine should be checked regularly and kept well tuned. Valve seating and good compression is particularly important, especially for a sidecar motorcycle equipped with windshields, carrying heavy loads, or operating in hot weather.

WARNING: When riding on wet roads or under rainy conditions, braking efficiency is greatly reduced and caution should be used when applying the brakes, accelerating and turning. This is especially true immediately after the rain begins and the oil from the road surface combines with the water.

When descending a long, steep grade, downshift and use engine compression together with intermittent application of both brakes to slow the motorcycle. Drum-type brakes tend to overheat and fade if used continuously.

Shutting Down an Overheated Engine

An overheated engine can backfire or detonate when being shut down. The engine jerking at low speeds is hard on both the engine and the transmission. To avoid damage when shutting down an overheated engine, reduce the engine speed to the minimum and completely close the choke without switching off the ignition. This will make the engine stall without any knocks or backfire. After the engine stops, switch off the ignition.

Running In a New Motorcycle

URAL® motorcycles require a running-in period to allow new parts such as bearings to seat. The running-in period also applies to new or overhauled components. Since the URAL® engine is an old fashioned design it is critical to observe this running-in procedure. Failure to follow the running-in procedure will void the Ural warranty.

During the running-in period, a new motorcycle requires the most careful attention. In the course of this period, do not overload the machine, avoid traveling on freeways and climbing steep upgrades. Do not race the engine or allow it to overheat at any time.

Pay special attention to lubrication of the engine. It is recommended that after the initial 500 km, the break-in oil be drained, the crankcase flushed, and refilled with fresh oil to the correct level. Transmission and final drive lubricants can be changed per the normal maintenance schedule summary.

The running-in period for the motorcycle is divided into two stages, up to 1,000 km and from 1,000 up to 2,500 km. When running-in, keep the speeds within the limits stated in the following Table. Even on a thoroughly run-in motorcycle, Ural advises not exceeding the listed maximum speeds:

Table 1.3-1 SPEEDS NOT TO EXCEED FOR RUNNING-IN

Gear	Tourist (-40) & Patrol		Solo & Cruiser (-10)	
	0 - 2,500 km	After Run-In	0 - 2,500 km	After Run-In
I	9 mph	12 mph	10 mph	15 mph
II	21 mph	27 mph	22 mph	31 mph
III	30 mph	39 mph	40 mph	74 mph
IV	42 mph	65 mph	50 mph	70 mph

1.4 Troubleshooting

Troubleshooting

Although some parts may fail suddenly, most parts degrade gradually and troubles that develop over a period of time tend to go unnoticed by the owner. The engine may gradually lose power as the cylinders lose compression. Oil and fuel consumption gradually increase. Noises gradually get louder. Seals may start to weep oil, or hoses begin to disintegrate. Metal parts form corrosion and rust. All of this degradation affects the operation and serviceability of the motorcycle.

When a machine is brought in for repairs, the relative condition of the motorcycle should be determined by inspection and by operational testing and measurement if needed. Allowing a machine with obvious defects to leave the shop exposes the shop to potential liability. The motorcycle owner may assume the shop has inspected the machine for defects as well as repairing specific problems.

Inspection

Look over the motorcycle carefully to see that all the equipment is complete, especially frame fasteners, wiring, controls, suspension and brakes. Look for lubricant leakage from seals, including engine, transmission, final drive, wheel bearings and shock absorbers. The following outline may serve as a guide.

A. Frame

- no significant dents, cracks or corrosion
- condition of the fender
- frame joints for correct fasteners and proper tightening

B. Fuel tank

- no leaks from welded seams and joints
- proper function of the fuel valve
- hoses intact and in acceptable condition
- no major dents or corrosion of fuel tank

C. Electrical equipment

- operation of the ignition switch, turn indicators, stop light switch, neutral light, alternator light, high beam indicator, headlight, and horn
- condition of all wiring and plug-and-socket connections

D. Controls

- handlebar twist grip and levers
- throttle control twist grip for easy rotation
- condition of cable armor and internal cables, particularly the end fittings

E. Wheels

- acceptable wear of the brake drum inner surface
- tire wear and condition
- axial play and radial runout of the wheel rim and tire
- no cracks or dents in the wheel rim
- running condition of the wheel hub bearings
- the wheel spokes for uniform tension

NOTE: Wheels are best inspected by alternatively jacking each wheel off the floor and rotating the wheel while observing runout of the rim and tire. Check wheel bearings by rotating the wheels and attempting to rock them laterally on the bearings. The wheels should rotate freely without noticeable play, seizing, clicks or growling, and there should be no play in the bearings. A quick test of spoke tension is to tap each spoke with a screwdriver as the wheel is rotated. The pinging sound should be relatively uniform from spoke to spoke. The tolerated axial or radial runout of the rim is 0.060 inch / 1.5 mm. The tolerated runout of the tire (radial or axial) is 0.120 inch / 3 mm.

F. Front fork

- no play in the steering head bearings
- no play of the leading link in the fork legs
- springs not broken or seized
- shock absorbers not leaking fluid
- acceptable condition of casings and guards

NOTE: The fork should rotate freely in the steering column without any noticeable play, clicks or notching. The tolerated play of the bottom tips of the fork legs should be within 0.020 inch / 0.51 mm, with the front portion of the motorcycle left in suspension.

G. Suspension

- smooth operation when bounced
- no leaks of fluid from the shock absorbers
- good condition of the silent blocks
- no play or noise in the joints

NOTE: The suspension arms and shock/springs should all function smoothly, without jamming or binding.

H. Clutch

Check the clutch mechanism both at rest and with the engine running. With the engine not running, squeeze the clutch and depress the kickstarter; the engine should not turn over.

- separation of disks when the clutch is squeezed
- no abnormal noises when the clutch is squeezed
- smooth engagement of the clutch when released
- no slipping of the clutch under acceleration

I. Kick starter

- proper engagement of the kickstarter pawl
- starter turns engine without pawl slipping
- kickstarter lever quickly returns to top when released

J. Driveshaft (Propeller shaft) and final drive

(* (Sportsman sidecar Drive Shaft)

- no excessive play or noise in the flexible coupling joints, universal joint or final drive gears
- runout of the driveshaft within limits
- acceptable condition of the flexible coupling
- proper tightening of the fastening joints
- * Safety bolts and safety wires intact
- * Tightness of differential cover nuts
- * Straightness of drive shaft

NOTE: The tolerated play in the final drive gearing should not exceed 0.012 inch / 0.3 mm. Driveshaft (propeller shaft) runout is tolerated within 0.040 inch / 1 mm.

K. Exhaust system

- tightness of joints
- no major dents or damage
- no rust holes in mufflers

L. Sidecar

- no abnormal noises in body-to-frame joints
- rubber cushions supporting body intact
- no cracks, major dents, or rust-through in sidecar frame, swing arm, fender, or sidecar body
- sidecar-to-motorcycle connections tight.
- sidecar wheel bearings in acceptable condition and adjustment
- sidecar brake functional.

When inspecting the motorcycle, observe the condition of the paint and anticorrosive coatings of the parts. In particular, watch for corrosion under the battery area that could indicate leaking battery acid. Corroded areas should be cleaned, neutralized, primed, and painted to retard further damage.

Operational Testing and Measurement

A mechanic experienced with the URAL® should be able to quickly determine the condition of an engine by feeling for hot spots, listening for abnormal noises and knocking of a running engine using a stethoscope and for condition of running gear by observing coasting ("free-wheeling") distances. Abnormal noises can be good indicators of potential failures. Table 1.4-1 lists principal noises and knocks as they relate to probable mechanical problems. Table 1.4-2 is a troubleshooting chart to help diagnose problems with specific tests.

The compression in the engine cylinders can be determined approximately by feeling resistance to cranking as the start lever is pushed down and more specifically by measurement with a compression gage. If compression is weak, adjust valve clearances, then measure the compression both "dry" and "wet" with oil, kicking the engine over the same number of strokes each test with the opposite spark plug removed.

Dry compression should be at least 100 psi / 700 kPa with no greater than 20 psi / 140 kPa difference between cylinders. If the compression increases when the cylinder is lubricated with additional oil, that indicates worn rings. Low compression both "dry" and "wet" indicates leaking valves.

A test ride can quickly help determine the condition of the motorcycle, the operation of clutch, gearbox, final drive, brakes, and suspension. Prepare to ride, start the engine, release the clutch and shift into 1st gear the motorcycle should not lurch forward. As the clutch lever is smoothly released. The motorcycle should begin to move ahead smoothly, without lurching. With the clutch fully released, quickly roll on the throttle. The motorcycle should immediately pick up speed without the clutch slipping. The gearbox should shift smoothly without jumping out of any gear. When stopping, the brakes should apply smoothly with no abnormal noises or jerking. With the transmission in neutral, shifting to reverse should not take excessive effort and the machine should back up without jerking.

Lubricated bearings should not exhibit significantly greater heating than the rest of the housing. Localized overheating (hot spots) adjacent to bearing locations indicate probable bearing failure. It is normal for large gears such as those in the final drive to warm up the housing during operation, but not get hot to the touch.

Minor oil weeping from joints and seals is considered normal. However, oil dripping or dribbling from a housing in sufficient quantity to form a several inch diameter puddle under the machine overnight is considered "significant."

If there is a question whether low performance is caused by running gear or low engine power output, a coast-down test can help isolate the problem. To measure the coast-down distance, ride the fully laden motorcycle on a straight, level, paved road section (a smooth asphalt or concrete highway), preferably in dry and calm weather. At a steady speed of 30 mph / 50 kmph, squeeze the clutch and let the motorcycle coast to a complete stop. For a URAL® in good repair the coasting distance should be at least 500 feet / 150 meters.

Engine performance can also be measured by a brief maximum speed test on a section of straight, level pavement. A URAL®, equipped with a sidecar, in good condition should easily maintain over 55 mph / 90 kmph.

As a comparison, if coasting distance is shorter than normal, that indicates problems such as dragging brakes, dragging clutch, worn wheel bearings, final drive bearing failure or sidecar out of alignment. If the coasting distance is normal, but the engine won't exceed 55 mph, the engine needs at least a tune-up and maybe repair.

Normal fuel consumption of a URAL® on level pavement at 55 mph should be approximately 2 gallons / 7.8 L per 100 km for the sidecar outfit, and 1.5 gallons / 6 L per 100 km for a solo machine. Fuel mileage decreases as engine performance deteriorates.

Normal oil consumption should not exceed 1 pint / 250cc per 200 km. Rising oil consumption indicates worn rings, worn valve guides or leaking engine seals. Owners who record fuel mileage and oil consumption may be able to provide such data to the shop.

Table 1.4-1 Determining the technical condition of engine by discerning principal noises and knocks

<i>Zone where knocking is audible</i>	<i>Nature of knocks</i>	<i>Point (joint of parts) where knocking is possible</i>	<i>Thermal condition of engine</i>	<i>Engine running duty</i>	<i>Conclusion about fitness for further service</i>
Cylinder area	Clear sharp metallic clink	Piston pin to connecting rod small end	Warm	Under load with sudden transfer to higher speed	Discontinue motorcycle operation. Should knocks disappear if the ignition is retarded, adjust ignition timing. If this does not help, remove carbon deposit from combustion chamber and, if need be, replace piston pin, selecting one to match the color marking of connecting rod small end.
Ditto	Knocking is less clear and becomes louder once engine heats up	Piston pin to piston boss	Ditto	Ditto	Ditto
	Brittle metallic clink which increases with speed variation and becomes less audible when engine is warmed up.	Piston to cylinder	Cold	Idle speed	Continue operation, if clink disappears after warming-up of engine. When repairing, replace piston.
	Similar knocks are audible when piston pin gets seized in connecting rod small end.				Discontinue operation. Replace piston and piston pin.
Central portion of engine crankcase	Dull knocks of medium volume	Connecting rod big end to crankpin	Random	At idle speed and especially when motorcycle "drags" in travel with throttle valve lowered only partially	Discontinue operation. Repair the engine.
Engine crankcase at points of bearing location	Dull low-tone knocks	Main bearings to crankshaft	Warm	Under load and once throttle valves are suddenly open	Discontinue operation. Repair the engine.
In the area of gears location	Frequent (clattering) metallic rolling rattling (inconstant as to its tone)	Timing gear	Ditto	Idle running	Operation is possible. When repairing engine, replace faulty gears.
Cylinder heads	Frequent ringing knocks which increase with speeding up irrespective of engine load	Valves to valve seats	Warmed	Idle running and free wheeling	Motorcycle operation is possible. Readjust clearance. Grind-in valves, when repairing.
Clutch cavity	Clear metallic clink	Clutch discs	Random	Clutch engaged	Operation can be continued. Inspect clutch when repairing engine/
<i>Zone where knocking is audible</i>	<i>Nature of knocks</i>	<i>Point (joint of parts) where knocking is possible</i>	<i>Thermal condition of engine</i>	<i>Engine running duty</i>	<i>Conclusion about fitness for further service</i>
Rear end of engine	Dull loud knocking which disappears once clutch is fully engaged	Flywheel to crankshaft		Idle running, clutch released	Discontinue motorcycle operation. Remove clutch, flywheel, check key joint, remount flywheel and fasten reliably

<i>Zone where knocking is audible</i>	<i>Nature of knocks</i>	<i>Point (joint of parts) where knocking is possible</i>	<i>Thermal condition of engine</i>	<i>Engine running duty</i>	<i>Conclusion about fitness for further service</i>
---------------------------------------	-------------------------	--	------------------------------------	----------------------------	---

Front top portion of engine	Frequent rolling metallic ratting squeal	Generator gear to camshaft gear		Variable	Having adjusted clearance between gears (by turning generator frame), continue to run the motorcycle normally
Front end of engine	Frequent metallic clink	Breather to front cover	Warmed	Idle running	Operation can be continued. Inspect breather, having removed timing cover at first chance.

Table 1.4-2. Troubleshooting

<i>Trouble</i>	<i>Symptoms and diagnosing</i>	<i>Cause</i>	<i>Remedy</i>
Engine fails to start.		Improper starting technique.	Proper starting procedure: Open petcock. Open enrichener (pull out) Switch on ignition. Put kill switch in "on" position (down). Stand on right foot on passenger foot pedal, kick start pedal with left foot. Once started, close enricheners.
Engine fails to start with storage battery intact.		1. Despite gasoline feed to carburetors, spark plug fails to ignite the fuel.	
	A) Undo spark plug connect body to "ground" and check for sparking between electrodes.	A) No gap between plug electrodes, carbon deposit or dirt in spark plugs, breakdown of insulator.	A) Change faulty spark plugs, or, depending on their condition, adjust gap or clean.
	B) Remove wire lug and check for proper sparking, connecting the lug to "ground" with the help of screwdriver and leaving a slight gap. If the spark appears, the plug is faulty. If there is no spark, no gap between distributor contracts.	B) No gap between the distributor contacts, oily or burnt contract.	B) Take off crankcase outer cover, adjust gap between contacts within 0.4 to 0.6 mm. Wipe and if need be, clean the contacts using fine file.
	C) If there is no spark when checking as described above, coil is faulty.	C) Faulty ignition coil.	C) Change faulty ignition coil.
		D) Break in low-voltage wiring.	D) Recover wiring.
		E) Ignition module defective.	E) Replace Ignition module.
		F) No gap between rotor and moving coil pickup.	F) Adjust gap equal to 0.2 - 0.3 mm.
		G) Contaminated contacts of plug connection.	G) Clean plug connection.
		2) Weak or no compression in engine:	
	A) When depressing the kickstarter, engine crankshaft turns freely with no sign of compression in engine.	A) No clearances in valve timing mechanism.	A) Adjust clearances properly.
	B) When depressing the kickstarter, engine crankshaft turns freely with no sign of compression stroke evident in all cylinders or in one of them.	B) Poor seating of valves due to carbon deposit or valve head burnt.	B) Repair engine, grind in or repair valves.
	C) Breather smoking.	C) Burnt or broken piston rings.	C) Repair engine. Clean or change piston rings.
	3. Engine crankshaft fails to turn when kickstarter is depressed.	3. Clutch slipping.	3. Adjust clutch controls. If clutch continues to slip, repair it (disassemble and inspection being necessary).
Engine missing/uneven one cylinder functioning.	1. Backfire in carburetor.	1. Lean mixture:	
		A) Erratic feed of gasoline to carburetor.	

<i>Trouble</i>	<i>Symptoms and diagnosing</i>	<i>Cause</i>	<i>Remedy</i>
		B) Carburetor jets or unbalanced channel of float chamber clogged.	
		2. Faulty spark plugs.	
	3. Pilot lamp is blinking.	3. Poor contact of battery terminals.	3. Restore proper contact of battery terminals.
		4. Mixture too rich due to flooding of float chamber.	
	A) Engine smokes badly, backfire in silencer, gasoline leaks from carburetor.	A) Float needle valve either dirty or leaky.	A) Clean the needle valve
	B) Engine smokes badly, backfire in silencer, gasoline leaks from carburetor.	B) Float is leaky.	B) Repair or replace faulty float.
	C) Engine smokes badly, backfire in silencer, gasoline leaks from carburetor.	C) Carburetor jet loose.	C) Set jet in place.
	8. Synchronized operation of cylinders disturbed.	8. Carburetor misadjusted.	8. Readjust throttle cables.
	9. Lack of compression, engine smoking, oil fouling the spark plugs.	9. Piston rings sticking or damaged.	9. Repair engine, clean or replace piston.
	10. Lack of compression.	10. Valves not seating properly due to carbon deposit.	10. Repair the engine, decarbonize and grind-in valves.
Engine Knocking	1. Knocks disappear, once ignition is delayed.	1. Advanced (early) ignition.	1. Retime engine.
	2. An expert mechanic determines the cause by listening to the running engine.	2. Piston pins, pistons, cylinders, crankpins, main bearings are worn.	2. Repair the engine.
Engine fails to develop full power, with throttle completely open, motorcycle fails to speed up.	1. Power increases once ignition is advanced.	1. Late ignition.	1. Retime engine.
	2. Lack of compression.	2. Valves not seating properly due to carbon deposit.	2. Repair the engine. Remove carbon and grind in valves.
	3. Lack of compression, engine smoking, spark plugs fouled with oil.	3. Piston rings sticking or damaged.	3. Repair the engine. Clean or change piston rings.
	4. Verify in repair shop.	4. Cylinders and pistons worn badly.	4. Repair engine. Recondition or replace cylinders and pistons in repair shop.
		5. Valve springs broken.	5. Change springs.
Engine overheats.	1. Engine fails to hold idle speed	1. Mixture too rich.	1. Clean float chamber of dirt, repair and adjust fuel system.

<i>Trouble</i>	<i>Symptoms and diagnosing</i>	<i>Cause</i>	<i>Remedy</i>
	A) Check whether gasoline flows out of float chamber (over-flooding of chamber).	A) Carburetor flooded due to poor fit of float valve.	A) Check condition of float valve and fuel level in float chamber.
		B) Clogged air cleaner.	B) Take off air cleaner and wash it.
	A) Air leakage at carburetor-to-cylinder head joints.	B) Backfire in carburetor.	B) Tighten nuts fastening the carburetor to cylinder head. Should air leakage continue, change gasket.
	3. Late timing:	3. Power increases, once ignition is advanced.	3. Retime engine.
High oil consumption.	1. Piston rings burnt or damaged.	1. Smoke emits from breather, engine smokes, spark plugs wet with oil.	1. Repair the engine. Change piston rings.
	2. Cylinder face or piston worn.	2. Same as in p. 1.	2. Repair the engine. Rebore cylinders or replace them (change simultaneously the piston and rings).
	3. Breather seat in gearbox cover worn.	3. Oil dripping from breather duct.	3. Repair the engine.
	4. Holes for draining oil from cylinder heads clogged.	4. Heavy carbon on spark plug electrodes, spark plugs oily and engine smokes.	4. Repair the engine.
Oil leaks under generator, under oil pump drive gear plug, at engine-to-gearbox joint and under timing box cover.	Breather jammed and its driving pin sheared.	With engine running, gases are blocked up in crankcase, heavy oil leaks through joints.	Repair the engine.
Squealing sound in breather.	Breather jammed in cover seat.	Breather fouled with aluminum deposit and scoring of locating surface in cover seat.	Repair the engine.
Clutch slips.	1. Clutch fails to engage fully due to misadjusted controls.	1. Check whether clutch lever play is sufficient.	1. Readjust controls by turning the adjusting screw so as to provide clutch lever tip play within 5 to 8 mm.
	2. Driven disks oily.	2. Check when dismantling or inspecting.	2. Dismantle the clutch. Wash disks in gasoline, eliminate cause of oil clogging.
Clutch fails to release fully (drags).	Misadjusted clutch gear (lever excessive play).	Check play of clutch lever located on handlebar.	Readjust clutch gear by turning the adjusting screw out, so as to provide full release of clutch and play of clutch lever within 5 to 8 mm.
When kickstarter is depressed, its pedal moves down, but engine crankshaft fails to turn.	1. Pawl, pawl pin or teeth or kickstarter ratchet are either worn or damaged. Clutch slips.	1. Having engaged gear, depress kickstarter. If motorcycle remains still - it is kickstarter that is faulty. If kickstarter is operated, but crankshaft fails to turn, then clutch is slipping.	1. Repair the gearbox. Change pawl or reverse it position. Change pawl pin. Change gear. Check proper adjustment of clutch controls. If need be, readjust it.
	2. Pawl spring is damaged or weak.		2. Repair the gearbox. Change pawl spring.
Kickstarter pedal fails to return to top position or returns slowly.	Kickstarter return spring weak or broken or springloaded pin sheared.	Check and make sure that kickstarter pedal returns unobstructed to top position.	Repair the gearbox. Change spring or pin.

<i>Trouble</i>	<i>Symptoms and diagnosing</i>	<i>Cause</i>	<i>Remedy</i>
1 st gear fails to be engaged by applying gear change foot pedal, but engages by means of reverse gear lever set on quadrant shaft splines. 4 th gear fails to be engaged by applying gear change foot pedal, but engages by means of reverse gear lever, set on quadrant shaft splines.	With gear change foot pedal depressed to the limit, pedal on quadrant shaft does not reach position which engages the required gear.	Upper screw of gear change foot pedal crank is misadjusted.	Readjust crank upper screw by turning out top adjusting screw.
Gear change foot pedal fails to return to initial position.	Gear shifting is faultless, but foot pedal fails to return after being depressed.	Return spring either weak or damaged.	Repair gearbox. Change return spring.
Gear disengages spontaneously with motorcycle running.		1. Gear change foot mechanism out of adjustment.	1. Readjust gear change foot mechanism.
		2. Gear shifting deranged due to wear of quadrant indexing flutes or due to bent gearshift quadrant.	2. Repair gearbox. Recover indexing flutes or change quadrant together with its shaft, straighten out bent quadrant.
		3. Teeth of gear shift sleeves worn out.	3. Repair the gearbox.
Reverse gear disengages spontaneously with motorcycle reverse running.		Gear tooth faces of reverse gear worn out.	Repair gearbox. Turn over the gear of reverse gear on bracket pin or replace starting gear.
Shifting of gears is difficult.		Seizing of gear shifting forks on shaft or in quadrant slots.	Repair the gearbox. Inspect and replace worn parts, if need be.
Noise in gearbox.		1. Gear teeth worn out.	1. Repair the gearbox. Change worn out gears.
		2. Clutch or main shaft bearings worn.	2. Ditto. Change worn out bearings.
Gear noise in final drive.		Backlash between teeth of gears too small or too great (0.1 to 0.3 mm being tolerated).	Repair the final drive. If need be, change it or its separate parts.
Overheating of final drive casing.		1. Wear or damage of parts.	1. Repair the final drive. Change the drive or worn parts.
		2. Play of brake pedal misadjusted. (Too tight)	2. Adjust play correctly. Leave approx. 1/16 - 1/8" free play at rear adjusting nut.
RUNNING GEAR			
Rattling in front fork.	1. Brake the front wheel and by pushing motorcycle to and fro by handlebar determine play in thrust bearings.	1. Play of steering column in thrust bearings.	1. Eliminate play by tightening bearings.
	2. Set motorcycle up on rear stand, raise front wheel. If excessive play is evident when moving legs up and down, this is a sign of front fork being damaged.	2. Fork leg tube bushings badly worn.	2. Repair the fork, check condition of parts, change bushings.
		3. Fork leg tips or springs turned out.	3. Undo binding nuts and check. Tighten tips or springs, if necessary.
Oil leaks out of front fork.	1. Oil stains on fork leg tips. Check condition of seal.	1. Front fork leg seals worn or damaged.	1. Change seals.

<i>Trouble</i>	<i>Symptoms and diagnosing</i>	<i>Cause</i>	<i>Remedy</i>
	2. Check tightening of nuts or seals.	2. Fork leg tip seals or their nuts loose.	2. Screw in nuts or seals.
Shock absorber squeaking	1. Cocking of upper barrel. Dismantle shock absorber and check condition of parts.	Rod unscrewed out of end piece.	1. Screw rod home.
	Ditto	2. Carrier spring broken.	2. Replace shock absorber.
Stiffness of suspension (bumpy)	Check condition of spring.	1. Sagging of carrier spring.	1. Replace shock absorber.
	2. Dismantle shock absorber, check for clogging of gauged ducts in piston and in lower valve.	2. Too much effort required for shock absorber to expand or contract.	2. Wash parts and prime shock absorber with fresh fluid.
Fork rotation is difficult		1. Steering damper bolt too tight.	1. Loosen bolt by turning it counter-clock-wise.
	2. Test fork rotation by changing the tightening of bearings.	2. Steering column bearings too tight.	2. Loosen bearings.
Steering damper loose (fails to be tightened up)	Steering damper friction washers oily or soiled.	Disassemble damper and examine washers.	Clean friction washers, check faces.
Wheel spokes broken	Examine and check tension of spokes by setting motorcycle on stand and turning the wheel, by pressing the wrench lightly to spokes, determine by sound if spokes are tightened uniformly or not.	Spokes loose or irregularly tightened.	Repair the wheels. Change broken spokes and readjust proper tension of all spokes.
Play of wheel on axle and wobble of wheel .	1. Gland nut loose and out-of-position.	1. Check by visual inspection.	1. Drive the gland nut home, then slacken by 1/8 of a revolution and safety it.
	2. Bushings or wheel roller bearings worn out.	2. Make sure that the cause of trouble is not as described in p.p. 1. Without removing the wheel, check for wobble.	2. Repair the wheel. Adjust tightening of bearings. If parts are replaced, pack them with grease.
	3. Wheel spoke tension disturbed due to long service.	3. With motorcycle set on stand, rotate the wheel. Check runout which should be within 1.5 mm on wheel rim.	3. Readjust proper tension of all wheel spokes.
Fluid leaks from shock absorber.	1. Fluid container nut loose.	1. Oil leaks from under nut.	1. Tighten fluid container nut.
	2. Shock absorber rod damaged or worn, scores, dents are evident.	2. Fluid leaks along rod.	2. Replace shock absorber.
	3. Seal damaged or worn.	3. Ditto.	3. Replace shock absorber.
Shock absorber piston rod travels freely (no effort) in the beginning of extension or compression stroke.		1. Lack of fluid.	1. Add fluid if necessary.
Rear wheel suspension swinging in excess, knocks audible when fully extended.		1. Lack of fluid.	1. Add fluid if necessary.
		2. Low fluid viscosity.	2. Prime with fluid of proper grade.
		3. Rebound valve leaky due to damage or clogging.	3. Replace the shock absorber.
		4. Rebound valve spring resilience is reduced.	4. Replace the shock absorber.
		5. Piston relief valve leaky.	5. Replace shock absorber.
<i>Trouble</i>	<i>Symptoms and diagnosing</i>	<i>Cause</i>	<i>Remedy</i>
	6. Piston broken or deep scores	6. Fluid leaks along rod.	

	are evident.		
Shock absorber is knocking.	1. Deteriorated rubber bushings or end fastening silent blocks.	1. Check fastening and conditions of parts.	1. Change worn parts.
	2. Bolts fastening the shock absorber are loose.	2. Check fastening bolts.	2. Tighten up bolts.
CONTROLS			
Carburetor throttle control grip is difficult to twist.		1. Adjusting screw too tight.	1. Loosen and lock adjusting screw.
	2. Lubricate it and see if this will help. Pull out cable armours from twistgrip housing and by twisting the grip and lowering cable armour determine cause of slide seizing.	Slide is seized.	2. Lubricate the slide. If twisting is still difficult, remove twistgrip, examine it and lubricate.
Once hand is removed from twistgrip, it turns spontaneously.	1. Trouble is remedied when adjusting screw is tightened .	Adjusting screw loose.	1. Readjust and lock screw.
	2. Tightening of adjusting screw does not remedy trouble.	Spring that brakes twistgrip is broken.	2. Repair the twistgrip. Remove twistgrip and replace spring.
Rear wheel or sidecar wheel fails to be braked.	1. Readjust and try out rear brake action.	Rear brake pedal play misadjusted.	1. Reduce play of brake pedal by turning wing nut on brake link clockwise and simultaneously checking wheel rotation. Leave a slight play of pedal (1/16 1/8 in) for heat expansion. After adjustment, check brake action.
	2. After readjustment, as instructed in p. 1, brake shoes are slipping.	Brake shoe linings of rear wheel brake oily or soiled.	2. Remove wheel, wash brake shoes in gasoline and wipe dry. If oiling persists, check quantity and quality of oil in final drive and condition of seal.
	3. After readjustment, as instructed in p. 1m brake shoes are slipping.	Brake shoe linings worn.	3. Using adjusting bolts, readjust clearance of brake shoes.
Front wheel fails to be braked.	1. Same as for rear wheel.	1. Same as for rear wheel.	1. Reduce play of brake lever by turning the adjusting screw in brake cover, simultaneously check rotation of wheel. Leave a slight play for heat expansion. If there is no reserve of thread on adjusting screw, remove brake lever and turn it to new angle on brake cam splines.
Brakes overheat.	1. Set up motorcycle on the stand, check rotation of wheels without depressing pedal and lever.	No play in foot brake pedal or front brake lever, resulting in brake shoes being constantly pressed to drum.	1. Set motorcycle on stand. Turn wing nut of brake pull rod counter clock-wise until rear wheel revolves freely. By turning in adjusting screw on brake drum cover of front wheel obtain free rotation of wheel. After adjusting, check brake performance.

<i>Trouble</i>	<i>Symptoms and diagnosing</i>	<i>Cause</i>	<i>Remedy</i>
	2. Cam is stuck in position which corresponds to braking action and fails to return into initial position.	2. Brake cam pin seized.	2. Lubricate cam. If trouble persists, take wheel off, remove brake cam, wash or reface it, if necessary.

	3. Cam is stuck in position corresponding to maximum separation of shoes and fails to return into initial position.	3. Brake cam seized due to large turn angle, caused by worn linings of brake shoes.	3. Using adjusting bolts readjust clearance of brake shoes.
ELECTRICAL EQUIPMENT			
With ignition lock key in "ON" position, pilot lamp fails to light up.	1. Ground switch "Off."	3. Switch is not grounded	3. Ensure that the ignition switch is properly grounded.
	2. Check condition of bulb.	2. Lamp is blown.	2. Change faulty bulb.
	3. Check if safety fuse is intact.	3. Safety fuse of lighting system is blown.	3. Change faulty fuse.
	4. Check, if contacts are clean and tightened. Check, if wiring is intact, especially wire lugs at contact terminals of safety fuse block and ignition lock.	4. No contact: A) on battery terminals B) on terminal of ground switch C) on alternator + terminal D) on terminals "2" and "3" of master switch. E) on "ground" terminal of engine. F) on safety fuse terminals of ignition system.	4. If necessary, clean contact surfaces of wire lugs, restore condition of wiring, tighten the terminals.
With ignition lock key in "ON" position, pilot lamp glows, but there is no sound when horn button is depressed.	Check that contacts are clean and tightened. Check that wiring is intact, especially, wire terminals of light switch.	1. No contact: A) on terminal of horn wire lug B) on terminal of wires in plug and socket connector C) on terminal in light turn key contact D) on "ground" through switch body and handlebar.	If necessary, clean contact surfaces of wire lug, recondition wiring, tighten up terminals.
		2. Break in wires of some circuit link from horn to lighting switch.	2. Check and repair open circuit.
With ignition lock key in "ON" position, pilot lamp glows. When horn button is pressed, horn sounds. Engine fails to start running. Weak sparking in spark plugs.	1. Check that wiring is in good order in these links of circuit.	1. No contact.	1. Clean contact surfaces of wire lugs, recondition wire lugs, recondition wiring, tighten up terminals with screws for better contact.
		A) no contact on terminals of red wires from ignition coil.	ditto
		B) no contact on wire terminal of ignition coil from high-voltage end.	ditto
		C) no contact on breaker terminal.	ditto
		D) no contact on wire terminals of ignition coil from high-voltage end.	ditto
		E) no contact on plug tip screw with high-voltage wire core.	ditto
With parking light "On" sidecar side lamps fail to glow.	1. If wires are connected outside the coupling, lamps start glowing.	1. Poor contact in coupling block.	1. Repair connection in coupling.

<i>Trouble</i>	<i>Symptoms and diagnosing</i>	<i>Cause</i>	<i>Remedy</i>
	2. If wires are connected outside the coupling block, lamps fail to glow.	2. Wire break in circuit from fuse block terminal to coupling block or behind it.	2. Find out and remedy break.
With light "On", either front or rear lamp glows.	1. Take out lamp bulb that is not glowing, check it by examining its filament or directly from storage battery.	1. One of lamp bulbs is blown.	1. Change faulty lamp bulb
	2. If wires are connected outside the coupling block, lamps fail to glow.	2. Break in circuit from fuse block terminal to coupling block or behind it.	2. Find out and remedy break.
While engine is running at variable speeds, pilot lamp glows steadily.		Worn alternator brushes	Replace brush assembly.
		2. Some internal fault of regulator.	2. Replace voltage regulator assembly.
		3. Some internal fault of alternator.	4 Check and replace alternator.
With motorcycle running, pilot lamp is blinking.		Poor contact on terminals of alternator.	Clean and tighten wire lugs and terminals.
Direction indicators fail to light up although their switch is cut in.	Check fuse and direction relay.	1. Fuse blown in fuse block.	1. Change faulty fuse.
		2. Some Internal fault of direction relay.	2. Change direction relay.
With direction indicator switched on, not all direction indicators glow.	Check lamp bulb contacts on wire terminals and indicator housing to "ground" contact.	1. Direction indicator lamp bulb blown.	1. Change lamp bulbs.
		2. No contact in wire terminals.	2. Restore contacts.
		3. No contact between indicator housing and "ground."	3. Restore contact.

1.5 General Dismantling And Repair Techniques

When it has been determined that a component needs repair, try to remove the minimum number of parts and assemblies necessary to determine the specific problem and solve it. Certain components can be partially dismantled while still on the motorcycle. For example, the cylinder heads can be removed without taking off the cylinders. Most URAL[®] components can be removed separately and repaired by standard machine shop techniques and replacement of individual parts. Removal/installation procedures are included in each section.

When removing components such as the right head or cylinder, time may be saved by first removing the sidecar to allow easier access to the right side of the motorcycle.

Before beginning any dismantling, take care to clean the surrounding parts to protect the friction parts of dismantled units from contamination. As parts are disassembled, clean off grease, carbon, remnants of bakelite varnish, etc., and wash them properly before attempting to check their condition by visual inspection and measurements.

To help determine the serviceability of parts and assemblies, critical dimensions and tolerances are listed in each section, as well as suggestions for visual inspection and measurement. When repairing components ("assembly units"), it is important to carefully check critical dimensions, which should fall within the values set by the factory as listed in Table 1.5-1. The maximum tolerated limits of wear and clearances between the principal wear parts of the engine are given in Table 1.5-2. These tables will help determine fitness of parts and components for further service.

Most URAL[®] engine components, such as cylinders and cylinder heads can be repaired by local machine shops using standard practices. Other components, such as the crankshaft, require special fixtures and techniques. Critical parts, such as timing gears and final drive gears should be replaced as matched sets only. Connecting rods and piston pins are matched by size groupings, indicated by color coding.

Unless specifically noted, components may be disassembled and reassembled at ambient temperature. Where parts must be heated, the procedures and temperatures are described. Measurements and tolerances will, where possible, be listed in inch dimensions, (followed by the metric equivalent in parenthesis).

Torque values are listed in foot-pounds, (followed by the metric equivalent in Newton-meters). Actual torque on fasteners depends upon condition and lubrication of the fastener threads. Listed torque values are for dry threads in good condition (easy finger rotation possible) If fasteners are lubricated with oil, torque wrench values should be reduced by approximately 10%. Conversion tables are located in Section 1.

Standard automotive and aviation gasket compounds, lubricants, and sealants may be used on URAL® components in lieu of the specified Russian products, unless otherwise noted.

Stripped threads in housings may be repaired with metric coil-type thread inserts. Metric fasteners are readily available in the USA at hardware and auto parts stores. Bolts, nuts, and studs of grade 8 or higher may be substituted for the equivalent URAL® fasteners. Other substitute parts are listed in Section 10.3.

Care of Motorcycle Paint

For washing the motorcycle, use a weak stream of cold or warmed water. Do not remove dust and mud by rubbing the surface with a dry cloth, as sand particles will scratch the surface and the paint will rapidly lose its brilliance. While washing, do not use soda solution, kerosene or mineral oils. If the surface is stained with mineral oil, degrease by wiping with a rag. If after removal of mud and dust with a jet of water, some dirt is left on the surface, remove it with the help of a sponge, a soft hair brush or a flannel rag and water, but do not allow separate water drops to dry out on the surface. Finally, polish the painted surfaces with a dry soft flannel.

The painted surfaces of the motorcycle feature natural gloss. If some dull spots appear, remedy them by polishing as follows. Take a well mixed solution of wax polishing compound and having washed the dull spots thoroughly, smear a thin film of the compound over the surface with a polishing cloth. Rub the polishing compound with circular motions. After 3-5 minutes of drying, wipe the surface with a clean dry piece of polishing cloth until a luster appears.

To repair painted areas, each motorcycle is furnished with a bottle of touch-up paint. Nitroenamels dissolve or dilute with acetone and dry out readily when exposed to air at typical shop temperatures.

For repairing paint, proceed as follows:

- clean the surface with solvent or turpentine to remove any wax
- wet sand the damaged spot with waterproof sandpaper of 250 to 280 grit
- paint the area with primer, and spot putty as needed
- wet sand again and dry thoroughly
- thin the touch-up paint with turpentine or acetone and apply

Table 1.5-1 Critical Dimension of Engine Components

* NOTE: ALL DIMMENSIONS LISTED ARE GIVEN IN MM

Part No. & name (shaft)	Rated size & tolerance	No. name of mating member (hole)	Rated size & allow.	Tolerated limits				Remarks
				Positive Allow.		Negative Allow.		
				min.	max.	min.	max.	
6601237 Piston (skirt diameter)	-0.060 78 +0.090	6101031	+0.030 78					Out of round and taper dia. 78 +0.030 within 0.015.
	C 77.930-77.940 B 77.920-77.930 A 77.910-77.920		C 78.020-78.030 B 78.010-78.020 A 78.000-78.010	0.080 0.080 0.080	0.100 0.100 0.100			Group index is stamped on piston head and on top end face of cylinder.
6601238-01 Piston pin (outer diameter)	-0.010 21	6601237	-0.007 21 -0.017					Out of round and taper of pin within 0.0025.
	White 21.000-20.9975 Black 20.9975-20.9550 Red 20.9950-20.9925 Green 20.9925-20.9900		White 20.9930-20.9905 Black 20.9905-20.9880 Red 20.9880-20.9855 Green 20.9855-20.9830			0.0045 0.0045 0.0045 0.0045	0.0095 0.0095 0.0095 0.0095	Color index of group is marked on bore of one of pin end faces and on one of bosses inside the piston.
6601238-01 Piston pin (outer diameter)	-0.010 21	660127 Connecting rod assy (hole in connecting rod small end)	+0.0095 21 -0.0005					Out of round and taper in connecting rod small end within 0.003.
	White 21.0000-20.9975 Black 20.9975-20.9950 Red 20.9950-20.9925 Green 20.9925-20.9900		White 21.0095-20.0070 Black 20.0070-20.0045 Red 20.0045-21.0020 Green 20.0020-20.9995	0.007 0.007 0.007 0.007	0.012 0.012 0.012 0.012			Color indexes are marked on bore of one of pin end faces and on connecting rod stem at small end.

Part No. & name (shaft)	Rated size & tolerance	No. name of mating member (hole)	Rated size & allow.	Tolerated limits				Remarks
				Positive Allow.		Negative Allow.		
				min.	max.	min.	max.	
6601022-A* Compression ring (ring height)	-0.010 2.5 0.022	6601237 Piston (groove depth)	+0.055 2.5 -0.030	0.040	0.077			
6601022-A* Oil control piston ring.	5 -0.015	6601237 Piston (groove depth)	+0.050 5 +0.025	0.025	0.065			
7201234-A Connecting rod small end bushing	+0.145 23.5 +0.100	6601233 Connecting rod	+0.023 23.5			0.077	0.145	
6601203 Crankpin	+0.010 40 -0.006	6601201 Crank front journal	-0.13 40 -0.16			0.124	0.170	
		6601211 Crank rear journal						
6601203 Crankpin	+0.010 40 -0.006	6601202 Crank cheek	-0.090 40 -0.120			0.084	0.130	
6601233 Connecting rod width of big end)	17.2 -0.035	6601026 Crank mechanism assy (size, between cheek and journal)	+0.105 17.4	0.200	0.340			
6601208 Cage width	17 -0.17	6601233 Connecting rod (width of big end)	17.2 -0.035	0.165	0.370			
6601207 Cage	49.7 -0.100	6601027 Connecting rod, assy.	+0.018 50	0.300	0.418			
6601203 Crankpin	+0.010 40 -0.006	6601208 Cage	+0.17 42	1.990	2.176			
6601201 Crank front journal	35 ± 0.08	207 Ball bearing	+0.003 35 -0.015		0.020 0.083		0.015 0.095	
6601211 Crank rear journal	35 ± 0.08	207 Ball bearing	+0.003 35 -0.015		0.020		0.015	Out of round and taper within 0.01
6601201 Crank front journal	+0.039 30 +0.025	7201229 Drive timing gear	+0.023 30			0.002	0.039	
6201136 Front bearing housing	+0.040 77 +0.020	Z101-01008 Engine crankcase	+0.030 77		0.010		0.040	
6601141 Rear bearing housing	150 ± 0.014	Z101-01008 Engine crankcase	+0.041 150 -0.022		0.055		0.036	
207 Ball bearing	+0.004 72 -0.017	720141-b Rear bearing housing	72 -0.023		0.017		0.034	

* Sold as a complete set.

Part No. & name (shaft)	Rated size & tolerance	No. name of mating member (hole)	Rated size & allow.	Tolerated limits			
				Positive Allow.		Negative Allow.	
				min.	max.	min.	max.
207 Ball bearing	+0.004 72 -0.017	6201136 Front bearing housing	+0.008 72 -0.023		0.025		0.027
6201401-01 Camshaft	+0.062 22 +0.039	6201424 Oil pump drive camshaft gear	+0.023 22			0.016	0.062
6201401-01 Camshaft	+0.062 22 +0.039	7201406-01 Camshaft gear	+0.023 22			0.016	0.062
6201401-01 Camshaft	22 -0.014	7201107 Camshaft bushing	+0.105 22 +0.080	0.080	0.119		
7201107 Camshaft bushing	+0.100 26 +0.055	Z101-01008 engine crankcase	+0.023 26			0.032	0.100
6201046 Tappet	-0.016 14 -0.033	6201409-01 Tappet guide	+0.019 14	0.016	0.052		
Z101-01437 Rockshaft	-0.030 15 -0.055	Z101-01057 Left-hand rocking arm	+0.027 15	0.030	0.082		
Z101-01437 Rockshaft	-0.030 15 -0.055	Z101-01058 Right-hand rocking arm	+0.027 15	0.030	0.082		
6201507 Valve seat	+0.110 38.2 +0.060	Z101-01502/503 Cylinder head	+0.050 38	0.210	0.310		
6601524 Intake valve seat	+0.110 41.2 +0.060	Z101-1502/503 Cylinder head	+0.050 41			0.0210	0.310
6201505 Valve guide	+0.080 14 +0.063	Z101-01502/503 cylinder head	+0.035 14				
6201415-b Exhaust valve	-0.035 8 -0.052	6201505 Valve guide	+0.030 8	0.035	0.082	0.028	0.080
6601416 Intake valve	-0.035 8 -0.052	620150 Valve guide	+0.030 8	0.035	0.082		
7201225 Clutch pin	+0.080 12 +0.045	7201223 Flywheel	+0.035 12			0.010	0.080
7201225 Clutch pin	+0.080 12 +0.045	6203117 Clutch intermediate plate	+0.035 12.5	0.420	0.490		
7201225 Clutch pin	+0.080 12 +0.045	7203121-A	+0.035 12.5	0.420	0.490		

Table 1.5-2 Maximum tolerated limits of Wear and Clearances Between Principal mating Members of the Engine, *IN MILIMETERS*.

<i>Name of parts and mated pairs of parts</i>	<i>Maximum Tolerances</i>			<i>Measuring point and method</i>
	<i>Wear on diameter</i>	<i>Out-of-round and taper</i>	<i>Diameter clearance</i>	
Crankpin to rollers to connecting rod big end			0.100	
Crankpin	0.050			
Connecting rod big end	0.050			
Cylinder	0.150	Out-of-round 0.070		In five points (refer to “Repairing the Crank Mechanism” of subsection 2).
Cylinder to piston			0.200	Measure piston in plane, square to pin axis at point 5 mm from the piston lower edge.
Piston pin	0.015			
Hole in piston to fit pin	0.020			
Piston to piston pin			0.010	
Connecting rod small end bush	0.025			
Piston pin to connecting rod small end bush			0.030	
Compression ring (height)	0.050			
Piston groove to piston ring			0.150 (by depth)	
Piston groove to oil control ring			0.150 (by depth)	
Valve stem	0.120			
Valve guiding bush	0.150			
Valve stem to guiding bush			0.250	
Rockshaft	0.070			
Rocking arm (aperture)	0.070			
Rockshaft to rocking arm			0.120	
Tappet	0.050			
Tappet guide	0.050			
Tappet to tappet guide			0.100	

CHASSIS AND RUNNING GEAR

2.1 Description and General Specifications

The chassis and running gear of the motorcycle is comprised of the motorcycle and the sidecar frames, operating controls, wheel suspension, brakes, wheel assemblies and tires, fenders, bench seat, and windshield (if equipped).

The frame is the principal bearing element of the motorcycle to which all the units and assemblies of the motorcycle are attached. The motorcycle is furnished with a double loop frame of welded construction. For the design features and principal members of the motorcycle and the sidecar frames refer to Fig. 2.1-1.

The frame of the solo motorcycle differs from the sidecar motorcycle, by the absence of the sidecar fasteners and the parking brake mechanism, addition of a sidestand and brackets for securing the solo tire pump.

The sidecar frame is coupled to the motorcycle frame by ball pins and collet clamps (10) and (17) and two adjustable frame legs (9) and (15). The sidecar frame is large-diameter welded steel tubing, and incorporates pads on the rear member for rubber body support cushions. The sidecar swing arm is connected to its frame by rubber "silent block" bushings. The swing arm is suspended by a spring loaded hydraulic shock absorber.

RUNNING GEAR	TOURIST / PATROL	DECO CLASSIC & SOLO
Frame	Tubular welded	
<i>Rear wheel suspension</i>	<i>Swing arm with hydraulic spring shock absorbers</i>	<i>Sidecar: same as -40 Solo: Lower spring rate</i>
Front fork	Leading link	Telescopic spring
<i>Sidecar</i>	<i>Cushioned body (on rubber cushions) and wheel on long-lever suspension with hydraulic spring shock absorber</i>	<i>Sidecar attached same as previous. Solo: N/A</i>
Brakes	Shoe-type with mechanical drive on front, rear and sidecar wheels, front wheel has dual cams.	
<i>Tires</i>	<i>4" X 19" Front & Side: 22 psi cold Rear: 36 psi cold</i>	<i>3.5" X 18" Solo: Front 25 psi cold Rear: 32 psi cold -10's: Front & side: 22 psi cold Rear: 36 psi cold</i>

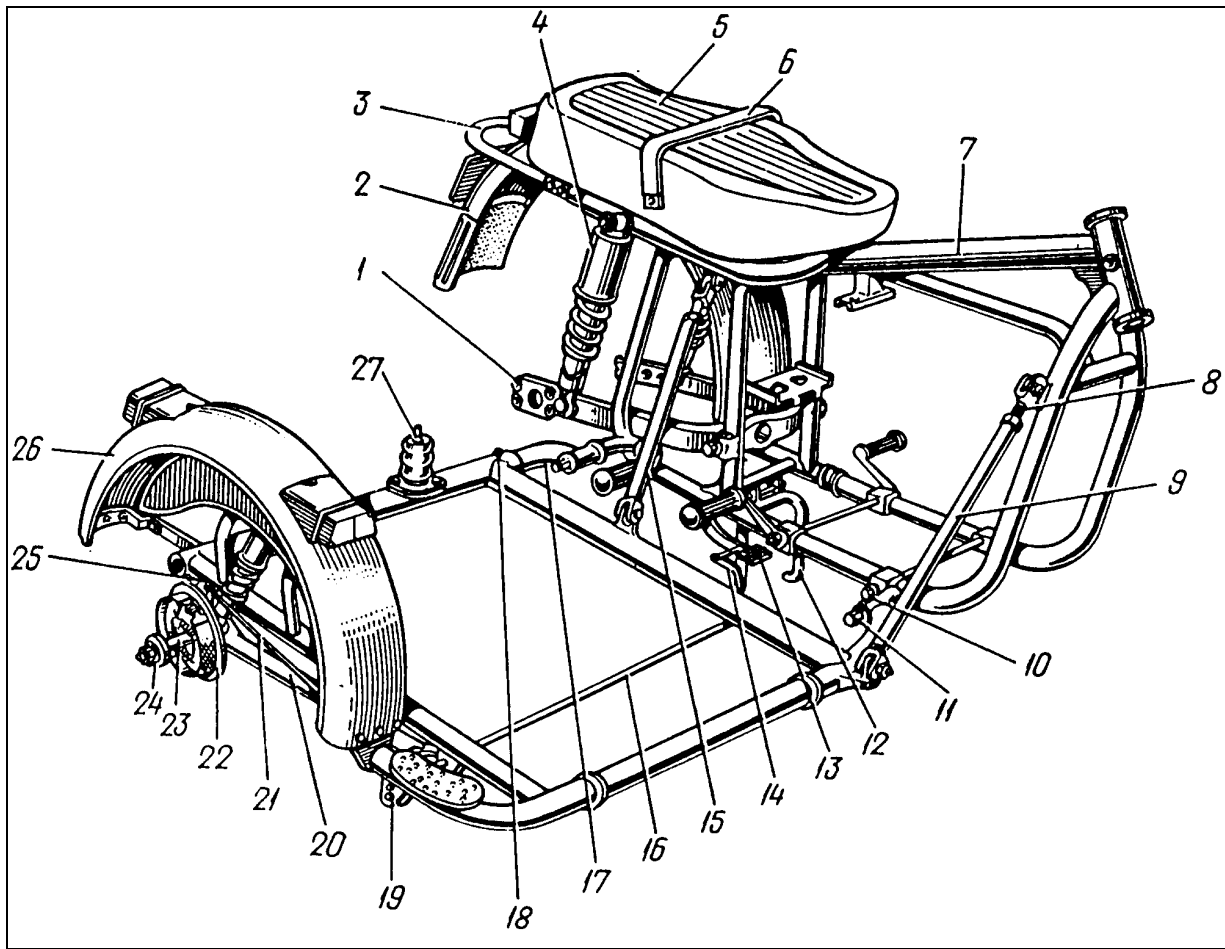

Figure 2.1-1 Motorcycle and Sidecar Frames

- | | | |
|---|---|--|
| <i>1 - Rear suspension swinging arm</i> | <i>10 - Collet clamp</i> | <i>20 - Lever</i> |
| <i>2 - Rear mud shield</i> | <i>11 - Collet clamp screw</i> | <i>21 - Brake tie rod</i> |
| <i>3 - Rear grab bar</i> | <i>12 - Motorcycle stand</i> | <i>22 - Brake drum cover</i> |
| <i>4 - Spring-loaded hydraulic shock absorber</i> | <i>13 - Brake pedal</i> | <i>23 - Sidecar wheel axle</i> |
| <i>5 - Seat (Saddle or Tractor)</i> | <i>14 - Sidecar wheel brake lever</i> | <i>24 - Protective hood</i> |
| <i>6 - Strap</i> | <i>15 - Sidecar frame leg</i> | <i>25 - Tie rod nut</i> |
| <i>7 - Motorcycle Frame</i> | <i>16 - Sidecar wheel brake rod</i> | <i>26 - Sidecar fender</i> |
| <i>8 - Leg adjusting fork</i> | <i>17 - Rear collet clamp bracket</i> | <i>27 - Rubber member of body suspension</i> |
| <i>9 - Sidecar frame leg</i> | <i>18 - Rear bracket fastening bolt</i> | |
| | <i>19 - Lever pins</i> | |

2.2 Operating Controls

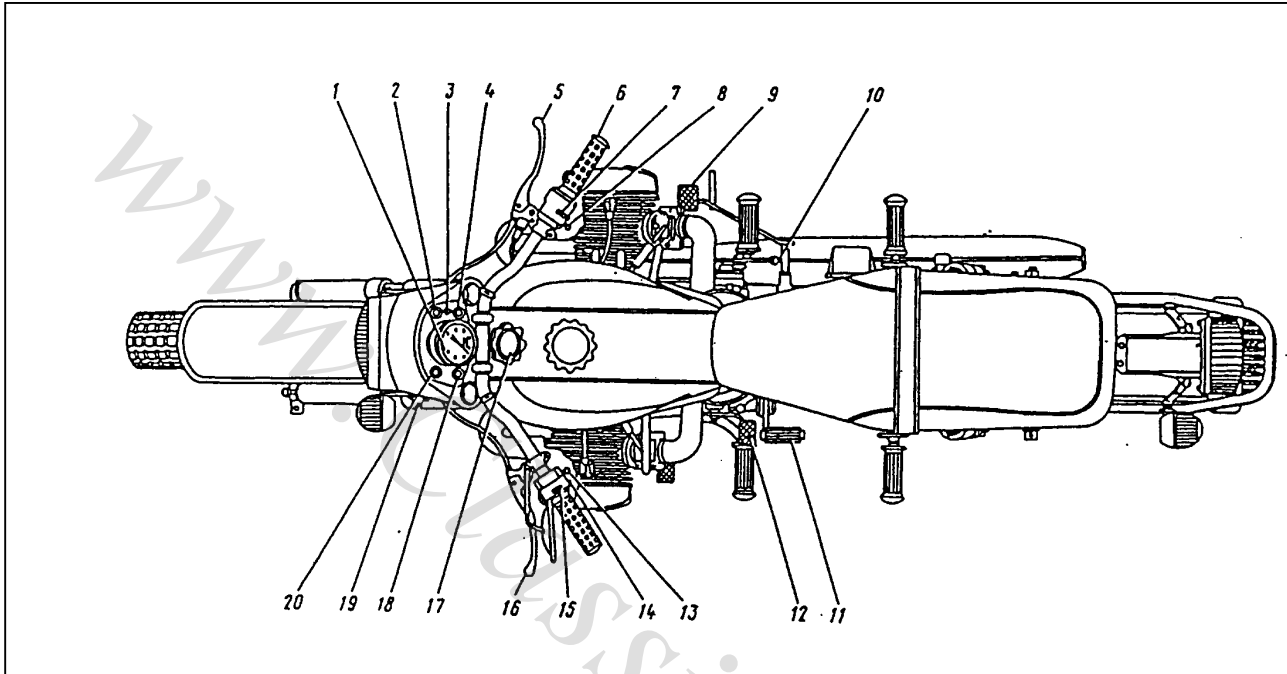

Figure 2.2-1. Controls and Instrumentations

- | | |
|--|--|
| 1 - Speedometer | 12 - Gear shift (foot) pedal |
| 2 - Turn indicator pilot lamp | 13 - Turn indicator switch |
| 3 - Trip odometer reset knob | 14 - Horn push-button |
| 4 - Neutral and reverse gear engagement pilot lamp | 15 - "High-low" beam switch |
| 5 - Front brake control lever | 16 - Clutch control lever |
| 6 - Carburetor throttle control twist grip | 17 - Steering damper tightening bolt |
| 7 - Ignition kill switch | 18 - High-beam indicator light |
| 8 - Electric start button (optional) | 19 - Ignition lock |
| 9 - Rear brake pedal and sidecar wheel brake | 20 - Alternator indicator light |
| 10 - Reverse gear lever | 21 - Master battery switch
(under seat) Not pictured. |
| 11 - Kick start lever | |

The handle bar is mounted on the front fork through two brackets secured on the cross-piece of the front fork. The handle bar is adjustable in the brackets.

The carburetor throttle control twist grip (6) is linked to the carburetor throttles by flexible control cables. The clutch lever is linked to the clutch release arm by a cable. When the throttle control twist grip is activated (turn the twist grip counterclockwise), the flow of fuel to the carburetors will be increased, which will increase engine speed (RPM).

Clutch lever (16). When the clutch lever is squeezed, the clutch is released - the engine is disengaged from the gearbox. When the lever is released, the clutch is engaged and the engine is connected to the gearbox. The clutch allows manual selection of gears in ascending or descending sequence.

WARNING: Both the clutch and front brake levers are capable of contacting the handlebar grip, depending on adjustment. Motorcycle operator should be cautioned to avoid placing fingers between lever and grip when operating the control, to avoid accidental pinching of fingers.

WARNING: Before starting engine, always shift transmission to neutral to prevent accidental movement which could cause damage to motorcycle and personal injury.

Front brake control lever (5). The front brake lever is connected by the cable to the lever mounted on the front brake drum cover. When the lever is squeezed, the front wheel brake is actuated. The front brake should be used together with rear brake. At the base of the brake lever the stop signal switch is set. When the brake lever is pressed, the stop signal lamps are switched on.

Kick lever (11). The kick lever is designed to start the engine. On pressing the lever the crankshaft of the engine is actuated through the accelerating gear. The lever is returned to its initial position by the spring inside the gearbox.

The Gear shift foot pedal (12) (Also see Fig. 4.9-5, item 1) is a two arm type. When the front arm is pressed, shifting from high to lower gears takes place. When the rear arm is pressed, shifting from low to higher gears takes place. Since the heel-toe shift lever is short-coupled, you will find it easier to shift up if you rotate the heel of your left foot in towards the rear arm before stepping on it with your heel. The neutral position is fixed between the I and II gears.

IMPORTANT! The green pilot lamp glows when the transmission is in neutral and when the reverse gear is engaged (see "Start-Up of Engine").

Reverse gear engagement lever (10). Press forward for neutral and/or forward running and back for reverse.

CAUTION: The reverse gear may be engaged only after the motorcycle is completely stopped.

To engage the reverse gear, shift into neutral (or low), then push the reverse lever (10). To disengage the gear shift mechanism, press lever (10) up (forward) to the limit; then the gear shift mechanism is reset to the neutral position. Now you may shift into first gear. If desired, neutral may be selected by shifting into reverse and back to forward again, when the I gear is engaged, and then moving the reverse gear lever forward.

Rear brake pedal (9) applies both motorcycles rear wheel and sidecar wheel brakes simultaneously.

WARNING: An improperly adjusted rear brake pedal could contact the exhaust system and interfere with proper rear brake operation. An improperly adjusted rear brake push rod could cause dragging brakes or interference between brake pedal and exhaust system.

The **ignition lock (19)** has three fixed positions of the key. The position and switching diagram of the ignition lock are given in Fig. 2.2-2.

Running position (I) Voltage is supplied to the ignition (via the Cutoff Switch), horn, stop signal switches, neutral pilot lamp, turn indicator interrupter, and head and tail lamps.

NOTE: (II position is not to be used for US import models due to DOT regulations but the switch should not be left in the II position, which could discharge the battery. Always turn the key to the O position to remove the key).

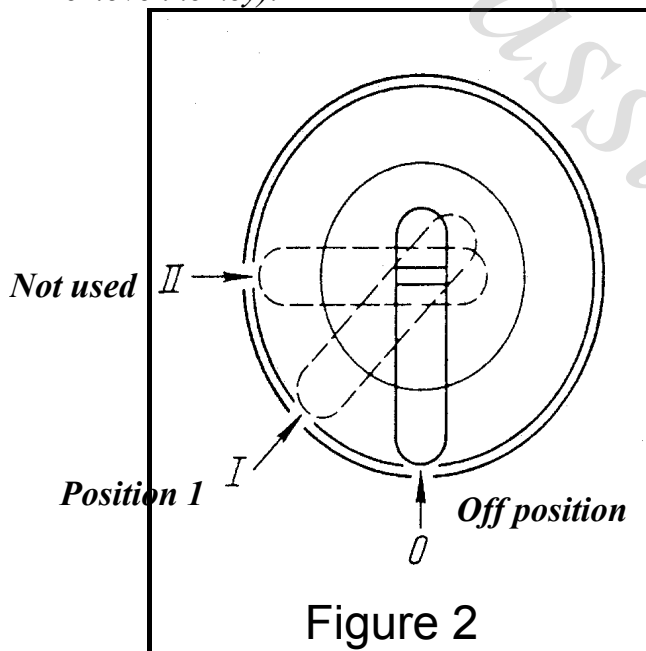

The Speedometer (1) on the dash board has both a trip and total odometer. The trip odometer is reset to zero by rotating push-button (3) counter-clockwise. Note that the odometer reads in km rather than miles, although the speedometer reads in mph as well as km. The indicator lamps are also mounted on the instrument board:

- (2) -- turn indicator pilot lamp, orange;
- (4) -- gearbox neutral and reverse gear engagement, green
- (18) -- head lamp high beam indicator, dark blue;
- (20) -- alternator indicator lamp, red (discharging battery).

The **engine cutoff switch (7)** is on the twist grip housing. There are two positions: ignition off, and ignition on (Run).

Low and high beam light switch (15), turn indicator switch (13) and horn push-button (14) are combined in one unit on the left-hand grip housing.

The steering damper helps absorb sudden lateral oscillations of the front end. Turning **tightening bolt (17)** clockwise increases friction to damp steering oscillations.

WARNING: Do not tighten the damper to the point where the steering becomes stiff. Doing so will adversely affect handling qualities. This is particularly critical for the Solo model.

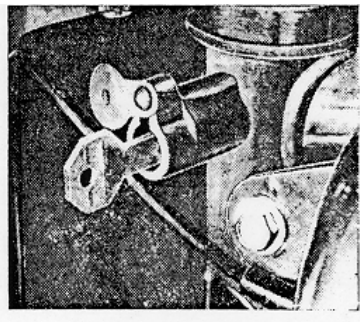

Fork lock. The motorcycle is provided with a fork lock with an individual key. The lock is mounted on the left-hand side of the head tube of the motorcycle frame (Fig. 2.2-3). To lock the motorcycle, turn the handle bar fully to the right, insert the key, turn it to the left while pressing in slightly, then release and remove the key. To unlock, insert the key, turn it to the left, pull gently, release and then remove the key.

Fig. 2.2-3 Fork Lock

NOTE: The fork lock tends to be stubborn, and owners may find it more trouble and less advantage to use the fork lock than use some alternative means of security such as a cable and padlock. If the fork lock is used, it is typically necessary to wiggle the fork back and forth to find a position where the lock will function properly.

Control Cable Adjustment and Maintenance

The control cables are adjusted by screw adjustments at the cable ends.

With the control levers released:

- For the clutch: a play at the clutch lever end should be equal to 5 - 8 mm / 0.2 - 0.3 in.

- For the brakes: a 0.3 - 0.7 mm / 0.012 - 0.028 in gap between the brake shoes and the brake drums; for this purpose a 5 - 8 mm / 0.2 - 0.3 in play of the front brake control lever and a play of the rear brake pedal equal to about 25 - 30 mm / 1 in of the full stroke of the pedal are required;
- For the carburetors: carburetor throttles synchronized

With the control levers (handles) fully depressed:

- For the clutch: complete disengagement of the engine from the transmission; noiseless shifting of gears means good adjustment of the clutch cable.
- For the carburetors: lift of throttles to the maximum and equal height;
- For the brakes: effective braking of the motorcycle before levers reach limits.

Removing and Reinstalling the Handlebar With Control Cables and Switches

To remove the handlebar with all the control cables and switches:

- remove the fuel tank
- disconnect the throttle cables from the carburetors
- disconnect front brake cable from brake drum cover
- unplug the electrical connectors
- undo the nuts fastening the handlebar brackets to the fork cross-piece and remove the handlebar.

Reverse the sequence of the operations when reinstalling the handlebar.

CAUTION: Do not attempt to over tighten any of the small screws fastening switches or levers to the handlebar.

The tightening torque of the handlebar bracket nuts is 30 foot/pounds / 41 Nm.

Dismantling and Reassembling the Throttle Control Twist grip

To dismantle the twist grip:

- undo the screws and remove the carburetor cable tips
- compress the throttle springs and remove the cable tips
- undo the screws fastening the halves of the switch body and remove the upper part
- tilt the throttle control twist grip and remove the cable tips out of the slider
- unlock the adjusting screw and loosen it one or two turns
- slacken off the screw fastening the switch body and remove the throttle control twistgrip with chain and a slider

Clean and inspect the parts, especially the cable ends. When reassembling, lubricate the moving parts with chassis grease.

Reassemble the twist grip in the following order:

- set the throttle control twist grip on the handlebar and in the lower half of the body, having preliminarily lubricated the twist grip tube rotation
- set the cable tips into the twist grip slider and lubricate the points of the twist grip tube rotation
- set and screw up the upper half of the body
- secure the screw fastening the switch body
- set the cable tips into the twist grip slider, reinstall the throttles and secure the covers
- adjust the twist grip rotation with an adjusting screw and lock it with a nut

Repairing the clutch and brake control levers and cables

Check the condition of control cables at every service of the motorcycle. Even if a single wire is found broken or the cable armour is damaged (seizing, extension, etc.) replace the cable. If the end ball of the control cable is disturbed (the tip slips off the cable), solder a new tip on, spreading the cable end wires apart prior to soldering to ensure the wires jam into the hole. The handlebar control lever pivots should be tightened only far enough to ensure their free pivoting without excessive play.

When inspecting the handlebar, pay special attention to the brackets which fasten it to the fork cross-piece and check the bracket end for cracks. Replace the brackets, if defects are revealed. To remove the brackets from the tube, unscrew the nut or the bolt fastening the handlebar tube to the brackets, insert a wedge (such as a screwdriver tip) into the slot and spread the bracket slot to permit taking the bracket from the tube.

Speedometer

The speedometer scale is illuminated with two lamps. The speedometer is driven by the main shaft of the gearbox via a flexible cable.

Every 10,000 km , add five or six drops of oil into the union butt end to lubricate the speedometer axle. Lubricate the flexible cable with speedometer cable lubricant.

2.3 Front Fork and Suspension

Two different types of front suspension are available. The telescopic fork and the leading link type ("lever type"). Both types are carried in the steering head on ball bearings.

Telescopic Fork

The telescopic front fork is equipped with inside springs and double-acting hydraulic shock absorbers.

The **front fork (Fig. 2.3-1)** is made up of **stem (8)**, the **steering column with bridge (16)**, **cross-piece (3)**, two fork legs with shock absorbers and the steering damper. Each fork leg is primed with 0.3 pints / 135 cc of oil through the holes of **tightening nuts (11)**.

Repairing the Telescopic Fork:

It is possible to partially dismantle or repair the fork without taking the entire assembly off the motorcycle.

Dismantling the front fork leg:

(with the front wheel removed, the front fork remaining on the motorcycle).

The required tool is mandrel 348-250 for mounting the seal body on the fork leg tube.

- unscrew the coupling nut tightening the fork leg tube to the cross-piece, pull up the shock absorber rod, loosen the shock absorber rod locknut and screw off the coupling nut
- insert the front axle into the fork left tip and use a radius wrench to turn off the seal assembly
- pull the fork leg tip down from the fork leg tube together with the shock absorber and the spring
- drain oil from the fork leg tip
- remove the circlips fastening the lower bushing of the fork leg tube, remove the lower bushing, the upper bushing of the fork leg tube and the seal assembly
- slacken by two to three turns the nut of the clamp bolt of the triple clamp ("bridge") and pull the fork leg tube down (to facilitate this operation, screw the coupling nut on the end of the fork leg tube by four to five threads and knock off the tube from the cross-piece taper by striking lightly with a rubber hammer).

Wash and inspect all the removed assembly units and parts, replace defective ones, if necessary.

Note: To drain oil remove shock absorber rod nut and top nut, remove table pinch bolt and remove complete tube and leg, turn upside down and drain the oil.

The positive and negative allowances between mating members provided by the factory are given in Table 2.3-1, and the tolerated limits of clearances and wear in the principal mating members are given in Table 2.3-2.

Check the condition of

- the cross-piece and bridge, look for cracks, bends, dents, deformation.
- the fork leg bushing and fork leg tubes, wear of friction surfaces, cracks, surface pitting.

- thrust bearings, look for cracks, scores, pitting on the face.
- oil seals, the working edges. Replace seals with worn lip.
- front shield and covers, look for mechanical damage, cracks, etc. Renew the paint, if damaged or corroded.

To reassemble the fork leg, lubricate the friction parts with motor oil and assemble in reverse sequence.

Use mandrel 346-250 when mounting the seal assembly on the fork tube. When driving the shock absorber rod into the coupling nut and locking it, ensure a clearance between the spring upper end and the nuts on the rod of .008 to .016 in / 0.2 to 0.5 mm to allow free turning of the coupling nut with rod.

The friction type **steering damper** (Fig. 2.3-1) is made up of two steel washers, moving (#37) and fixed (#39), two fiber washers (#17) and tightening bolt (#7) with a head. Friction between the steel and the fiber washers makes turning of the front fork more difficult.

WARNING: Over tightening the steering damper can make it very difficult to steer. With the Solo model, setting the steering damper too tight makes it very difficult to balance. Over tightening the damper on the sidecar motorcycle may cause the operator to initiate sudden weaving at highway speeds.

Leading Link Fork

The leading link front fork has a U-shaped front lever (sometimes referred to as a "pendulum") with suspension provided by two interchangeable hydraulic shock absorbers with external coil springs (Fig. 2.3-2).

In assembling the front fork it is important to ensure a clearance of .008 - .020 in. (0.2 - 0.5 mm) between the spring tip and the locknut of the nut tightening the fork leg tube so as to ensure free rotation of the tightening nut with the stem.

Repair of lever-type front fork includes the changes of the wheel lever silent blocks and dismantling and reassembling of spring-hydraulic shock absorbers.

Figure 2.3-1
Telescopic Front Fork

- 1 - Safety washer
- 2 - Seal
- 3 - Fork cross piece
- 4 - Steering column stem nut
- 5 - Supporting washer
- 6 - Spring washer
- 7 - Tightening bolt
- 8 - Steering column stem
- 9 - Bearing nut
- 10 - Top angular ball
- 11 - Tightening nut
- 12 - Top end of spring
- 13 - Packing ring of cover
- 14 - Leg cover with headlight bracket
- 15 - Union bolt
- 16 - Steering column bridge
- 17 - Friction washers
- 18 - Spring
- 19 - Collar
- 20 - Seal collar
- 21 - Seal spring
- 22 - Supporting ring
- 23 - Upper bushing
- 24 - Fork leg tube
- 25 - Fork leg tip
- 26 - Pin
- 27 - Damper body tube
- 28 - Damper body cone
- 29 - Damper fastening
- 30 - Lower bushing
- 31 - Lower guide of damper
- 32 - Damper piston
- 33 - Spring ring
- 34 - Damper rod
- 35 - Damper tube nut
- 36 - Rubber seal
- 37 - Moving washer
- 38 - Bottom angular ball bearing
- 39 - Fixed washer of steering damper
- 40 - Head tube of frame
- A - Cavity under piston
- B - Cavity above piston

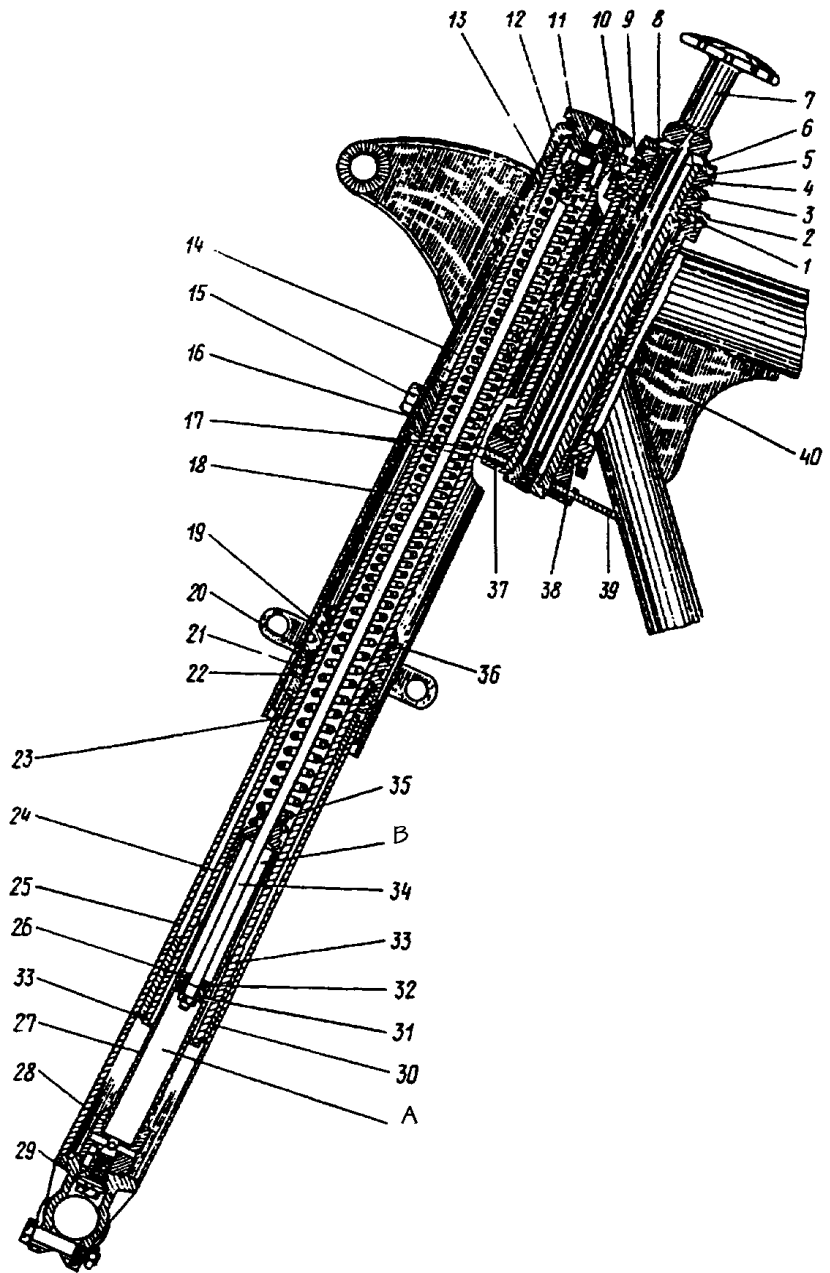

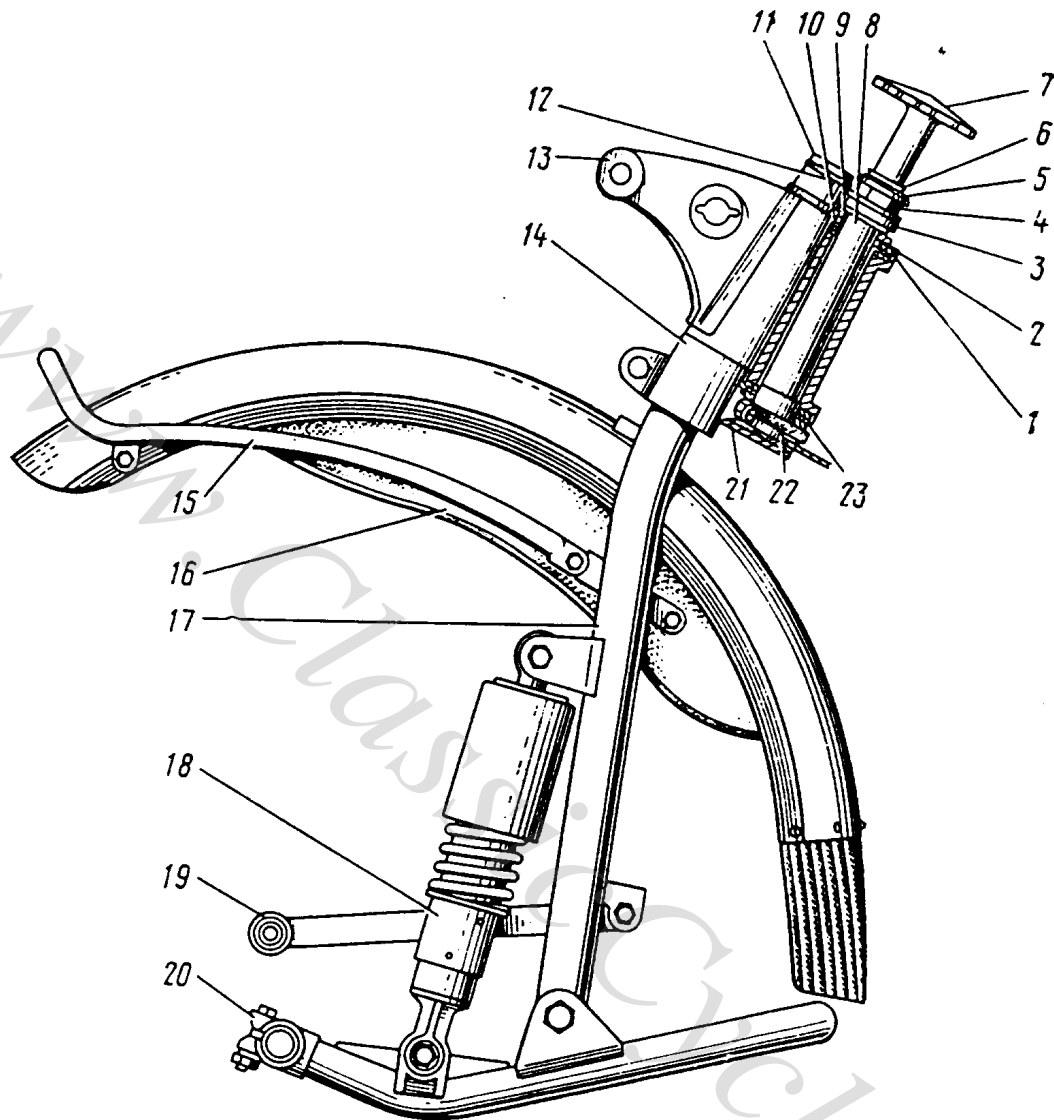

Figure 2.3-2 Lever-Type Front Fork

1 - Protective washer
 2 - Seal
 3 - Fork crosspiece
 4 - Nut of steering column stem
 5 - Supporting washer
 6 - Spring washer
 7 - Clamping bolt
 8 - Steering column stem

9 - Bearing nut
 10 - Upper radial-thrust ball bearing
 11 - Tightening nut
 12 - Washer
 13 - Leg housing with headlight bracket
 14 - Steering column bridge
 15 - Shock-absorber
 16 - Front fender

17 - Fork leg left tube
 18 - Spring-hydraulic shock absorber
 19 - Brake drum cover tie rod
 20 - Wheel lever
 21 - Moving washer
 22 - Steering column bridge
 23 - Lower radial-thrust ball bearing

Table 2.3-1 Rated Sizes, Positive and Negative Allowances Between the Principal Mating Members of the Front Fork, mm.

<i>Part No. and Name (shaft)</i>	<i>Rate size and tolerance</i>	<i>No. and name of mating member</i>	<i>Rated size and tolerance</i>	<i>Tolerated limits</i>			
				<i>Positive allow.</i>		<i>Negative allow.</i>	
				<i>Min.</i>	<i>Max.</i>	<i>Min.</i>	<i>Max.</i>
6208120 Fork leg tube bushing, lower	-0.032 42 -0.100	6308007 Fork leg tip, right-hand	+0.100 42	0.025	0.150		
6308101-10 Fork leg tube	-0.075 36 -0.160	6308120 Fork leg tip bushing, lower	+0.100 36	0.075	0.260		
6308101-10 Fork leg tube	-0.075 36 -0.160	6308113-01 Fork leg tube bushing, upper	+0.100 36	0.075	0.260		
6308113-01 Fork leg tube bushing, upper	42 -0.100	630/007 Fork leg tip, right-hand	+0.100 42	0.000	0.200		
6608151 Steering column stem	+0.145 28 +0.100	6308155 Steering column bridge	+0.045 28			0.055	0.145
6308155 Steering column bridge	+0.15 34 -0.010	72081-2 Radial-thrust ball bearing	34 -0.012		0.010		0.027

Table 2.3-2 Maximum Tolerated Limits of Clearances and Wear of Principal Mating Members of the Front Fork, mm.

<i>Name of parts and mating members</i>	<i>Maximum tolerances</i>	
	<i>Wear on Diameter</i>	<i>Diameter clearances</i>
Fork leg bushing, lower	0.15	
Fork leg tip	0.15	
Fork leg bushing, lower, to fork leg tip		0.30
Fork leg bushing, upper	0.80	
Fork leg tube	0.80	
fork leg bushing, upper, to fork leg tube		1.50

Steering head bearings

The steering head bearings must be adjusted periodically to avoid excessive play which might cause steering instability. When properly adjusted, the front fork should turn with just a hint of bearing drag, but neither free play nor obvious resistance to turning, with the steering damper relaxed.

WARNING: Improper adjustment of the steering head (e.g. too tight) will make the motorcycle very difficult to steer. This is a critical adjustment for proper handling of all models. Loose steering head bearings can contribute to sudden front end oscillations. Tight bearing adjustment makes it difficult to control the motorcycle.

To adjust the steering head bearings:

- Jack the motorcycle front wheel off the ground.
- Undo the tightening bolt of the steering damper, remove the spring and the supporting washers, holding the damper washers by hand.
- While rocking the front fork up and down with either the handlebar or the fork leg tips, determine if there is any play.
- Rotate the front end, determine if there is excessive resistance at any point of rotation, or notching of bearings.

If play in bearings is evident, remove the handlebars and lay towel on gas tank to protect paint; lay bars on tank. Unlock and slacken off nut (4) of the steering column stem, remove tightening nuts (11) of the fork legs, and remove cross-piece (3) with the nut. Tighten bearing nut (9) until snug, release it 1/8 - 1/6 of revolution, and check bearing clearance. The front fork should rotate freely with no perceptible play. Reinstall the cross-piece in place, tighten up the nuts including lock nut (4), and recheck clearance again. When clearance is acceptable, reinstall the steering damper.

Note: If the front end tends to "stick" in several positions, that indicates notched bearing races which should be replaced. Replacement of steering head bearings and races requires removal of the front fork.

Removing and Reinstalling the Front Fork

To remove the front fork:

- disconnect the front brake cable
- remove the front wheel and the brake drum cover
- disconnect the horn
- undo the steering damper tightening bolt and remove all the steering damper washers
- disconnect the handlebar brackets, remove the handlebar, and tilt it back on the fuel tank with cables and wiring intact
- remove the pilot lamp sockets and speedometer lamp
- disconnect the speedometer drive shaft and daily speedometer release knob cable, and remove the control panel

- unscrew the tightening nuts of the fork legs and the steering column stem nut, remove the washers and the fork crosspiece

- remove the bolts fastening the front fender (mudguard) to the leg covers and the steering column bridge
- remove the direction indicator relay and fuse block bracket and the front mudguard
- disconnect the wires from turn indicator terminals. As a precaution against damage, remove the turn indicator from the front fork
- unbolt the headlamp from the leg cover brackets and take it off
- unscrew and remove the ignition lock from the leg cover bracket
- hold the front fork in position while removing the bearing nut, safety washer of the thrust bearing, upper bearing race, and seal
- carefully pull the front fork down out of the steering head.

Note: The ball bearings in the steering head are loose. Take care to catch any bearings which fall out, then remove the remaining bearings and count the total. There must be 44 balls total.

If bearings or races show pitting, notching, or other damage, both races and balls should be changed. Races can be removed quickly by arc welding one or two small spots on the bearing surface, which will shrink the race as it cools. When installing a new bearing race, ensure that the bearing land in the frame is clean and free of burrs which could prevent true seating of the race. Use a suitable puller to draw the bearing races into the steering head without distorting or damaging the parts.

To reinstall the front fork, reverse the sequence of the operations. When reassembling the fork in the steering column, pack the bearing races with heavy grease such as wheel bearing grease to hold the ball bearings in place and provide permanent lubrication. Count the balls to ensure that all 44 are in place and intact. When tightening the bearing nut, adjust it to provide zero clearance, i.e. unobstructed rotation of the fork in the bearings, without seizing and with no noticeable play (tighten it snugly, then loosen 1/12 of a turn, approximately 30 degrees).

Note: The tightening torque of the steering column stem nut should be 100 - 120 ft/lbs. The bearing nut should be tightened to 22 - 26 ft/lbs.

2.4 Rear Suspension

The rear wheel is suspended on a trailing swingarm, pivoting on rubber (silent block) bushings located by removable pins in the frame, and supported by dual hydraulic shock/springs. The final drive bolts to the right side of the swingarm.

2.5 Brakes

The motorcycle is equipped with shoe type brakes on both motorcycle wheels and the sidecar wheel. The brake drums are integral with the wheel hubs. Each brake drum cover supports the shoes and actuation levers. All brakes are the same overall diameter, so all wheels are interchangeable.

NOTE: When removing brake shoes make sure that they are replaced in the exact position they came from. If installed upside down the brake may not work.

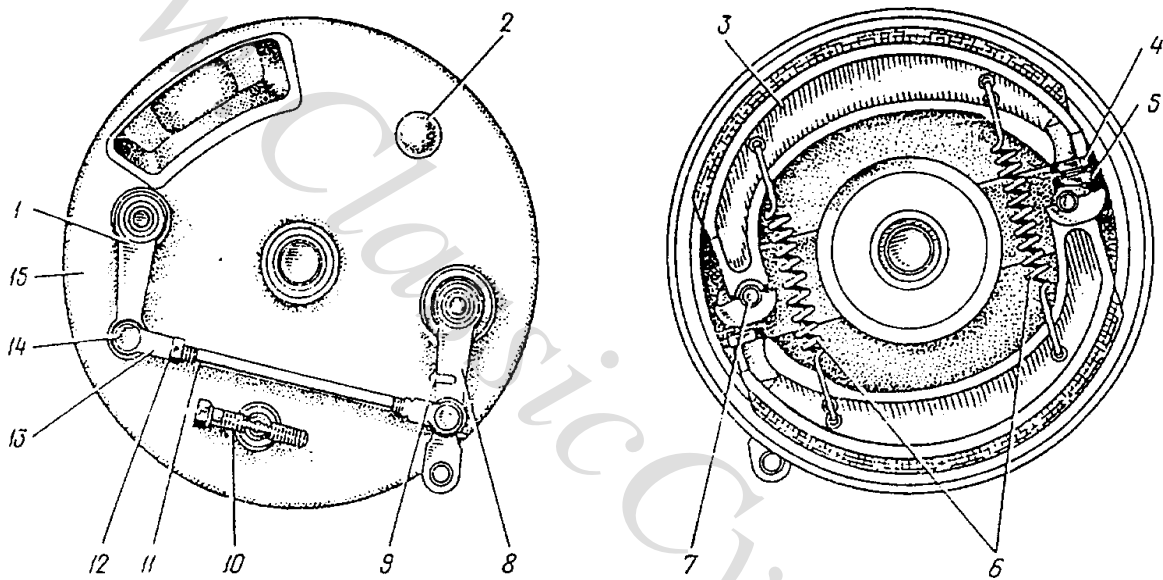

Figure 2.5-1 Front Wheel Brake

- | | |
|-----------------------------------|-------------------------------|
| <i>1 - Top brake lever</i> | <i>9 - Brake lever spring</i> |
| <i>2 - Inspection hole plug</i> | <i>10 - Adjusting screw</i> |
| <i>3 - Brake shoe</i> | <i>11 - Tie rod</i> |
| <i>4 - Adjusting bolt locknut</i> | <i>12 - Locknut</i> |
| <i>5 - Adjusting bolt</i> | <i>13 - Tie rod fork</i> |
| <i>6 - Brake shoe springs</i> | <i>14 - Pin</i> |
| <i>7 - Front brake cam</i> | <i>15 - Brake drum cover</i> |
| <i>8 - Bottom brake lever</i> | |

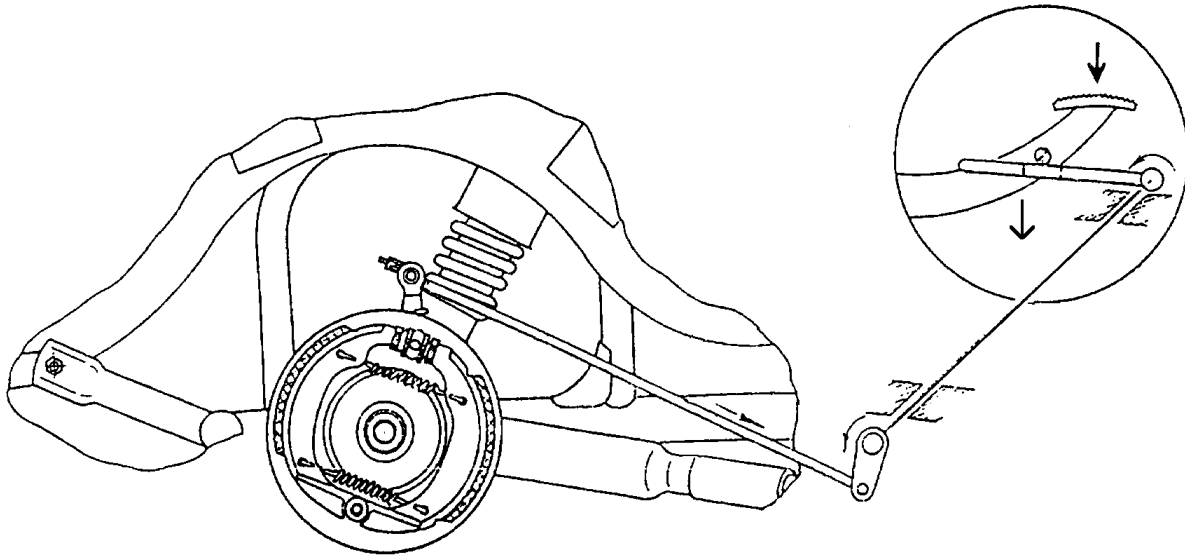

Figure 2.5-2 Sidecar Wheel Brake

The front wheel brake (Fig. 2.5-1) has double leading shoes actuated by separate cams. Tie rod (11) of the upper and lower levers of the brake is factory-adjusted to length so as to equalize the brake cams. To return the levers to their initial position when the brake lever is released, a spring (9) is installed on the bottom lever. The rear wheel and sidecar wheel brakes are both single leading shoe.

The brake shoes are provided with adjusting bolts (5) to compensate for the wear of the shoe linings. The adjusting bolts control the gap between the brake shoes and the brake drum. For normal performance of the brake, there must be a correct gap between the shoes and the drum. If there is no gap, the linings rubbing on the brake drum will overheat and cause rapid wear of the linings. Tight shoes may even expand sufficiently to seize the drum. However, if the gap is too large, the brake cannot be applied with full force.

Brake shoe gap can be measured through inspection holes in the cover of the brake drums and final drive case. Inspection holes are closed with rubber plugs.

Brake Adjustment

Note: The front brake lower lever is set at a distance of 85 mm (3.3 in) from its vertical axis to the adjusting screw bracket center. Angle of deviation of the rear brake lever backward from the vertical axis of the final drive equal to $(33\pm 5)^\circ$ should be ensured after necessary disassembly of the lever with the brake shoes cam. The brake adjustment is performed with the wheels jacked up.

The front wheel brake is adjusted by an adjusting screw located on the drum cover and the foot brake, by an adjusting nut situated on the rear end of the brake tie rods.

Proceed to adjustment of the foot brake starting from the rear wheel, having first slackened the nut on the tie rod of the sidecar wheel brake. Then adjust the sidecar wheel brake by tightening the nut on the brake tie rod. After the foot brake has been adjusted properly, back up the nut on the tie rod of the sidecar wheel brake by 2 - 3 turns so as to preclude a sideways deflection of the motorcycle on braking.

Brakes should be "burnished in" during the initial running in (break in) period. Speeds during this period should not exceed 42 mph for "Tourist" and "Patrol" models, 50 mph for "Solo" and "Cruiser" models (see "Speeds for Running-in" table). Follow burnishing procedures carefully. Make approximately 100 stops using 75% of full braking power. This can be done over several periods and need not be done in one session. Choose an area with clean, dry pavement and no obstructions. Travel in a straight line and apply both the hand (front) brake as well as the foot (rear and sidecar) brakes.

After burnishing the brake shoes, adjust your brakes on each wheel to reduce the gap between shoes and drums. This procedure will ensure maximum braking performance during the running-in period and is essential before raising your top speed, after your URAL® has been carefully run in (after 2,500 km).

WARNING: Because brake performance is a critical safety item, we recommend brakes be inspected and adjusted at every service interval. Brakes must be inspected for wear every 2,500 - 5,000 km. If the brake shoe friction material is 1/16 in. thick or less (the thickness of a nickel) the shoes must be replaced.

If the motorcycle is ridden under adverse conditions, (steep hills, heavy traffic, etc.) inspection every 1,000 km is recommended. All three brakes should be used, even for normal stops.

The sidecar wheel brake is mounted on the sidecar axle, and connected to the rear brake pedal via a torsion rod and slotted lever (Fig. 2.5-2). The sidecar brake drum cover is held from rotation by a torque stop on the sidecar swing arm. Sidecar brake shoes are interchangeable with the motorcycle brake shoes.

Note: If there is excessive play in the sidecar brake torque stop, the brake will self-actuate as the sidecar rolls backwards. Play can be removed by installing a shim.

CAUTION: When installing the sidecar wheel, it is necessary to have a distance shim on the axle, against which the inside wheel bearing is positioned. Without the shim in place, the brake drum will contact the brake shoes and cause a grinding sound. If the sidecar brake drum appears to be "dragging", check for correct placement of the distance shim.

2.6 Wheels, Tires, Shock Absorbers and Springs

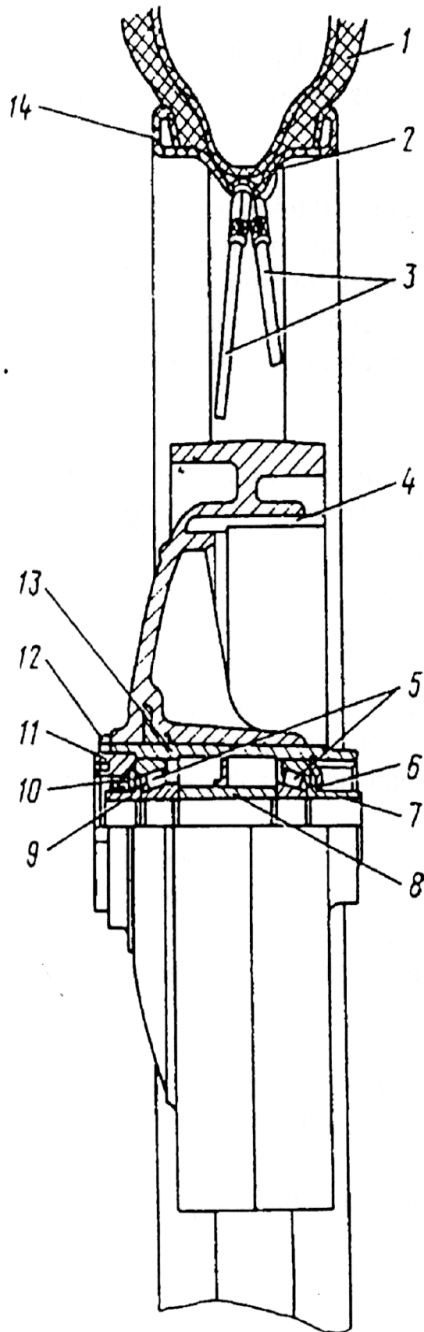

Figure 2.6-1
Motorcycle Wheel

- 1 - Tire
- 2 - Tire flap
- 3 - Spokes
- 4 - Brake drum
- 5 - Roller bearings
- 6 - Thrust washer
- 7 - Right-hand distance bushing
- 8 - Intermediate bushing
- 9 - Left-hand distance bushing
- 10 - Seal
- 11 - Seal nut
- 12 - Locknut
- 13 - Hub
- 14 - Wheel rim

The URAL[®] motorcycle is equipped with easily demountable and interchangeable wheels. Inner splines provided on the right-hand side of the hub receive the splined end of the final drive hub in case the wheel is used as a drive wheel. The aluminum hub contains a brake drum, and connects to the steel rim via heavy gauge spokes of equal length. Individual spokes can be replaced if damaged.

Wheel bearings are installed in each wheel.

Tires are tube-type, using an inner flap between the spokes and inner tube to protect the tube from damage. Rim locks are not used in the stock configuration. Care should be taken to keep tires properly inflated. See *Specifications*, for correct cold tire inflation pressures.

WARNING: Improper tire inflation will cause abnormal tread wear and could result in unstable handling. Under inflation will cause tire overheating, and could result in the tire slipping on the rim. Over inflation reduces traction, and can cause both tire and rim damage. Inflation pressure should be checked, and the treads inspected for punctures, cuts, breaks, etc., at least weekly if in daily use, or before each trip, if used occasionally.

WARNING: Riding with excessively worn, unbalanced or improperly inflated tires is hazardous and will adversely affect traction, steering and handling. Replacement tires should be the same size, profile, and construction of the original equipment tires, especially for sidecar use.

Adjustment of wheel bearings.

After 5,000 km run be sure to check the condition and adjustment of the bearings. With the axle nut tightened, the wheel should be free to rotate without drag or noise, and there should be no lateral play in the bearings. Wheel bearings are adjusted as follows.

1. Remove the wheel from the motorcycle.
2. Fit the rear wheel axle (less the protective hood), tighten it by nut with the aid of a bushing, 100 mm long, with 21 mm bore and 25 - 30 mm O. D. (or any spacers which will allow the axle nut to snug up the bearings).
3. Determine whether there is play by turning the axle (but not the wheel on the axle) and rocking it in the hub.
4. Slacken off the locknut.
5. Screw the seal nut up to the limit, then loosen it by 1/6 - 1/8 of a revolution so that the axle can still be rotated in the bearings easily but without excessive play or drag.
6. Tighten the locknut securely without disturbing the adjustment of the bearings.

Removing and Reinstalling Wheels

All three wheels on the URAL® are interchangeable.

To remove the front wheel:

1. Set up the motorcycle on the stand and jack up the front wheel by inserting a block or floor jack under the front part of the motorcycle frame.
2. Slacken off the axle clamp bolt on the left fork leg, and unscrew the front axle. *Note: The axle has left-hand thread.*
3. While supporting the wheel, remove the front axle and take the protective cap off the wheel.
4. Remove the front wheel together with the brake drum cover.
5. Separate the wheel from the brake drum cover. Note the position of thrust washers, packings and hubcap.

To reinstall the front wheel, reverse the sequence of the operations. When mounting the axle, lubricate it with motor oil or a thin film of grease.

To remove the rear wheel:

1. Set the motorcycle on the stand, raising it up on blocks of wood to provide more clearance.
2. Remove the cotter pin of the axle slotted nut, unscrew the nut, loosen the axle clamp bolt on the left-hand side of the swing arm and remove the axle together with the protective cap.
3. Shift the wheel off the brake shoes to the left and remove the wheel from the frame.

Before installing an axle in place, lubricate it with motor oil or a light film of grease. When fitting the wheel over the brake shoes, rotate the wheel as necessary to engage the coupling splines of the hub.

To remove the sidecar wheel:

1. Raise the sidecar frame with blocking or a floor jack to lift the sidecar wheel.
2. Take out the cotter pin, undo the nut and remove the protective cap;
3. Pull the wheel off the axle.

Note: Removing the sidecar wheel may be easier if the sidecar brake rod is slacked off several turns to allow the brake shoes to retract.

To reinstall the sidecar wheel, reverse the sequence of the operations. Prior to mounting, lubricate the axle. The bearing washer must be on the axle before the wheel is replaced on the axle.

Note: Front and rear motorcycle axles should be tightened to correct torque on installation. Correct axle torque is 55 foot-pounds / 75 Nm.

Checking Wheel Condition

Having removed the wheel and prior to repairs, check:

- wear of tires and possible damage
- cracks and dents of the wheel rim
- wear on the brake drum surface
- wear in the wheel bearings and spacers
- radial and side runout of the rim and tire
- presence and uniform tightening of all the wheel spokes

Condition and adjustment of the bearings in wheel hubs is best checked by rotating a tightened axle in the wheel hub rather than by rotating and rocking the wheel on the axle. Due to the considerable weight of the wheel over-tightening of the bearings may be difficult to detect. The axle should rotate freely, without noticeable runout, seizing, clicks, etc.

Radial and side runout in a wheel may be tolerated within .060 inch / 1.5 mm for the wheel rim and within .120 inch / 3 mm for the tire. Repair the wheels if any defects are revealed.

Dismounting and Remounting the Tire (with the wheel removed)

The OEM tires furnished by Ural are better suited to URAL® use than the majority of today's standard motorcycle tires. Because tires, tubes and wheels are critical safety items, and servicing of these items requires special tools and skills, we recommend that all tire servicing be done by the dealer. URAL®

tires that have been tested by the manufacturer to ensure compliance with DOT requirements are available from Ural dealers.

When tires are worn to a tire center tread depth of 3/32 in., they should be replaced.

Correct tire inflation data can be located on the sidewall of the tires mounted on your particular model of URAL.

WARNING: Maximum inflation pressure must not exceed specification on tire sidewall.

Tire Changing Procedure

1. If tire is to be re-used, mark valve stem location on tire.
2. Remove valve cap and valve, push the valve stem inside the tire;
3. Break the tire bead away from the rim. The tire beads of tube-type URAL® tires should separate using only tire irons.
4. Remove the tire, using either a tire machine or tire irons.
5. Use tire lubricant or liquid soap solution to help prevent damage to the bead when dismounting or mounting.

After dismounting, inspect inner surface of the tire for damage or imbedded objects. Be certain there are no foreign objects such as nails or glass shards in the tire tread which could penetrate the cords. A tire which has been punctured should be checked for cord damage. It is preferable to always use a new inner tube, whether repairing a puncture or installing a new tire. Cold patches are not recommended as a permanent repair.

To remount the tire and the inner tube, proceed as follows:

1. Check that no spoke nipples protrude inside rim. If spoke ends protrude beyond the head of the nipple, the spoke should be ground flush, with a grinder or file.
2. Fit on the rim flap to protect the inner tube from being punctured by spokes or spoke nipples. Position the hole in the rim flap to coincide with the valve stem hole in the rim.
3. Powder the inside of the tire casing with talcum to help the inner tube stretch into position upon inflation.
4. Lubricate the tire bead with soap solution on one side and install that bead over the rim. If reinstalling a used tire, position the tire in same relative position as removed, to help maintain original balance.
5. Replace the valve core, inflate the tube slightly and insert it into the tire casing, making sure that it is spread uniformly without any wrinkles;
6. Work on the other tire bead, beginning from the area opposite to the valve stem. Take care to avoid pinching the inner tube with the tip of a tire iron when mounting the tire by hand.
7. Lubricate the entire bead with soap solution on both sides and seat the beads by inflating the inner tube.

Note: Markings that refer to circumference on sidewall of tire will be equidistant from rim when tire is correctly seated. Failure of the inner tube to hold air pressure is usually an indication the tube has been punctured with a tire iron. Mounted tire should be round and true within 0.12 inch / 3 mm.

WARNING: Do not use excessive pressure to seat a reluctant tire bead. Tires and wheel rims can suddenly explode if inflated beyond recommended pressures. A tire should seat with normal pressures when lubricated. If the tire does not seat, deflate it, check that the inner tube or rim flap are not captured under the tire bead, especially near the valve stem, and lubricate the bead again before inflating.

WARNING: For your own personal safety, tires and tubes must be correctly matched to wheel rims. Mismatching tires, tubes and rims may result in damage to the tire bead during mounting or may allow the tire to slip on the rim, possible causing tire failure. In addition, using tires other than those specified may adversely affect motorcycle stability. Tire sizes are molded on the tire sidewall. Tube sizes are printed on the tube.

When the tire has been mounted and seated correctly, check balance of the wheel/tire assembly, and if necessary, rebalance using spoke weights.

Dismantling and Reassembling the Wheel Hub (with the wheel removed)

The required tool is mandrel 345-324-3 for removing the roller bearing cup.

To dismantle the wheel hub:

1. Loosen locknut, undo the seal nut and remove the left-hand distance bushing.
2. Insert the mandrel on the wheel axle on the splined hub side and press out the end roller bearing, intermediate bushing, second roller bearing cone and right-hand distance bushing.
3. Using mandrel 345-324-3 press out the thrust washer and the roller bearing cup.

Wash and inspect the dismantled parts. Change any defective parts.

Reassemble the wheel hub as follows:

1. Fit the thrust washer and the right-hand distance bushing into the hub, inserting the shoulder of the bushing into the thrust washer groove.
2. Pack the bearings with wheel bearing grease, and press in the bearing and bushings in the reverse order they were removed.
3. Press the rubber collar into the oil seal nut arranging it so that the oil catching edge and the spring are inside the nut.
4. Insert the left-hand bushing into the seal nut from the side facing the bearing, and torque the nut to the specifications to properly seat the bearing races.

Tightening torque: 12 ft lb. / 16 Nm

1. Turn off the nut by 1/6 to 1/8 of a revolution and lock with a locknut.

After reassembling, check the bearings for proper clearance, and adjust, if necessary.

To perform this check:

1. Insert the axle into the reassembled wheel hub with an appropriate spacer, and tighten the axle nut to pull the bearings tight. (rear axle nut).

2. Check bearing clearance by rotating and attempting to rock the axle. The axle should be free to rotate, with no noticeable play or abnormal noises. To adjust, unscrew the locknut and readjust it.

CAUTION: Over-tightening of bearings or excessive bearing play will lead to premature wear of bearings. With a properly assembled hub, the left-hand distance bushing should protrude from the rubber collar within 1.0 to 2.0 mm / 0.04 to 0.08 in. If otherwise, change the faulty bushing.

Repairing the Wheel

Required tools: spoke wrench, wheel truing stand, file or hand grinder

Wheels should only be checked for trueness with all spokes intact and tensioned. Individual damaged spokes can be replaced, but the wheel should then be trued.

It is advisable to replace the wheel hub or rim when:

- the brake drum working surface is worn-out
- the hub splines are worn-out
- bearing races become loose in the hub
- the wheel rim is cracked, dented or bent beyond repair

Before proceeding to replace either the hub or the wheel rim, compare the cost of a new wheel against the probable labor required to respoke and true the wheel, plus replacement parts. There are shops that specialize in respoking and truing wheels.

Shock Absorbers and Springs

Suspension (except for front tubular forks) is by hydraulic shock absorbers with external coil springs (Fig. 2.6-2). The supporting spring (4) serves as an elastic element of the suspension, while its oscillations are damped by the double-acting hydraulic absorber enclosed in body (7).

The suspension features cam-type adjusters (cams 11 and 12) used for preloading the springs to suit the load and the road condition. When the motorcycle is carrying heavier loads, spring preload should be increased.

Care of Shock Absorbers

Change hydraulic fluid every 10,000 km. Fill the shock absorber with 105 cc of hydraulic fluid or light shock fluid. Each time during maintenance, check the bolts fixing the top and bottom ends of the shock absorbers for tightness.

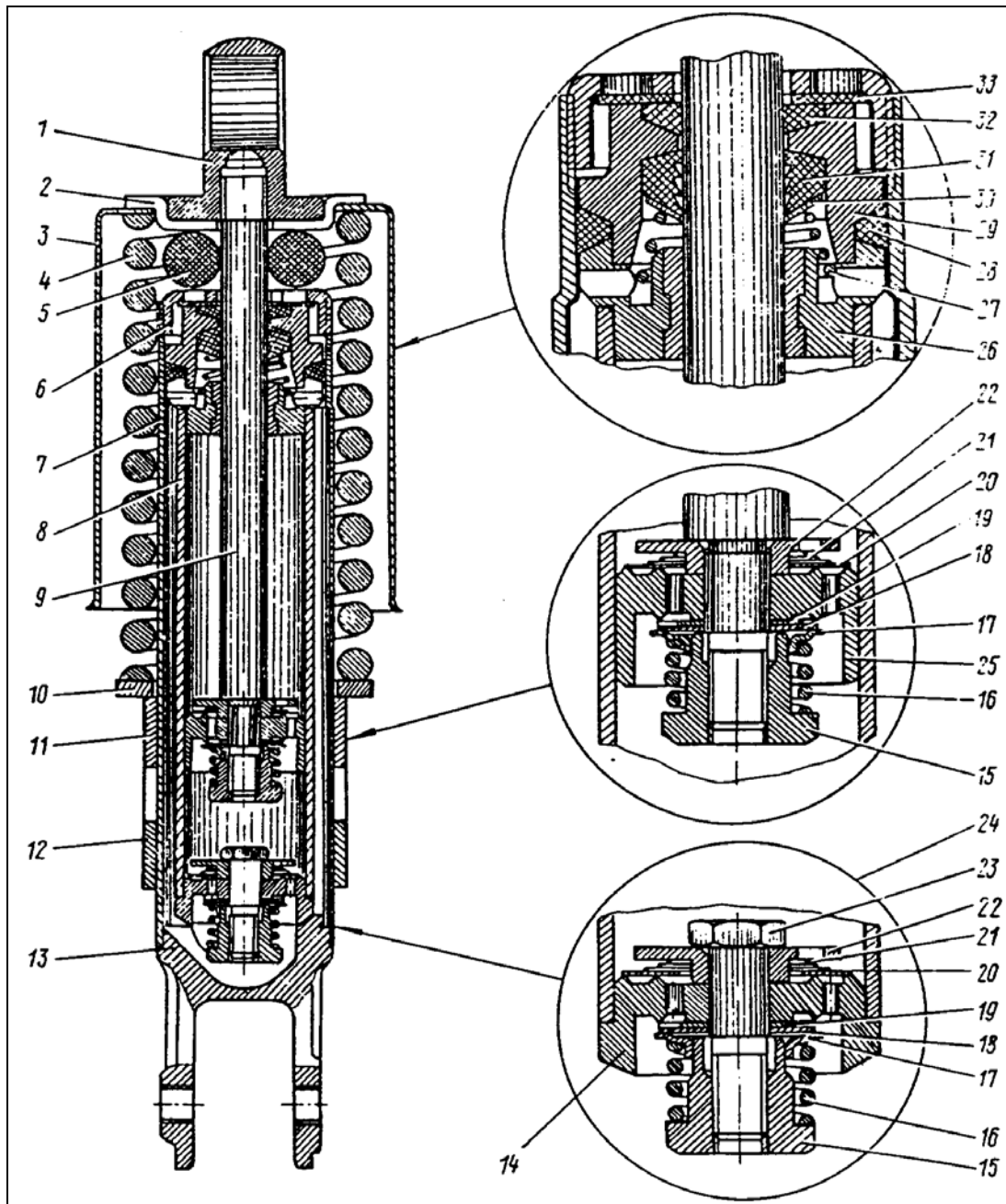

Figure 2.6-2 Spring-Loaded Hydraulic Shock Absorber

- | | | |
|-------------------------|-----------------------------------|------------------------------|
| 1 - Upper tip | 12 - Fixed cam | 23 - Compression valve stem |
| 2 - Retainer | 13 - Lower end piece | 24 - Compression valve assy. |
| 3 - Housing | 14 - Compression valve body | 25 - Piston |
| 4 - Spring | 15 - Rebound valve nut | 26 - Rod guide |
| 5 - Buffer | 16 - Rebound valve spring | 27 - Seal spring |
| 6 - Barrel nut | 17 - Rebound valve retainer | 28 - Container nut seal |
| 7 - Shock absorber body | 18 - Rebound valve plate | 29 - Seal holder |
| 8 - Working cylinder | 19 - Rebound valve throttle plate | 30 - Seal washer |
| 9 - Rod | 20 - Intake valve plate | 31 - Rubber seal of rod |
| 10 - Check ring | 21 - Bypass valve spring | 32 - Felt seal of rod |
| 11 - Moving cam | 22 - Bypass valve retainer | 33 - Pressure washer |

2.7 Fenders

All three URAL® fenders ("mudguards") are of heavy gauge formed steel. Removal and attachment should be obvious. Dented fenders may be hammered straight and repainted, using standard automotive techniques, although it may be more economical to simply replace the fender.

When installing fenders, ensure that all fasteners are snug, to ensure that a fender does not drop down and jam into a tire during motorcycle operation.

2.8 Bench Seats

The bench seat is a stamped steel frame to which is attached a foam cushion with a vinyl cover.

Removing and Reinstalling the Bench

To remove the seat, undo the nut located under the front portion of the seat, raise the seat and move it forward. To reinstall the seat, proceed in reverse order, but without pressing the latch.

2.9 Windshield and Fairing

Different URAL® models may be equipped with windshields or handlebar fairings of various design.

Semi-Fairing

When assembling the URAL® "Semi-Fairing", loosely connect the metal parts, then attach the "Slipstreamer" windshield, and gradually snug up the fasteners. Do not overtighten fasteners attaching the plastic windshield, which could cause the material to crack.

Classic Fairing

In order to properly install the Classic Clear Fairing to a URAL® Motorcycle, adjustments must be made to the manufacturer's original instructions. The following parts are not required for installation and have been removed from the package: 4 rubber gaskets/pads, 2 fork tube mounting hardware. The of slot #1 comes as 7mm; it must be increased to 8mm.

After completing the assembly of the windshield and hardware, follow the steps listed on the following page for installation onto a URAL®.

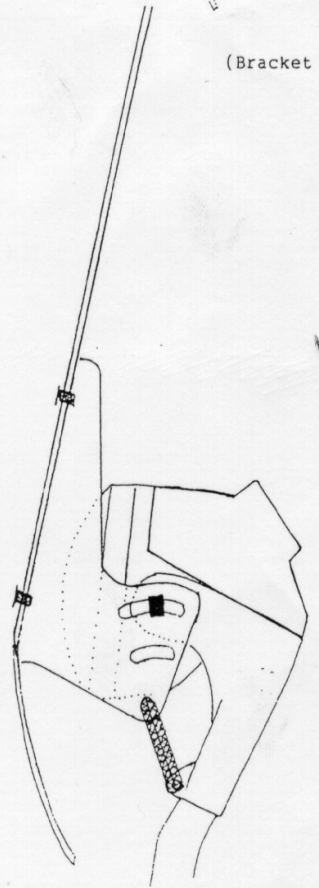
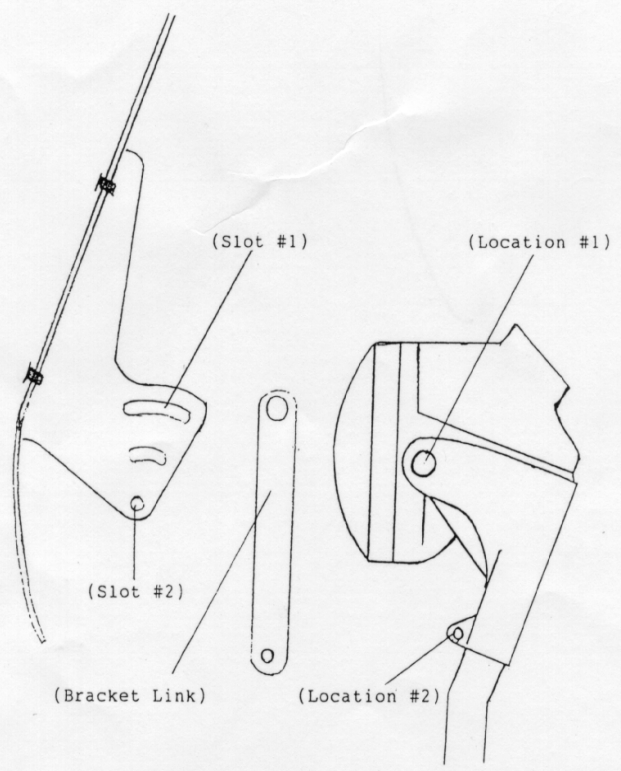

1. Remove the bolt at location #1 (one on each side of the headlight) which holds the headlight assembly to the fork covers.
2. Place the chrome mounting bracket on the outside of the painted fork covers, position slot #1 over location #1.
3. A rubber washer has been provided if necessary to prevent contact between the chrome hardware and painted fork covers.
4. Replace the bolt into location #1 (one on each side of the headlight), do NOT tighten completely at this time.
5. Connect one end of the bracket link to slot #2, and the other side of the bracket link to location #2, which is the turn signal mount.
6. Tighten all bolts.

Sidecar

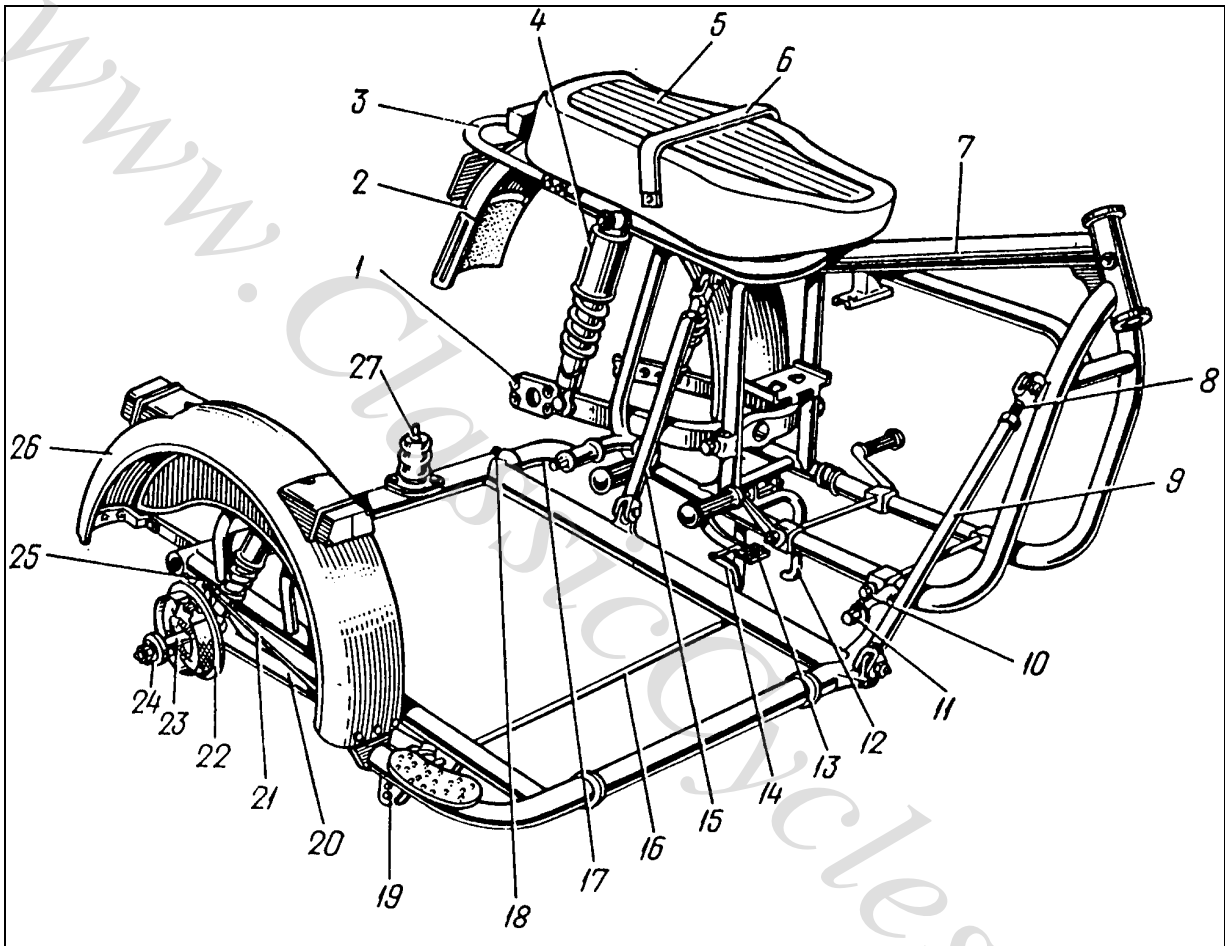

Figure 3.0-1. Motorcycle and Sidecar Frames

- | | | |
|--|----------------------------------|---------------------------------------|
| 1 - Rear suspension swinging arm | 10 - Collet clamp | 20 - Lever |
| 2 - Rear mud shield | 11 - Collet clamp screw | 21 - Brake tie rod |
| 3 - Rear grab bar | 12 - Motorcycle stand | 22 - Brake drum cover |
| 4 - Spring loaded hydraulic shock absorber | 13 - Brake pedal | 23 - Sidecar wheel axle |
| 5 - Bench Seat | 14 - Sidecar wheel brake lever | 24 - Protective hood |
| 6 - Strap | 15 - Sidecar frame legs | 25 - Tie rod nut |
| 7 - Motorcycle frame | 16 - Sidecar wheel brake rod | 26 - Sidecar wheel nut fender |
| 8 - Leg adjusting fork | 17 - Rear collet clamp bracket | 27 - Rubber member of body suspension |
| 9 - Sidecar frame legs | 18 - Rear bracket fastening bolt | |
| | 19 - Lever pins | |

3.1 Description and General Specifications

The URAL® sidecar is a large diameter tubular steel frame with a trailing link swing arm wheel suspension, to which is attached a body. The sidecar is rigidly attached to the motorcycle by two lower ball/collet clamps, and two upper adjustable struts ("legs"). The sidecar is aligned by adjusting the lower rear connector and the two upper struts.

There are two body styles, one for carrying passengers, the other for cargo only. Both body styles are constructed of sheet steel, spot welded. The passenger body is suspended on the sidecar frame by hollow rubber support blocks at the rear, pivoting on rubber bushings at the front frame member, to provide shock damping for passenger comfort. On the passenger model, there is a cushioned seat made in two parts, the lower seat, and the seat back. Both parts are removable. The rear of the sidecar body is a trunk, accessed via a hinged lid.

The passenger body incorporates a forward-pivoting windshield, composed of two vertical chromed steel tubes connected by a steel cross piece, and a clear plastic windshield. The windshield is held in position by a vinyl apron attached to the body clips via straps. The windshield is tilted forward to aid in passenger entry, and tilted back for operation. A tonneau cover is supplied to enclose the passenger area. Normally, the tonneau cover is attached under the windshield apron, and folded back over the passenger's legs when a passenger is carried.

The sidecar fender is formed steel, supported on the main frame by a tubular member that also serves as the upper shock absorber mount for the wheel suspension. The fender incorporates front and rear lights, including both clearance and turn signal.

The two-wheel drive Patrol model is identical to the single wheel drive model, except for a shaft drive from the motorcycle final drive to the sidecar wheel, a driven sidecar wheel hub. The sidecar body is slightly higher on the frame to allow clearance for the drive shaft, and the sidecar rear mounting points are farther back to clear the sidecar drive shaft. The Patrol also comes with a 10 L fluid container, which is optional on other sidecar models.

3.2 Installation and Removal

To detach the sidecar:

1. Set up the motorcycle on the stand.
2. Disconnect the plug-and-socket connector leading to the sidecar lamps.
3. Undo the nuts of upper bolts fastening the sidecar frame tie-rods to the motorcycle and extract the bolts.
4. Slacken off the bolts of bottom clamping holders which fasten the sidecar frame to the motorcycle sufficient to allow the jaws to clear the ball pins.
5. Disconnect in turn the front clamping holder, then the rear clamping holder by lifting them off the ball pins.

To attach the sidecar to the motorcycle:

1. Set the motorcycle on the stand.
2. Smear the ball pins lightly with grease.
3. Drag the sidecar towards the motorcycle until the jaw clamps fall directly under the ball pins of the motorcycle frame.
4. Unscrew the bolt and push the front clamping jaws out of the socket far enough to allow them to spread over the ball pin.
5. Raise the front end of the sidecar frame to fit the clamping arms on the front ball pin and tighten the bolt loosely.
6. Attach the rear clamp in a similar manner. If the rear clamp doesn't center on the ball, support the rear of the sidecar, loosen the clamping bolt on the rear sidecar frame tube, and rotate the rear clamping arm to match the ball position, then tighten the clamping bolt.
7. Bolt the tie-rods fastening the sidecar frame to the motorcycle frame and lock the bolts with nuts.
8. Reconnect the sidecar lamp wire connector.

Note: If either tie-rod connector fork fails to coincide with the hole in the motorcycle frame bracket, loosen the locknut and screw the fork in or out to fit.

Tighten fasteners to take up all play, and check sidecar alignment as described in the next section.

3.3 Sidecar Alignment

The sidecar must be aligned in a definite position relative to the motorcycle. The sidecar wheel is angled slightly towards the front of the motorcycle, and the motorcycle itself must be leaned out, away from the sidecar (Fig. 3.3-1). **An incorrectly aligned sidecar will drag the motorcycle to either side , which not only makes the combination difficult to handle, but also causes excessive tire wear.** It is very important to check sidecar alignment at scheduled maintenance intervals. If the motorcycle is not stable on the road and is difficult to steer, check alignment as well as steering head bearing adjustment.

Alignment is best accomplished on a smooth level floor.

Toe-in

Toe-in is checked by placing a straight edge along the motorcycle wheels and a straight edge along and the sidecar wheel, and measuring the distance between the two straight edges. A solid straight edge helps hold the front wheel in line with the rear wheel, and forms a measurement line parallel to the centerline of the motorcycle. The spacing between the straight edges at front and rear determine the toe-in. Measurement points are below the front and rear axles of the motorcycle. Take care to measure along a line perpendicular to the straight edge, and to keep both straight edges in contact with the tires.

Recommended toe-in is 3/8 inch / 10 mm. That is, toe-in is correct when spacing between the two straight edges at the front axle is 3/8 inch / 10 mm less than that at the rear axle. Toe-in is adjusted by easing off the fastening bolt holding the lower rear clamping bracket in the sidecar frame, and sliding the clamping bracket in or out of the sidecar frame tube. Adjusting the position of the rear clamping bracket also affects the position of the upper rear strut ("tie-rod"), so the upper strut bolts should be slacked off while making the toe-in adjustment, and lean-out will subsequently require correction.

Lean-out

Recommended lean-out is 1 degree. That is, the motorcycle should lean out (away from the sidecar) approximately 1 degree, with the motorcycle resting on wheels, not the center stand, and the suspension compressed with the approximate weight of the operator (1 degree lean-out is equivalent to approximately 1/2 inch / 12 mm lean-out between handlebar level and floor). If the motorcycle is on a level floor, lean-out can be checked using a level gauge and a protractor, or with a plump bob and a ruler. When installing a new sidecar for the first time, lean-out can be estimated by observing the motorcycle from the rear with an operator sitting on the saddle. The motorcycle should lean perceptibly to the left, not perpendicular to the floor.

Adjust leanout by easing off torque on the lower collet bolts, loosening the lock nuts on the upper struts (the two inclined legs), removing the upper strut attachment bolts, and screwing the forked clevises in or out.

NOTE: When making either toe-in or lean-out adjustments, make corrections in small increments, then recheck. Very small adjustments in position of the rear connector will have large results in toe-in.

CAUTION: With both bolts removed from the sidecar struts, the motorcycle can tip away from the sidecar, with subsequent damage to fittings. Manually support the motorcycle when making the leanout adjustment.

When leanout is adjusted to the recommended specifications, snug up all connectors, then recheck toe-in. Fine tuning of leanout is accomplished by road testing the motorcycle.

Tighten all bolts securely. Tightening torques are:

- collet clamping bolts
25 ft/lb. / 40 Nm
- sidecar tie-rods
33 ft/lb / 4 Nm

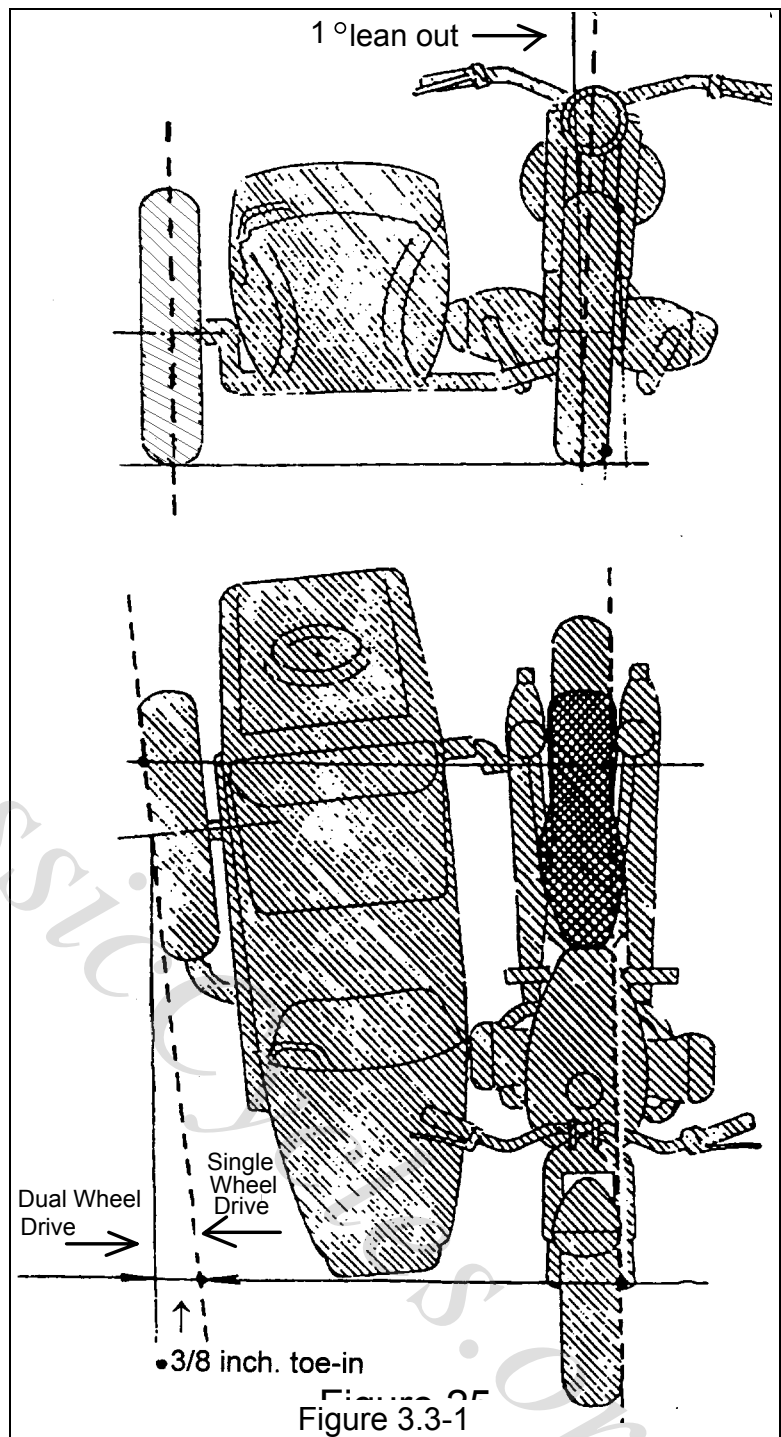

Road Testing

The true test of toe-in and lean-out adjustment is a road test, preferably on a smooth, straight, level, paved road with typical camber slanting off towards the right. At a steady speed of 40 mph, the motorcycle should not pull to either side while running at normal road speed. If the outfit pulls to the right, leanout should be increased to 2° or more, as required. If it pulls to the left, decrease the lean-out. The owner can be of best help by observing the handling characteristics, and reporting back at subsequent service opportunities.

NOTE: Weight of the driver and sidecar passenger affects leanout, so lean-out must be adjusted according to the typical load that will be carried on the motorcycle. For example, if a heavy load is usually carried in the sidecar a slightly larger lean out (say 2-3°) may be preferable.

3.4 Frame/Attachment

The sidecar frame is welded in one piece, except for the lower rear connector, the swing arm, and the rear fender support. Dents in the frame can be tolerated, but cracks should be repaired by arc welding and then repainted. When inspecting the sidecar frame, pay special attention to mounting tabs and flanges for attachment points and clamping bolts.

Collet Connectors

The collet connectors attaching the sidecar frame to the motorcycle frame are composed of two cast steel jaws drawn into a tapered tube by a long threaded bolt and a special winged nut. The jaws draw around the ball pins welded to the motorcycle frame. A cotter pin prevents the jaws from rotating as the bolt is screwed in or out.

NOTE: The OEM bolt has a comparatively small head diameter, which tends to round off and dimple in the end of the clamp tube. Metric bolts with a standard head diameter are available at hardware outlets in the thread diameter, length, and pitch suitable for this use. When replacing a collet clamp bolt, ensure that the overall length from bottom of head to threaded end is identical to the OEM bolt. Since this is a critical fastener, clamp bolts should be a minimum of grade 8. It is normal for the cotter pin to become curved in position as the motorcycle ball pins are drawn into the clamp tube.

If the collet clamp bolt is withdrawn from the assembly, the jaws can be removed for inspection. The winged nut is loose. When installing the bolt, it is necessary to reach inside the clamp and center the winged nut. The jaws and bolt threads should be well lubricated before installing, using a heavy waterproof lubricant such as boat trailer wheel bearing grease.

3.5 Suspension

The sidecar wheel is carried on a forked trailing link swing arm, supported by a hydraulic shock/spring. The swing arm pivots in rubber "silent block" bushings attached with long bolts ("pins"). No servicing or lubrication of the swing arm is required, except for the shock absorber. A conical rubber bumper is held in position by a cast bracket on the sidecar frame, to cushion the swing-arm in the extended position. The rubber bumper should be replaced if damaged or missing, to prevent metal-to-metal contact of the swing arm with the cast bracket.

Removing and reinstalling the sidecar swing arm ("wheel axle lever") single wheel drive models

To remove swing arm:

1. Jack up sidecar frame and remove wheel.
2. Undo brake tie-rod nut, pull out the rod and bushing.
3. Undo nuts and remove the pins at the swing arm pivots.
4. Undo the upper shock absorber nut.
5. Pull the swing arm back to allow removing the shock absorber from the upper pin.
6. Remove the swing arm complete with shock absorber and brake housing ("brake drum").

Reinstall the swing arm in reverse sequence, with the shock absorber and brake housing attached. Do not tighten up the bolts at the pivot brackets until the wheel has been reinstalled and the swing arm is in position to support the sidecar again.

CAUTION: It is necessary to compress the shock spring slightly to enable the swing arm to be pulled into position for attachment. Use care to avoid damaging the rubber bumper or the plastic shock protection boot.

Sidecar brake

The brake housing is centered on the sidecar axle, and torque reaction is contained by a slot on the aluminum housing locating on a tab welded on the swingarm. The brake is actuated via a rod, torque tube, and slotted lever, by the motorcycle rear brake pedal. The sidecar wheel is interchangeable with the other motorcycle wheels. Brake drums are integral with the wheel hubs.

CAUTION: When installing the sidecar wheel, ensure that there is a bearing thrust washer on the axle, between the housing and the inside wheel bearing. Failure to install a washer will allow the wheel hub to contact the brake shoes and/or the brake housing, with potential damage. Any steel washer of the correct size will suffice; thickness is not critical.

NOTE: If there is excessive play between the brake housing and torque tab, the brake will self-actuate when the sidecar rolls backwards. A metal shim can be fabricated to take up the play and prevent this reaction, if it the operator finds it an annoyance.

3.6 Sidecar Body

The sidecar body is easily removed from the frame for repairing either the body or sidecar frame.

1. Remove the bolts holding the two front clamps around the forward frame tube.
2. Remove the nuts from the two bolts extending up into the tunnel behind the seat.
3. Lift off the body, complete with seat and windshield.

The steel sidecar body can be repaired and painted by standard automotive body shop practices.

The trunk lid pivots on heavy-gauge steel straps with a riveted hinge. Check that the hinge is not fractured. The strap can be removed and repaired by welding, then repainted. Whenever the strap hinges are removed, the straps and body metal under the strap should be cleaned and painted to retard corrosion. The trunk lid latch is secured in the body by the welded-on handle.

When reinstalling the body on the sidecar frame, ensure that the rubber pads at the front clamps are in acceptable condition and that the rubber collars at the rear are flexible and the bolts well secured in the rubber.

3.7 Handling Differences Between Single Wheel Drive & Dual Wheel Drive

The driven sidecar wheel makes the Sportsman less likely to pull right when accelerating and left when decelerating. Turning left, especially when accelerating from a stop, is easier, since the driven sidecar wheel helps to pull the sidecar forward. Turning to the right from a stop is more difficult than the single wheel drive, since the driven sidecar wheel doesn't create a drag to the right when accelerating.

The sidecar wheel receives its torque via a differential in the final drive. About 30% of the power is transferred to the sidecar wheel on the ground. However, if the sidecar wheel leaves the ground, when power is being applied, most of the torque will transfer to the spinning sidecar wheel, and the motorcycle will lose forward thrust. If the sidecar wheel is kept in the air, it will spin up and the motorcycle will gradually roll to a stop even with the motorcycle engine running & in gear.

Warning: If the sidecar wheel is allowed to drop back to the ground while power is being applied, there is a potential for damage to the equipment as well as a sudden forward thrust on the motorcycle. Thus, it is *not recommended that the Sportsman sidecar wheel ever be lifted for more than a few seconds* during normal operation. Lifting of the Sidecar wheel should be limited to low speed training in a parking lot, with extreme care taken to reduce engine speed as soon as the sidecar wheel is lifted.

WARNING: OPERATORS SHOULD ALSO BE ADVISED NOT TO ATTEMPT SLIDING TURNS IN EITHER DIRECTION WITH THE SPORTSMAN. AT THE INSTANT WHEN EITHER DRIVE WHEEL LIFTS OFF THE SURFACE, TRACTION WILL BE INSTANTLY REGAINED ON THE OUTSIDE WHEEL, WITH THE VERY REAL POSSIBILITY OF A ROLLOVER. FOR THIS REASON, OPERATORS SHOULD BE COUNSELED TO LEAN BODY WEIGHT TO THE INSIDE OF ALL TURNS AND AVOID SLIDING THE TIRES. FOR MORE INFORMATION, REFER TO DRIVING THE URAL SIDECAR MOTORCYCLE.

Patrol

Since the sidecar wheel can be driven, the Patrol motorcycle handles differently from the standard Tourist (single wheel drive) motorcycle. It is important that owners and service personnel be aware of the differences.

Two wheel drive is not to be engaged on dry pavement. The two wheel drive mode is for loose gravel, snow or, wet surfaces only. It is important to understand that when engaged, the sidecar wheel and the rear motorcycle wheel are locked together, and will turn at the same speed. This will make turns impossible on dry pavement and may even result in breakage of the two wheel drive mechanism.

3.8 Driven Sidecar Wheel

The URAL Patrol final drive is not exactly the same as the Sportsman final drive. Unfortunately at this time, drawings of the Patrol final drive are not available. For this reason the following description of the Sportsman final drive is included in this manual to acquaint the owner with the general principals of the final drive mechanism.

The URAL IMZ - 8.107 "Sportsman" sidecar motorcycle has a driven sidecar wheel. (See Figure 7.8-1 & 7.8-2, General View). The sidecar wheel is driven via a shaft connected with the motorcycle final drive through universal joints. The final drive incorporates an asymmetrical differential that supplies approximately 70% of the torque to the motorcycle rear wheel and 30% of the torque to the sidecar wheel.

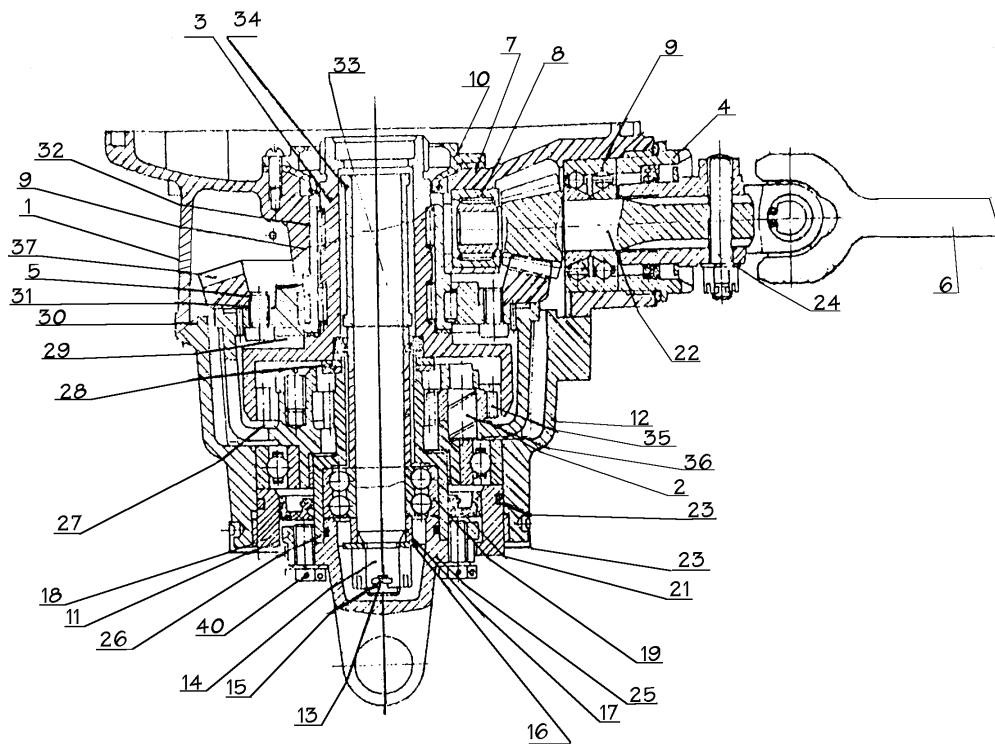

Figure 3.8-1. Main Drive Ä Sportsman Model

- | | | | |
|------------------------|----------------------------|---------------------------|------------------------|
| 1 - Gear case | 11 - Sun gear | 21 - Retainer | 31 - Roller |
| 2 - Differential body | 12 - Main drive case cover | 22 - Driving gear | 32 - Needle roller |
| 3 - Epicycle gear | 13 - Rear wheel axle | 23 - Seal | 33 - Spacer |
| 4 - Bearing nut | 14 - Axle nut | 24 - Bolt | 34 - Spacer |
| 5 - Hub | 15 - Splint | 25 - Propeller shaft fork | 35 - Satellite gear |
| 6 - Propeller shaft | 16 - Ring | 26 - Seal rings | 36 - Satellite pin |
| 7 - Case seal | 17 - Spacer | 27 - Driving gear | 37 - Driven gear crown |
| 8 - Needle bearing | 18 - Nut | 28 - Bronze spacer | 38 - Screw |
| 9 - Double-row bearing | 19 - Double-row bearing | 29 - Spacer | 39 - Ring |
| 10 - Seal cap | 20 - Sun gear seal | 30 - Gasket | 40 - Bolt |

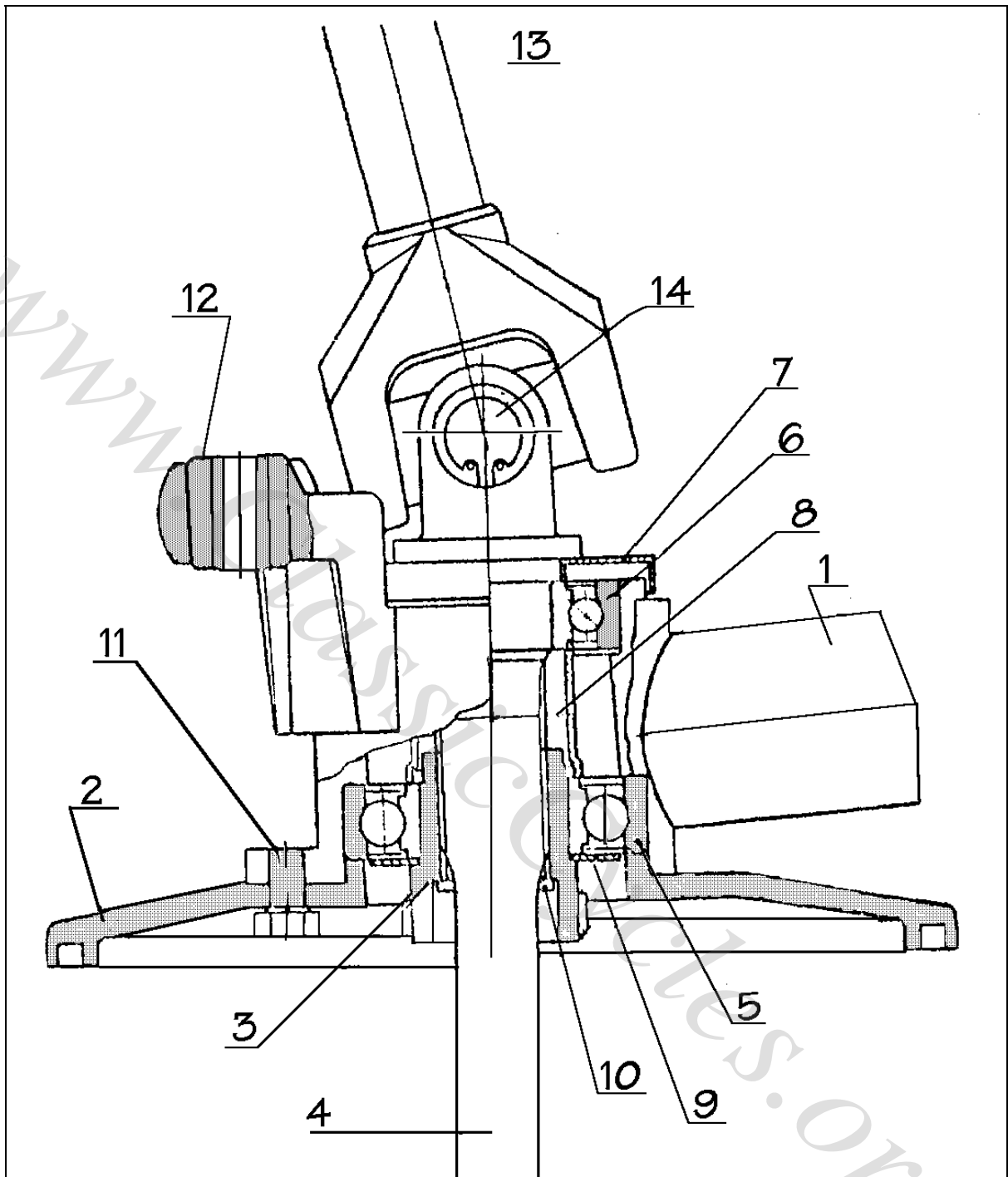

Figure 3.8-2. Sidecar Bearing Unit – Sportsman Model

- | | | |
|------------------------|---------------------|----------------------------------|
| 1 - Swinging arm | 6 - Ball bearing | 11 - Bolt |
| 2 - Braking drum cover | 7 - Protective ring | 12 - Shock absorber silent block |
| 3 - Slotted hub | 8 - Spacer | 13 - Propeller shaft |
| 4 - Sidecar pin | 9 - Ring | 14 - Universal joint |
| 5 - Ball bearing | 10 - Spacer ring | |

The Sportsman is different from the standard single-wheel-drive Tourist motorcycle (IMZ-8.103-40A) by changes to the following units:

- A. motorcycle final drive
- B. rear wheel swing arm
- C. sidecar swing arm and hub
- D. addition of sidecar drive shaft and universal joints
- E. sidecar chassis and fender
- F. sidecar brake tie rod

Sidecar Drive Maintenance

Check that the final drive, swing arm, propeller shaft fork and sun gear flange are bolted tightly, and that the universal joints do not have excessive play.

NOTE: The sidecar drive shaft may appear to be out of round as it rotates, indicating a bent shaft. The wobbling of the shaft is typically due to manufacturing tolerances, and does not impair performance. If the bent shaft is beyond normal tolerances, 2.5mm, it may be a result of an improper alignment between the motorcycle and sidecar. The rear bracket, ball clamp and sidecar prop must be correctly aligned with the motorcycle and sidecar frame to prevent future bending of the sidecar drive shaft.

After the first 2,500 kilometers, change the oil in the final drive gear case. Check the oil level every 2,500 kilometers. Oil level must not be lower than the oil gauge tip.

Grease the movable slot joint of the propeller shaft sufficiently every 5,000 kilometers. Do not over grease the slotted hub of the propeller shaft, which could hydraulically limit movement of the slotted shaft in the hub.

The shaft bearing of the sidecar wheel has a permanently lubricated bearing which should require no maintenance.

After every 5,000 kilometers grease the universal joint bearings, change the oil in the final drive gear case and fill with 80-90 hypoid gear oil.

Overhaul of Motorcycle Final Drive and Differential

To disassemble the main drive:

1. Remove the two bolts attaching the propeller shaft fork to the sun gear flange and move the fork in the direction of the sidecar giving access to the rear wheel axle nut.
2. Remove the wheel.
3. Remove the brake shoes.
4. Drain the oil from the main drive gear case.
5. Remove the collar and the cover.
6. Remove the gear case cover nuts and remove the cover together with the gasket.

Differential body and gears:

1. Remove the nut from the cover together with the sun gear and seal.
2. Tap lightly to remove the differential body with seal from the cover.
3. Remove the epicycle gear with two sets of rollers and seal and spacer from the case.
4. Remove the driven conical gear with the hub.
5. Remove the needle rollers from the splines in the hub in the gear case. Proceed further as described in the standard repair manual.

Assembling the main drive is effected in reversed order.

NOTE: Before tightening the nut in the case cover, the sun gear flange with seal and ball bearing must be installed. The bronze ring should be positioned onto the sun gear neck next after the steel ring. After putting the main drive together, check and adjust the side play of the conical gears by tightening or loosening the nut in the case cover. When side play of .01 to 0.3mm is achieved, fix the nut with the retainer.

Overhaul of the sidecar wheel shaft bearing.

1. Remove the fork of the propeller shaft from the flange of the sun gear at the main drive.
2. Support the sidecar and remove the wheel.
3. Remove the brake shoes.
4. Remove the wheel axle in the direction of the sidecar.
5. Remove the brake drum cover.
6. Press out the ball bearings together with the spacer and slotted hub.

3.9 Fender

The sidecar fender is a formed steel assembly, with a wiring trough on the inside to protect electrical wiring. Light assemblies bolt to the fender at the front and rear.

Light bulbs can be changed by removing the plastic lenses. Bulbs are standard automotive.

In the event changing a light bulb does not cure a non-functioning light, check the electrical connection plug to the motorcycle, then the wire connection at the back of the light assembly. It is necessary to remove the light bracket from the fender to access the wire connections.

CAUTION: When removing a light assembly, cover the fender to prevent accidental scratching of the paint by the sharp edges of the light bracket.

NOTE: When reinstalling a light assembly, ensure that the ground connections are clean and lubricated to help prevent corrosion. Petroleum jelly can be used on electrical contacts to control rust.

3.10 Upholstery

The sidecar seat components are a plywood base covered by springs, cotton batting, and a vinyl-type fabric that is folded over and secured to the base. The seat and back are removable.

When installing the seat, place the seat back in position first, holding it up in position so that the metal straps on the back are behind the bulkhead. The OEM floor mat is heavy ribbed rubber. When replacing the seat cushion, ensure that the hole in the rubber is positioned over the hole where the seat tab enters the body. With the rear of the seat held up, insert the seat tab through the floor mat and the hole in the floor. Then push the rear of the seat cushion down until it slides underneath the bottom of the seat back.

CAUTION: When handling seat cushion or seat back, take care to avoid placing the components on painted surfaces which could be scratched by the mounting tabs. Also, do not allow upholstery to touch any rubber items, this will permanently stain the vinyl.

Engine

4.1 Description and General Specifications

The motorcycle is equipped with a twin cylinder overhead valve four stroke carbureted air-cooled engine. The horizontally opposed cylinder arrangement provides excellent engine balance, as well as better air cooling of cylinders and heads. Overhead valves are actuated by pushrods.

The valve timing gear (Fig. 4.3-1) controls combustion mixture into the cylinders and waste gas exhausted into the atmosphere. The intake and the exhaust valves are not interchangeable. The camshaft rests above the crankshaft on two bearings inside the engine crankcase; a front ball bearing, and a rear bronze blind bushing. Camshaft drive is by gear from the front of the crankshaft. Tappets ride in guide bushings, actuating pushrods through sealed tubes in the cylinder. Rocker arms mounted on the cylinder heads push directly on the valve stems. Valve clearance is adjusted via screws in the rocker arms.

The engine cylinders (8) (see Fig. 4.1-2) are identical in design and interchangeable. A gasket is fitted between the cylinder and the crankcase to control oil seepage.

Pistons have three milled grooves for the piston rings, which have straight locks. The piston is coupled to the connecting rod by means of a floating piston pin with circlips.

The engine crankshaft is a pressed assembly made up of two crank portions with counterweights and pressed-in crankpins. Connecting rods have solid lower ends with roller bearings. The crankshaft is carried in two large diameter ball bearings.

Crankcase

The crankcase accommodates the cylinders, the timing gear and auxiliary mechanisms, and also serves as an oil reservoir. Oil Filter (22) mounted in the timing gear cover is stopped with a plug (24) incorporating a bypass valve. The crankcase has forced ventilation via a breather (15) located in the central opening of the timing gear cover. As the pistons move away from the crank, the vent duct is overlapped, the crankcase interior is cut off from the atmosphere and a vacuum occurs. A constant vacuum in the crankcase helps prevent oil loss though the seals when the engine is running. The crankcase ventilation system is routed to the air cleaner.

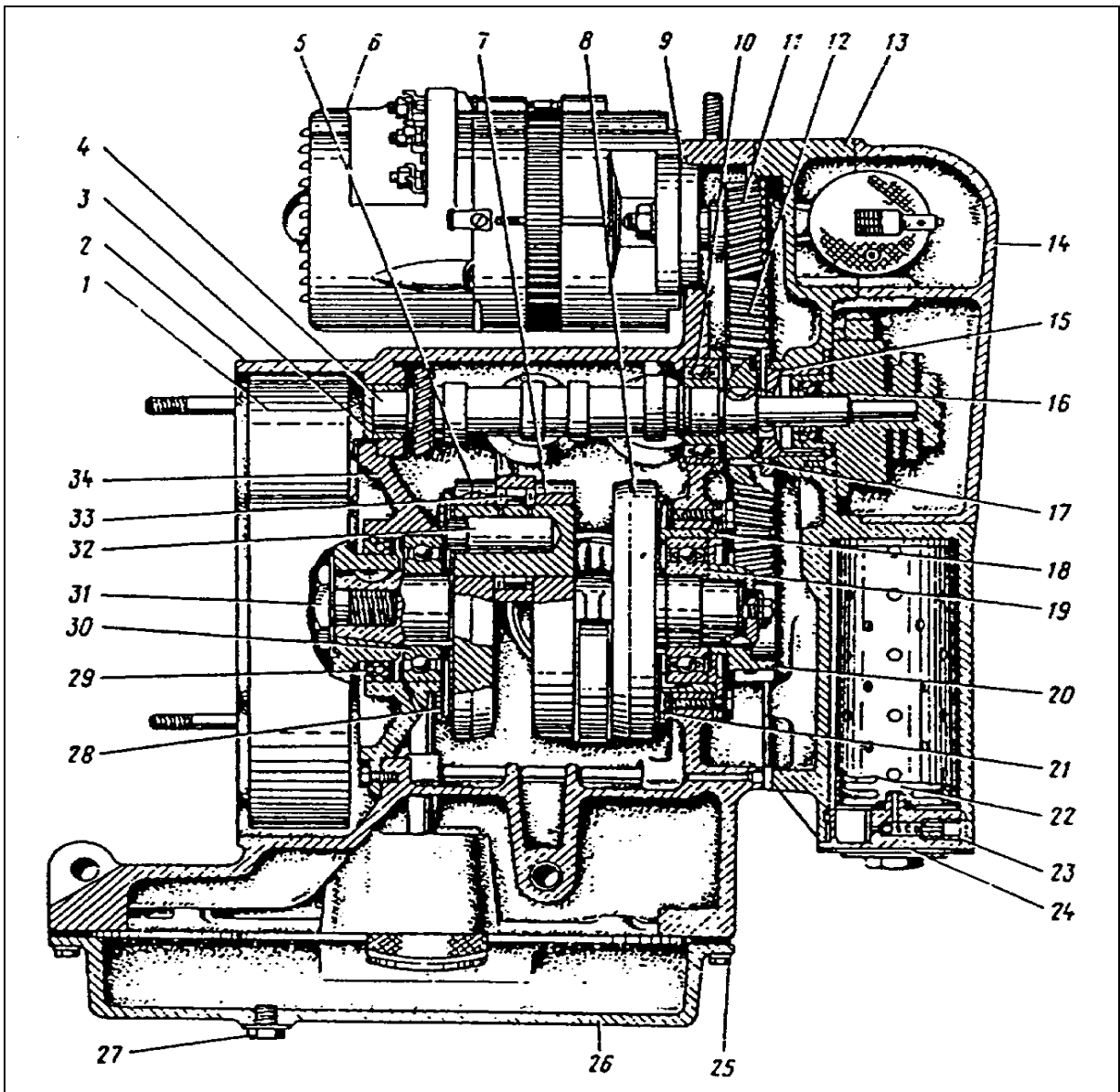

Figure 4.1-1. Engine (longitudinal section)

- | | | |
|---------------------------------|---------------------------------|------------------------------|
| 1 - Flywheel | 12 - Camshaft gear | 23 - Packing ring |
| 2 - Crankcase | 13 - Timing gear cover | 24 - Oil filter plug |
| 3 - Camshaft bushing | 14 - Front cover of crankcase | 25 - Sump bolt |
| 4 - Camshaft | 15 - Breather | 26 - Sump |
| 5 - Rear journal of crankshaft | 16 - Seal | 27 - Drain hole plug |
| 6 - Starter/Generator | 17 - Breather tenon | 28 - Oil trap |
| 7 - Crankshaft cheek | 18 - Front ball bearing housing | 29 - Seal |
| 8 - Front journal of crankshaft | 19 - Ball bearing | 30 - Ball bearing |
| 9 - Generator gasket | 20 - Timing pinion | 31 - Flywheel fastening bolt |
| 10 - Camshaft bearing | 21 - Oil trap | 32 - Crank pin |
| 11 - Generator gear | 22 - Oil filter | 33 - Roller bearing |
| | | 34 - Rear bearing housing |

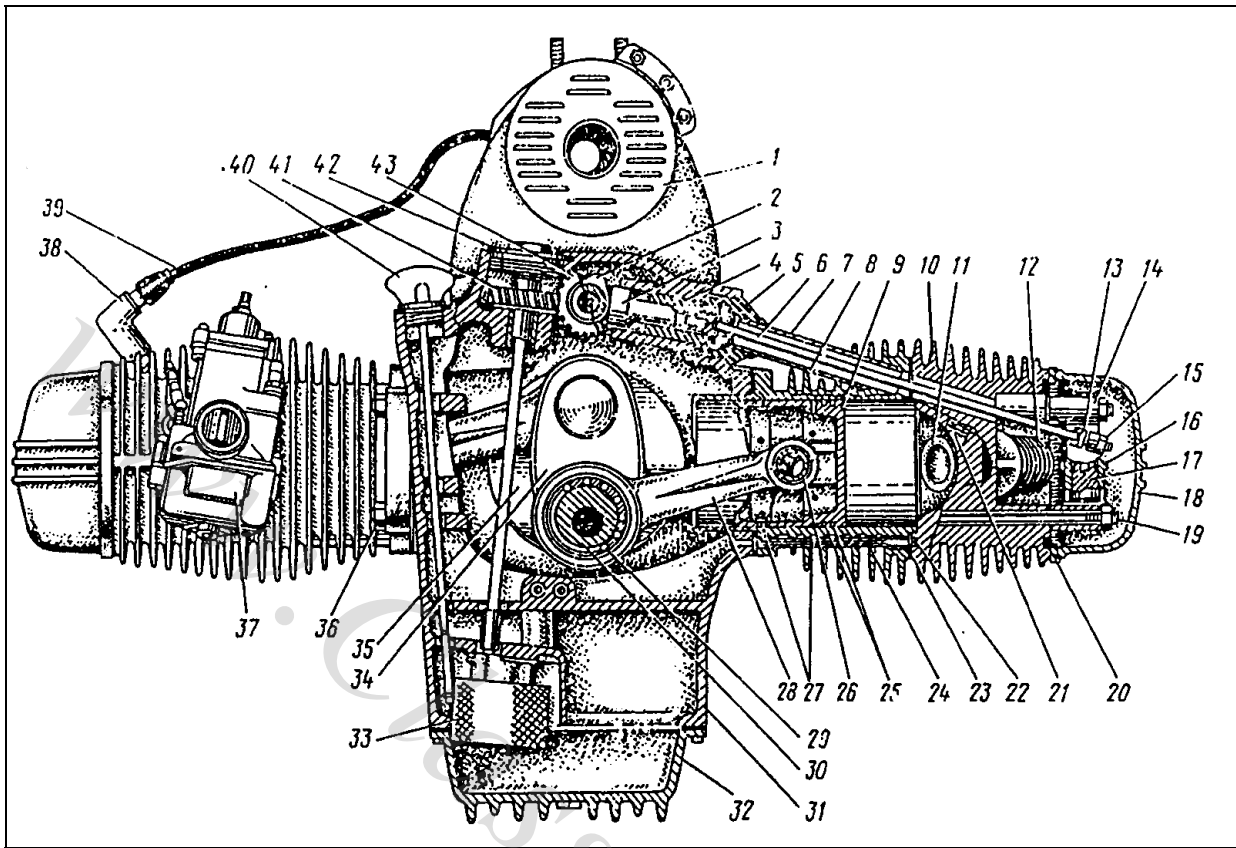

Figure 4.1-2. Engine (cross section)

- | | | |
|------------------------|--|--------------------------------|
| 1 - Starter/Generator | 15 - Adjusting bolt locknut | 29 - Roller bearing |
| 2 - Camshaft | 16 - Rocking arm | 30 - Crankpin |
| 3 - Tappet | 17 - Rockshaft | 31 - Crankcase |
| 4 - Tappet guide | 18 - Cylinder head cap | 32 - Sump |
| 5 - Sealing cap | 19 - Cylinder head stud | 33 - Oil pump |
| 6 - Push rod | 20 - Gasket | 34 - Crankshaft cheek |
| 7 - Push rod tube | 21 - Ignition plug | 35 - Oil trap |
| 8 - Cylinder | 22 - Duct for oil out of cylinder head | 36 - Cylinder fastening nut |
| 9 - Piston | 23 - Gasket | 37 - Carburetor |
| 10 - Cylinder head | 24 - Oil drain tube of cylinder | 38 - Spark plug tip |
| 11 - Valve | 25 - Compression rings | 39 - H.V. wire |
| 12 - Valve spring | 26 - Piston pin | 40 - Filler plug with dipstick |
| 13 - Adjusting bolt | 27 - Oil rings | 41 - Oil pump drive gear |
| 14 - Rockshaft bracket | 28 - Connecting rod | 42 - Oil pump drive plug |

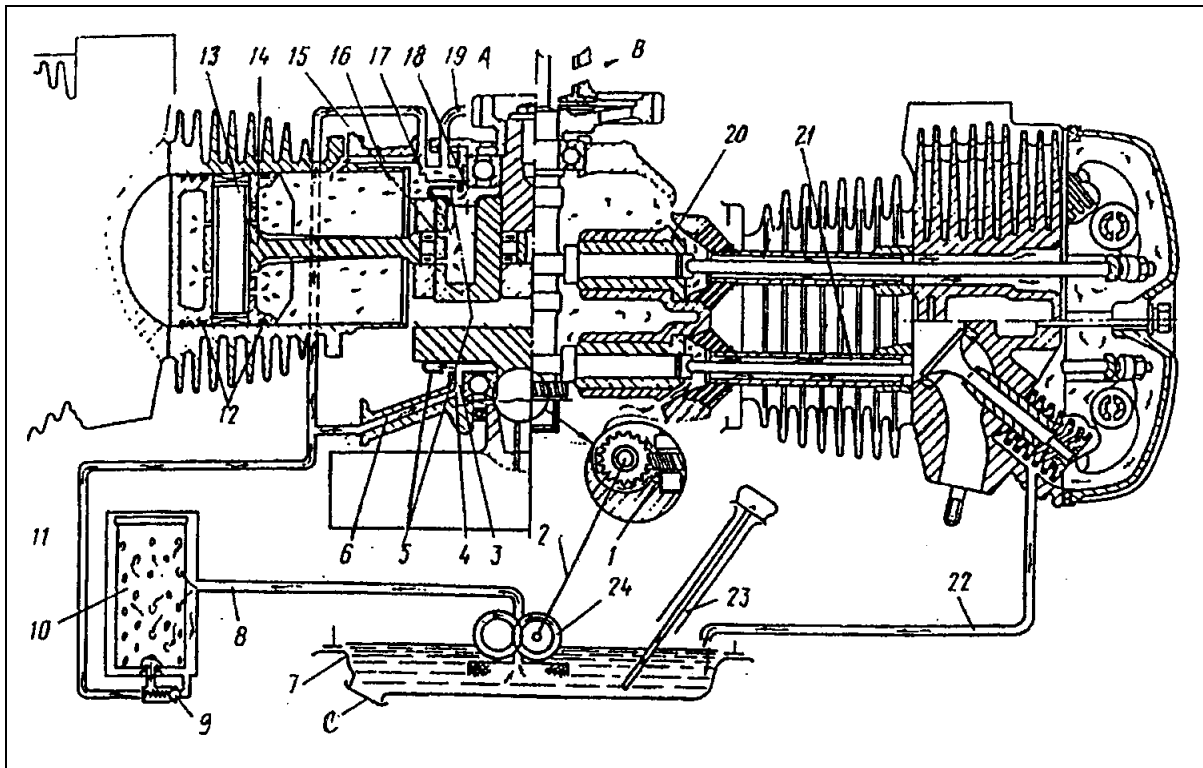

Figure 4.1-3. Engine Lubrication System

- | | |
|--|---|
| 1 - Duct for oil flow to rear bearing | 15 - Holes in crank pin for lubrication of connecting rod big end bearing |
| 2 - Connecting bar and oil pump drive gear | 16 - Oil supply duct to left-hand cylinder |
| 3 - Duct in rear bearing housing for oil flow | 17 - Inner cavity of crank pin |
| 4 - Calibrated hole for oil flow | 18 - Oil duct for lubrication of friction parts in cylinder head |
| 5 - Crank shaft oil traps | 19 - Tube for lubrication of timing gears |
| 6 - Vertical duct for oil flow into rear bearing housing | 20 - Oil duct for lubrication of friction parts in cylinder head |
| 7 - Crankcase sump | 21 - Inner cavity of push rod tube for oil flow |
| 8 - Oil duct to oil filter | 22 - Oil drain duct out of cylinder head |
| 9 - By-pass valve | 23 - Filler plug with dipstick |
| 10 - Oil filter | 24 - Oil pump gear |
| 11 - Main oil line | A - Lubrication of valve timing gears |
| 12 - Piston oil rings | B - Gas escape out of engine crankcase |
| 13 - Holes in connecting rod small end for lubrication of piston pin | C - Oil drain out of crankcase sump |
| 14 - Holes in piston bosses for lubrication of piston pin | |

The engine has both splash and pressure lubrication. Critical parts are pressure lubricated by a mechanical oil pump. (Figure 4.3-1) A full-flow replaceable oil filter is provided in the lubrication system to prolong the engine service life. The crankcase serves as the oil reservoir for the engine. The single-stage oil gear pump (24) is driven from the camshaft through a gear and connecting bar (2).

Oil is primed into the engine crankcase through the hole in the left-hand side of the engine block, normally capped with the dipstick (23). The dipstick has two grooves showing the upper and lower oil level limits. Oil level is checked with the dipstick not screwed in.

www.ClassicCycles.org

4.2 Repair Information and Service Limits

The repair of components which can be removed without removing the engine is covered in the appropriate sections. For inspecting or repairing internal engine components such as the camshaft or crankshaft, it is necessary to remove the engine from the frame.

To remove the engine together with the gearbox, proceed as follows:

1. Set the motorcycle on the stand.
2. Disconnect the sidecar.
3. Remove the fuel tank, mufflers and exhaust pipes, footrests, air cleaner, and battery.
4. Disconnect the wires leading to the horn and the ignition/coil.
5. Remove the horn.
6. Unscrew spark plugs and temporarily plug the holes.
7. Place the high-voltage wires with lugs under the alternator.
8. Disconnect the adjusting bolts of the clutch control cable from the clutch control lever at the gearbox and from the clutch cable armor stop.
9. Slacken off the bolt fastening the speedometer drive bushing, remove the drive and shift it aside, then reinstall the bolt.
10. Disconnect the wire from the neutral switch.
11. Slacken off the engine upper fastening nuts and those of the stand bracket, remove the bracket and the engine fastening plate.
12. Slacken off the nuts of the engine lower fastening studs.
13. Remove the spring of the rear brake lever.
14. Place a support under the engine sump and remove the engine fastening studs.
15. Move the engine together with the gearbox forward, disengage the flexible joint flange from the rubber coupling of the propeller shaft.
16. Remove the support from under the engine sump and tilt the engine to the left so that the alternator is positioned to the left of the frame tube, then lift the engine out through the left-hand side of the frame.

CAUTION: It is advisable that two persons take the engine with gearbox out of the frame.

Having removed the assembly, set it up on a mounting stand.

Reverse the sequence of operations when reinstalling the engine and gearbox in the motorcycle frame.

4.3 Cylinder Heads and Valves

Valves are carried in the cylinder head by replaceable guides. Export model URALs have special cast iron guides. Exhaust valves and intake valves are of different diameter.

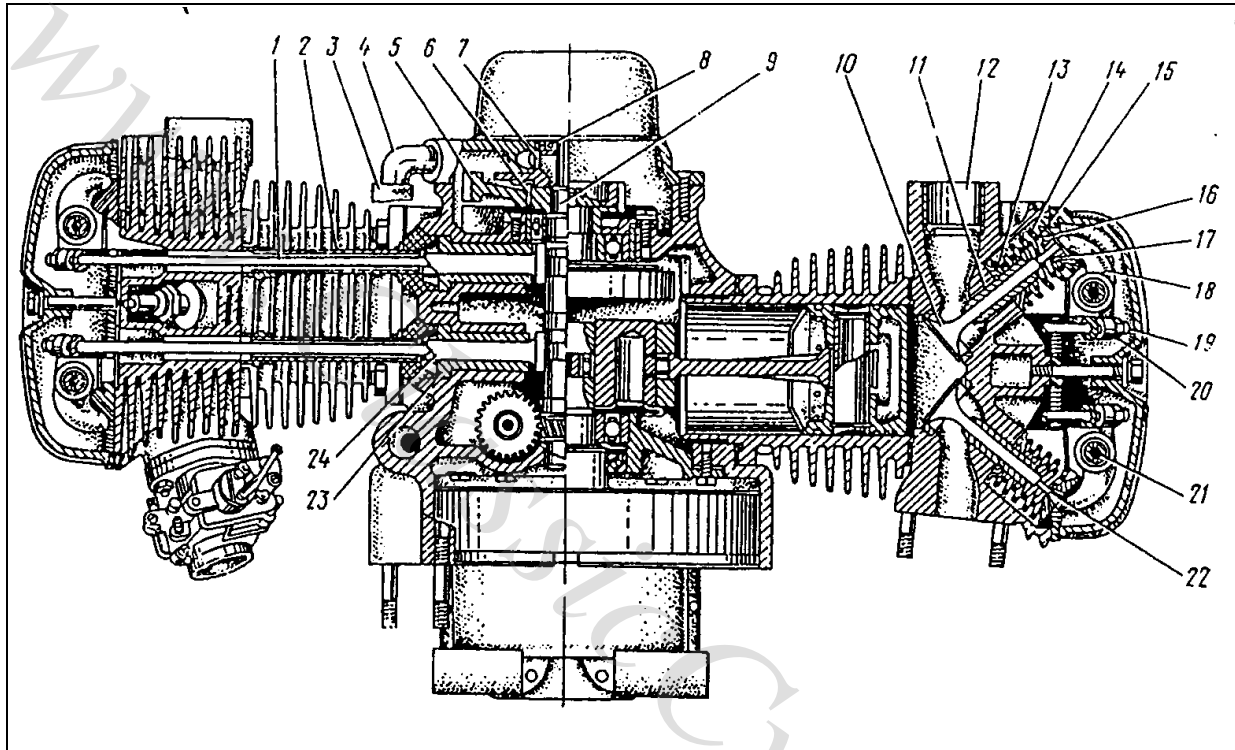

Figure 4.3-1. Engine Valve Timing Gear

- | | |
|----------------------|-----------------------------|
| 1 - Push rod | 13 - Lower retainer |
| 2 - Push rod housing | 14 - Outer valve spring |
| 3 - Hose | 15 - Inner valve spring |
| 4 - Breather pipe | 16 - Upper retainer |
| 5 - Camshaft gear | 17 - Valve block |
| 6 - Breather tenon | 18 - Rocker arm |
| 7 - Breather | 19 - Adjusting bolt |
| 8 - Seal | 20 - Adjusting bolt locknut |
| 9 - Camshaft | 21 - Rockshaft |
| 10 - Exhaust valve | 22 - Intake valve |
| 11 - Valve guide | 23 - Tappet guide |
| 12 - Exhaust branch | 24 - Tappet |

Valve Adjustment

It is very important to adjust the valves properly. Valves are adjusted to provide the correct clearance with a cold engine. The clearance should be 0.002 in / 0.05 mm. In service, clearance will change due to bedding-in of parts. It is important to re-adjust the clearances after running in, following grinding or partial disassembly of the valve mechanism.

Valve adjusting procedure (Figure 4.3-1): Remove spark plugs. Place a pan under the cylinder head, take off the valve cover ("head cap") and drain off accumulated oil. Then turn the crankshaft slowly, using the kick lever. Just when the intake valve (22) begins to close, set the clearance for the exhaust valve (10) and at the time the exhaust valve begins to open, set the clearance for the intake valve. Check the clearance between the larger end of the rocker arm and the valve stem. If the clearance is not correct, slacken off locknut and by turning the adjusting bolt (19) in or out, set the required clearance with a feeler gauge. Lock the adjusting bolt with the locknut (20) and check the clearance again. In the course of running-in, check after 500 km and as required, but at least once every 2,500 km. Readjust clearances on the cold engine only.

The following symptoms indicate valve problems:

- loss of compression in the cylinder
- drop in engine power
- increase in fuel consumption
- difficulties in starting the engine
- increased noises from the valve train

Removing and Reinstalling the Cylinder Head

(the engine may be left on the motorcycle)

Required tools and fixtures:

- Pan for draining oil from the cylinder head cover
- 0.02 in. / 0.05 mm feeler gauge
- Crank handle 345-316-3

NOTE: If it is necessary to remove the right-hand cylinder head with the engine still in the frame, first detach the sidecar.

To remove the cylinder head from the engine:

1. Remove the muffler and exhaust pipe, the spark plug lead and spark plug, and the fuel hose to the carburetor. Make sure that the fuel valve is shut off and that there are no fuel leaks.
2. Disconnect the carburetor intake branch and carburetor.
3. Place a pan under the cylinder head to catch oil drips, and remove the cylinder head cover.

4. Set the crankshaft at TDC (top dead center) so that both valves of the cylinder are closed, using either the kickstarter to turn the crankshaft, or crank handle tool 345-316-3 if the gearbox has been removed.
5. Undo the fastening nuts and remove the rocker arms together with rockershaft brackets.
6. Remove the push rods.
7. Remove the cylinder head and its gasket.

NOTE: When removing the cylinder heads, especially when removing both heads, tag or separate the rocker arms and push rods to ensure the same parts are installed in the same positions when reassembling.

Decarbonize the combustion chamber, wash and inspect the head.

To check the valves for proper seating, flood the intake duct of the cylinder head with kerosene or solvent and watch for leaking around the valve seat. Repeat the procedure with the exhaust valve. Absence of leaks is ample proof of proper seating of the valve. If necessary, remove the valves, take measurements and repair.

Repairing the Cylinder Head

Required tools and fixtures are:

- Tool 345-553 for removing valve springs
- Indicator with stand
- Inside caliper with 8 mm indicator head
- Micrometer from 0 to 25 mm
- Mandrel 345-047-3 for pressing in and out the valve guide bushing
- Reamer 055-150-3, 8 mm diameter, for reaming the valve guide bushing
- Gauge 403-747 for checking straightness of hole in valve guide bushing
- Puller with set of tools 345-326-3, 345-570-3 and 061-100-3 for removing valve seat
- Mandrel for pressing in the valve seat
- Tool 345-332-3 to rotate the valve while grinding
- Set of cutters with mandrel 345-558, 032-106-6, 032-132 for machining the valve seat chamfer

Inspect the cylinder head carefully, to make sure that there is no damage, cracks, burned valves or stripped threads; also check that the base of the cylinder head is true and that of the carburetor is level. In order to inspect the condition and wear of valves, valve guide springs, and valve seats, remove the valves.

To remove the valves:

1. Fasten the cylinder head on the tool 345-553, fit the lever on the stud securing the cylinder head cover and secure the lever.
2. Turning the lever, compress the valve springs and remove the locking keys (Fig. 4.3-2).

3. Turn the lever round the stud and remove the valve keys from the other valve.
4. Remove the top valve spring retainers, the springs and the valve spring seats.
5. Free the cylinder head from the tool and remove the valves.
6. Clean the removed parts of carbon, tar, etc., wash them and inspect.

NOTE: A "C-type" valve spring compressor may be used as an alternative to the URAL tool.

While inspecting the valves, check:

- Clearance between the valve stem and the guide
- Wear of the valve stem
- Condition of the valve head seating chamfer

While inspecting the cylinder head, check:

- Wear of the valve guide
- Wear of the valve seat
- Check wear at two locations: Direction of valve pressure (rocker arm movement) fore and aft and 90° opposite.

Table 4.3-1. Resilience of the Valve Springs and Free Height

Part No.	Part Name	Diameter of wire (mm)	Length of spring in free state, (mm)
6201419-01	<i>outer valve spring</i>	4	43
<i>Resilience of spring:</i> When compressed to 34 mm, $P=145..168\text{ N (14.8...17.2 kgf)}$; When compressed to 35.75 mm, $P=296...343\text{ N (12.15...25.85 kgf)}$			
6201420-01	<i>valve spring, inner</i>	3	39
<i>Resilience of spring:</i> When compressed to 30.5 mm, $P=96.5..111\text{ N (14.8...17.2 kgf)}$; When compressed to 35.75 mm, $P=296...343\text{ N (12.15...25.85 kgf)}$			

Remember that the compression, power, and fuel consumption of the engine depends to a great extent on the condition and correct machining of the valves, guides, and seats. If the seats and heads of the valves are fouled with carbon but their wear is insignificant, while valve contact area is concentric and within 1.5 to 1.8 mm, proceed only with cleaning the valve and touching up the seat chamfer.

In case of considerable deformation, burn spots or cracks on valve head, replace the valve. If the valve has only minor defects such as pits or burn spots on the seating area, the valve can be ground, providing there is sufficient metal left. Use a valve refacing

machine with a centering chuck to fit the valve stem for the purpose. In grinding take off only as much material as needed to remedy the defect. The cylindrical bead on the edge of the valve head should be no thinner than 1 mm.

Measure the side play between the valve stem and the guide with the help of an indicator, the feeler pin of which should rest against the valve stem end with the valve moved 3/16 inch / 4 mm off the seat (Fig. 4.3-3).

Guide wear should not exceed .010 inch / 0.25 mm. If there is excessive clearance, measure the valve stem and determine whether the wear is in the valve stem, the guide, or both. For this purpose measure the diameter of the valve stem and the guide bushing at a distance of 1/4 inch / 5 mm inside the upper and lower edges of working surfaces. If the wear of the valve stem exceeds .005 inch / 0.12 mm, replace the valve; if the wear of the guide bushing exceeds .006 inch / 0.15 mm replace the guide.

Valve Guide Replacement

1. Decarbonize the guide (especially its neck).
2. Fasten the cylinder head in the vice, insert mandrel 345-047-3 and press out the valve guide bushing. The head may be heated to facilitate guide removal.
3. Check the condition of the hole into which the valve guide is to be fitted. When you are ready to install the new guide, heat the head to 390°F/200°C. Place the cold valve guide on the mandrel 345-047-3, and quickly press the guide in place. Deck height of the valve guide should be 20 mm measured from spring washer land on head, to top of guide (without spring washer in place). Guide should be enough of a press fit in the head casting that the guide does not fall out even when the head is hot.

WARNING: Take precautions to avoid burns while handling the heated cylinder head.

After the head has been allowed to cool, check that the guide is firmly retained in the casting, then ream the guide to 8.00- 8.03 mm diameter, using reamer 055-150-3. Check the hole for straightness with the help of 7.98 mm gauge 403-747.

After installing a new valve guide, check the valve seat chamfer concentricity, and, if not concentric, grind or machine the valve seat chamfer. Check valve-to-seat alignment by coating the valve seat chamfer with a thin layer of Pal ("Prussian blue") and fit the valve, turning it while pressing the valve head against the seat. Valve fit is considered normal, when the paint fillet formed on the valve head is positioned in the center of the chamfer and its width is within .060 to .070 inch / 1.5 to 1.8 mm.

If necessary, correct the seat chamfer, using a grinding stone or cutters of 30 and 45 degrees. (cutters 032-106-6 032-132 with mandrel 345-558) valve contact area is at 45 degrees, inside chamfer is at 60 degrees (Fig. 4.3-4).

If the valve seat cannot be restored to correct dimensions by grinding or is loose or damaged, change the valve seat as follows.

Using the set of tools 345-326-3, 345-570-3 and 061-10 thread the valve seat bore, heat the cylinder head to 390°F/200°C, screw in the puller and press out the valve seat (Fig. 24).

Reheat the cylinder head and immediately press in the new valve seat using the mandrel. After the head has cooled, machine the valve seat to the correct dimensions.

Valve sealing can be checked by installing them and, while pressing the valve heads to the seats, pouring kerosene alternately into the intake and exhaust ducts of the cylinder head. There should be no detectable seepage of kerosene for at least one minute. If necessary, the valves can be lapped to achieve a tighter seal.

Lapping-in the valve to cylinder head seat:

Fit a spring around the valve stem between the valve head and guide to help lift the valve off the seat approximately 3 to 6 mm.

1. Coat the valve head face with a thin film of fine grinding

compound, insert the valve with the hold-off spring into the valve guide and fit tool 345-332-3 for turning the valve on the valve stem end.

2. Rotate the valve in both directions, pressing it from time to time to the seat.

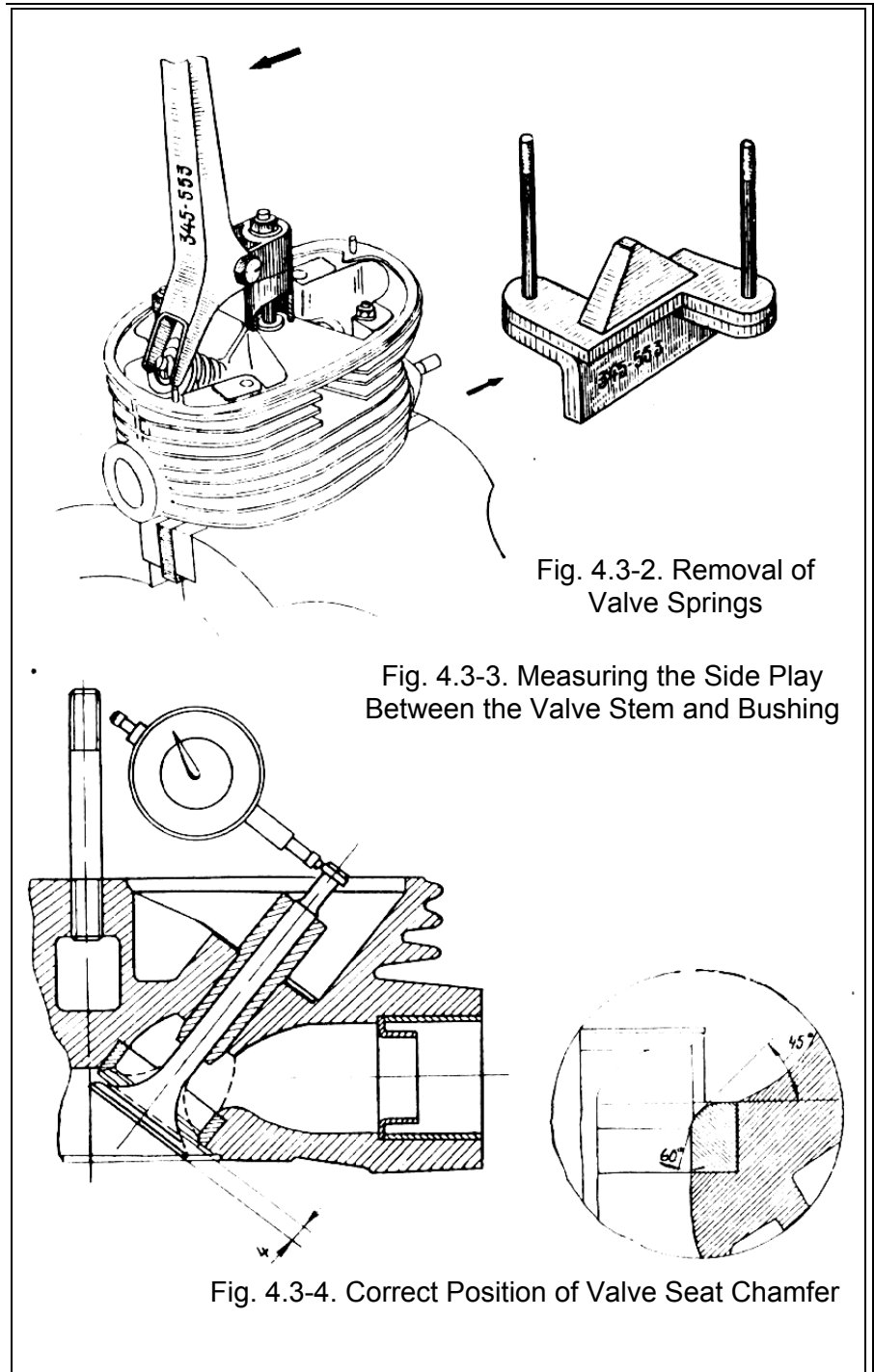

3. Remove the minimum amount of metal from the working chamfers to prolong the service life of the valve. Towards the end of the lapping process reduce the amount of grinding compound and then lap with clean oil only.
4. Once a uniform dull-gray color (with no black spots) is obtained on the contact areas of the valve and the seat, the lapping is considered satisfactory.
5. After the machining and lapping, wash the valves, seats, guides, and the cylinder head combustion chamber with detergent and hot water, to remove all the traces of the grinding compound, then wipe dry.

Having completed the checks, measurements and repairs, reinstall the valves. Coat the valve stems with assembly lubricant prior to fitting them in place.

Repairing Valve Rocker Arms

Required tools are:

- micrometer up to 1 inch / 25 mm
- inside caliper with measuring range of .35 to .75 inch with .0005 increments / 10 to 18 mm and 0.01 mm increments

Before removing the rocker arms and support blocks, mark or tag them to ensure that the parts are replaced in the same positions.

To dismantle, press the rocker shaft off the support brackets.

Clean the parts, inspect, and take necessary measurements. Visually inspect the rockshaft, rocker arms, support brackets and spring washers for cracks, dents, or scores. Check that the valve stem contact area of the rocker arm is not worn flat. If there is any detectable play in the rocker assemblies, measure wear of rockshaft and the bores of the rocking arms. If the wear of shafts or bores in the rocker arms exceeds .0025 inch / 0.07 mm, replace the worn parts.

If the bronze bushings are worn, they can be replaced. Press in new bushings, and ream to .590 to .592 inch / 15.000 to 15.027 mm.

Reassemble the rocker arms as follows:

NOTE: The rocker shafts have an oil supply hole in one end only.

1. Press the rocker arm into the support bracket, positioning the shaft end with no oil hole into the lower bracket, and the machined side of the bracket facing towards the shaft. When pressing-in, position the support bracket as shown in Fig.4.3-5. Lubricate the rocker arm and shaft with motor oil.

Fit on the rocker arm and spring washer (dimple side towards upper support bracket) and press on the upper bracket, aligning the recess in the rockshaft with the hole in the bracket. Position the brackets and rocker arms as shown in Figures 4.3-5 and 4.3-6.

If the adjusting bolt has been removed from a rocker arm, screw it back in to the limit, then fit a lock-nut.

Push Rods

Inspect push rods for wear and straightness. If a pushrod is bent or the ends are worn, replace it. The total length of the push rod should be 9.18 inch / 233 mm within .040 inch / 1 mm.

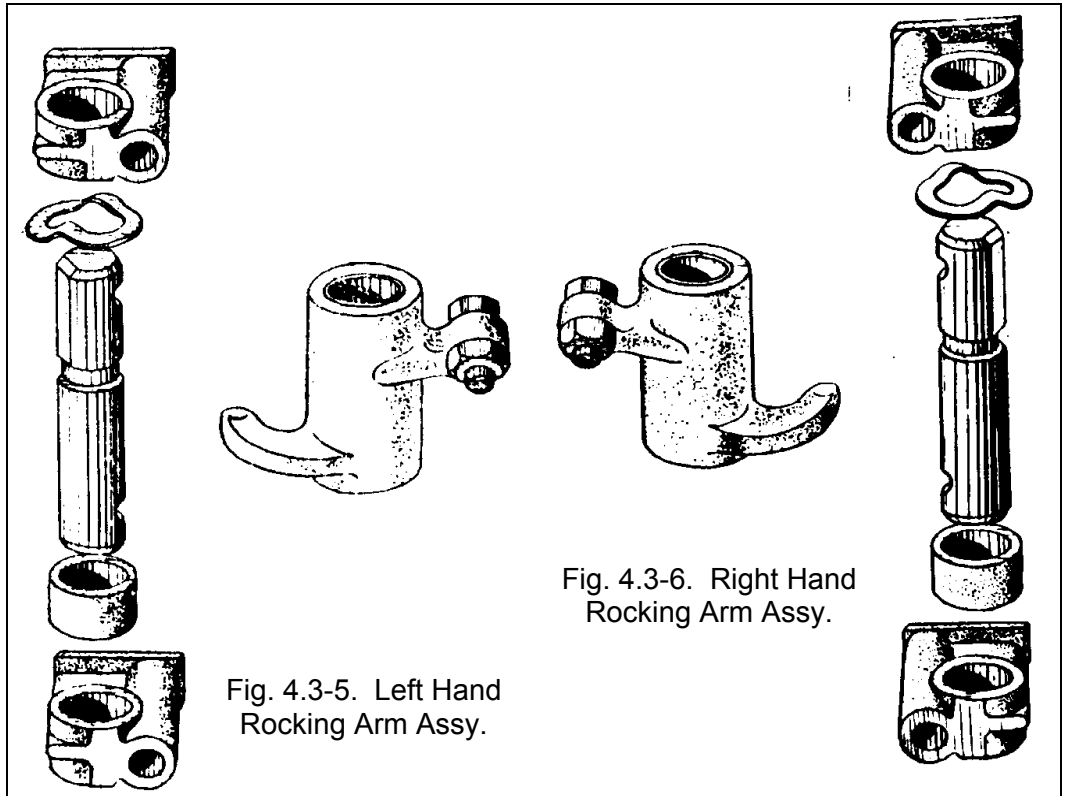

Fig. 4.3-5. Left Hand Rocking Arm Assy.

Fig. 4.3-6. Right Hand Rocking Arm Assy.

Check push rod straightness using a .008 inch / 0.2 mm feeler and a flat plate. The feeler should have constant resistance between the push rod and flat plate as the pushrod is rotated.

Installation of cylinder head (cylinders and pistons already installed)

CAUTION: Remember that incorrect installation of a push rod can lead to bent valves. Before installing the cylinder head, rotate the engine to TDC so the pushrods are not attempting to compress the valves. Ensure that there is clearance between the rocker arms and valves before torquing the head.

If there is no push rod clearance, check that the push rod is in place in the tappet cap, turn the adjusting bolt in further, and ensure that the crankshaft is at TDC with the tappet completely lowered. If the camshaft has been serviced, check that the camshaft is timed correctly.

Tighten up the nuts fastening the brackets of the rockshaft in a diagonal sequence in three passes, reaching final torque on the last pass.

Final cylinder head tightening torque is 23 foot/pounds. / 33 Nm.

With the head torqued, and piston at TDC, adjust valve clearance by inserting a feeler gauge between valve stem and rocker arm (Fig. 4.3-7). Valve clearance of both valves is

.002 in. / 0.05 mm. Lock the clearance adjusting screw with the lock nut, rotate the engine through at least one revolution, and confirm correct clearance.

Before installing the valve cover in place, lubricate the rockshaft through the central oil holes in the shaft.

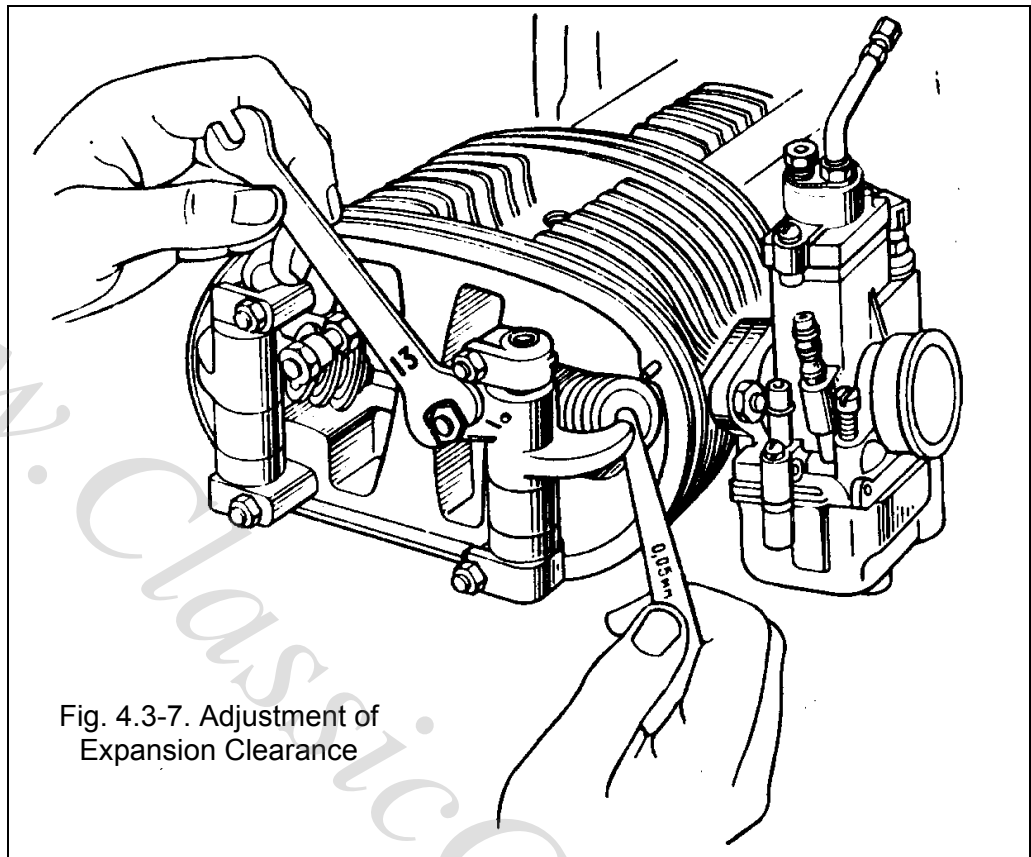

Fig. 4.3-7. Adjustment of Expansion Clearance

4.4 Cylinders and Pistons

Removing Cylinders

(The engine may be left on the motorcycle with the cylinder heads removed.)

Required tools:

- crank handle tool 345-316-3 for turning the crankshaft
- clamping ring tool 345-037 for compressing the piston rings when fitting the cylinder

To remove the cylinder:

1. Set the piston at TDC (top dead center).
2. Turn off the cylinder fastening nuts and carefully ease the cylinder away from the block by slightly rocking it.
3. If the bottom gasket is damaged, remove it and replace.

Having removed the cylinder, decarbonize it, wash, inspect and measure the cylinder bore.

Cylinder Inspection and Repair

The required gauge is inside caliper with indicator head with the measuring range of 3.0 to 4.0 inches / 80 to 100 mm and divisions of at least .0005 inch / 0.01 mm.

Before inspecting and measuring, decarbonize the cylinder (top portion) and wash it. Check for cracks, especially at the neck and mounting flange, also for tight fit of oil draining tube and the tappet push rod tubes. Visually inspect for scores on the cylinder bore.

NOTE: If there is visible damage to the cylinder bore, such as deep scores, obvious ring ridge or warpage, consider replacing the entire cylinder / piston assembly.

If the cylinder appears to be serviceable, measure the bore with the inside caliper at several different angles and depths. For example, three different depths measured both in line with the piston pin and at 90 degrees.

Out-of-round and taper are tolerated within 0.002 inch / 0.05 mm, the cylinder face axis should be square to the thrust surface of the cylinder flange within 0.002 inch per 4 inches of length (0.06 mm per 100 mm of length). If the cylinder face is out-of-round or tapered in excess of 0.002 inch / 0.05 mm, or wear exceeds 0.006 inch / 0.15 mm, the cylinder should be replaced or rebored to the nearest oversize piston (refer to Table 4.4-1). After reboring, the cylinder face should be honed in a cross-hatch pattern. After honing, use a brush to wash the cylinder face with a concentrated solution of detergent in water, then wipe dry and lubricate with light oil. Do not use solvent alone to wash the cylinder face, as petroleum solvents may not remove fine particles of metal and abrasive dust off the cylinder walls.

Table 4.4-1. Repair Sizes of Pistons and Corresponding Sizes of Cylinders, mm

Repair Size of piston	No. of Piston Skirt	Stamped index	Corresponding cylinder size, mm
6601237-P1	78.11...78.12	A1	78.20...78.21
	78.12...78.13	B1	78.21...78.22
	78.13...78.14	C1	78.22...78.23
6601237-P2	78.41...78.42	A2	78.50...78.51
	78.4...78.43	B2	78.51...78.52
	78.43...78.44	C2	78.52...78.53
6601237-P3	78.91...78.92	A2	79.00...79.01
	78.92...78.93	B2	79.01...79.02
	78.93...78.94	C2	79.02...79.03

Any damaged push rod tubes or cylinder head fastening studs should be replaced.

If leaks from the oil drain tube or push rod tubes are evident, clean the parts with degreaser and reseal with high temperature wicking sealant (gasket shellac or loctite).

Removing and Reinstalling the Piston and Piston Rings

(cylinder removed)

Required tools:

- piston pin remover tool 345-439-3
- piston ring remover tool 346-066-3
- mandrel tool 346-035 and tapered tip for mounting the wrist pin

To remove the piston and piston rings:

- mark the position of the piston
- remove the piston pin circlips
- fit the piston pin remover tool 345-439-3 and press out the pin (Fig. 4.4-1)
- remove the tool and take out the piston
- remove the piston rings with the help of remover tool 346-066-3 (Fig. 4.4-2)

NOTE: The normal service life of the piston rings usually exceeds 30,000 km of operation, provided that the motorcycle is maintained properly. Incorrect replacement of piston rings brings about wear of the rings and cylinder walls and will increase formation of carbon in the piston grooves, resulting in an increase of oil consumption due to burning of oil. The combustion chamber walls get fouled with carbon, the engine loses power while the consumption of fuel rises.

If reported oil consumption is greater than 1 pint per 500 miles / 250 g per 100 km and compression increases with added oil, it indicates a problem with piston-ring-bore fit. Check:

- wear of the cylinder
- play of the piston rings in the piston grooves
- deposits of carbon and sticky residue in the piston grooves
- the slots of oil rings
- oil holes in the piston grooves

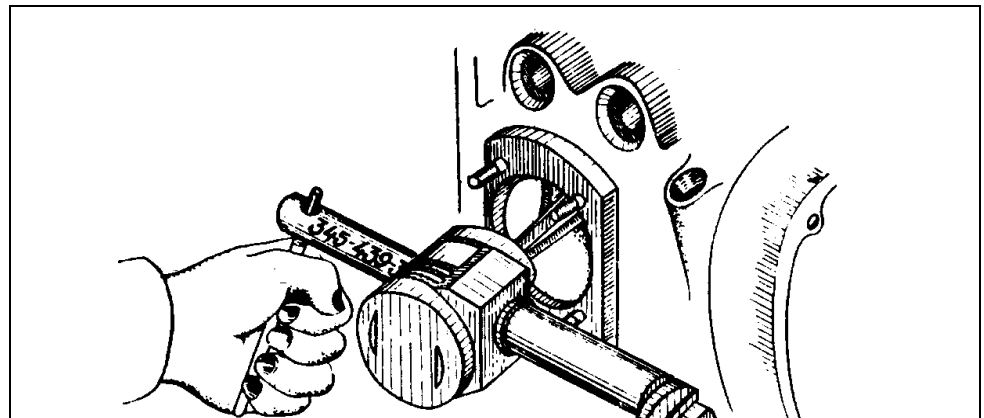

Fig. 4.4-1. Pressing-out the Piston Pin

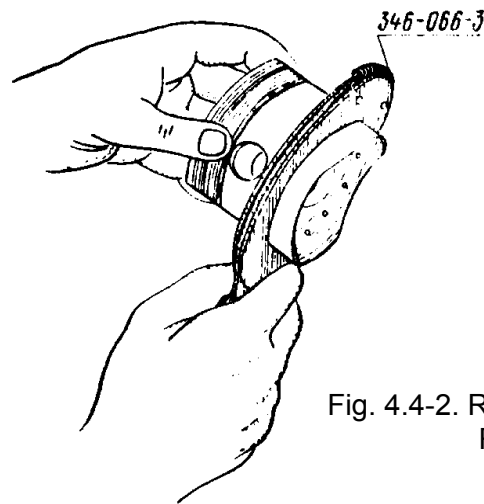
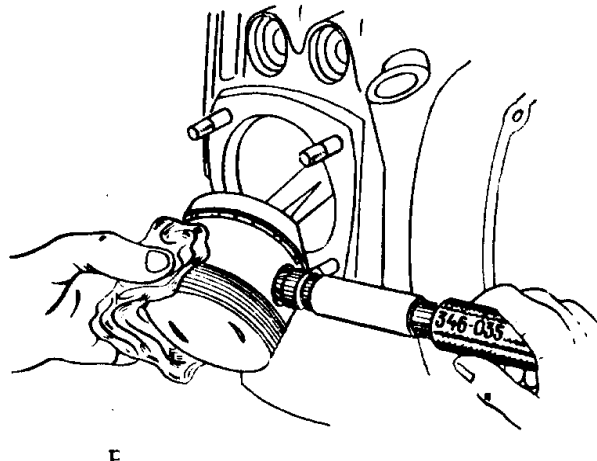

Fig. 4.4-2. Removal of Piston Rings

Fig. 4.4-3. Fitting the Piston



Before checking pistons and rings for wear, decarbonize thoroughly and wash the piston rings.

Inspect and measure the piston rings:

- for side clearance between ring and piston groove
- at several points around the ring for thickness ("height")
- in the most worn-out points on the ring circumference for ring width ("radial width")

Replace the piston ring if:

1. Large sections of surfaces not properly sealing to cylinder, cracks or chrome peeling, lack of resilience.
2. Side clearance between ring and piston groove (measured with feeler gauge) exceeds 0.003 inch / 0.082 mm.
3. The end gap (with ring fitted halfway into the cylinder) exceeds 0.045 inch / 1.2 mm.
4. Average ring thickness is less than the minimum size given in Table 4.4-1.
5. The width at worn spots around the contact edge is in excess of 0.106 inch / 2.7 mm.

Prior to fitting new rings on the piston, check clearances between the ring and piston groove with a feeler gauge.

For new compression piston rings the clearances should be:

- compression rings: 0.0015 to 0.0030 inch / 0.04 to 0.08 mm
- oil rings 0.001 to 0.003 inch / 0.025 to 0.065 mm

If the actual clearance exceeds the top limit given above by 0.001 inch (0.03 mm), try the fit of a different new piston ring. If, with a new ring fitted on, the clearance is still in excess of the upper limit, replace both the piston and rings.

NOTE: Whenever a cylinder is removed from a motorcycle with more than 20,000 km operation, it is advisable to change the piston rings, even if only slight wear of the bore is obvious.

The choice of ring size is dependent on the end gap with the new ring fitted into the cylinder. The normal end gap should be 0.010 to 0.020 inch / 0.25 to 0.50 mm, not to exceed 0.027 inch / 0.70 mm. If necessary, use an oversize ring with end gap filed to within limits.

Before inspecting and measuring the piston, remove carbon (especially its head and grooves), then wash it. Check for scoring, cracks on the piston skirt, and wear or damage of circlip grooves in the piston pin hole.

The tolerated wear of the piston pin hole should not exceed .0008 inch / 0.02 mm.

When fitting a new piston, select the size to match the actual size of the cylinder (refer to Table 4.4-1). If the cylinders are rebored, select pistons of the correct size to ensure a

clearance of .003 to .004 inch / 0.08 to 0.10 mm measured between piston skirt and cylinder bore. Whenever changing pistons, both pistons should be compared for balance.

Piston Pin

Inspect the outside surface of the piston pin to reveal scratches, dents, metal (bronze) flashes, and taper. Measure the pin on the edges and in the center, the wear should not exceed 0.0005 inch / 0.015 mm under minimum size of the color marking group (refer to Table 4.4-2).

NOTE: Piston pin condition and fitting is extremely important in URAL® engines. Pistons are carefully measured and sized according to incremental ranges identified by color markings placed on the bottom surface of the piston boss, and on the rod small end. To ensure the correct clearance within one color group, it may be necessary to try different pins with the same color marking. A lubricated piston pin should require firm finger pressure to pass through the rod bushing.

CAUTION: When changing the crankshaft, the connecting rod small end bush, the piston or its pin, it is necessary to select a new piston pin of the correct size as indicated by the color marking (on the inside surface of the pin, at one end) to match the marking on the holes of the piston bosses and the connecting rod small end bushing. Intermixing of piston pins and connecting rods from adjacent size groups is not recommended.

Reassemble the piston and piston rings in the following sequence:

1. Have mandrel tool 346-035 available.
2. Lubricate the piston pin with oil.
3. Heat the piston to 390°F / 200°C either by heating on an electric hot plate or by submerging it in hot oil.
4. Fit the pin on the mandrel, and from the other side insert the guiding tapered tip into the piston pin hole.
5. Match the hole in the piston and the hole in the connecting rod small end and press the piston pin in place by hand pressure on the mandrel (Fig. 4.4-3).

Table 4.4-2 Color Marking of the Piston Pin, the Connecting Rod Small End and the Holes in the Piston Bosses

Color index	Piston pin diameter, mm	Diameter of holes in connecting rod small end, mm	Diameter of holes in piston bosses, mm
White	21.000...20.9975	21.0095...21.0070	20.9930...20.9905
Black	20.9975...20.9950	21.0070...21.0045	20.9905...20.9880
Red	20.9950...20.9925	21.0045...21.0020	20.9880...20.9855
Green	20.9925...22.99000	21.0020...20.9995	20.9855...20.9830

Warning: Take care to protect yourself from burns while handling the hot piston.

Caution: The hot piston cools off quickly, and can seize the pin before it is fully centered between the circlip grooves. Never attempt to drive the pin into position with force. Only very light taps against the mandrel are permissible in order to adjust the position of the pin between circlip grooves. If the pin seizes, remove it with the piston pin remover, reheat the piston, and try again.

Having fitted the piston pin, insert the circlips, then fit the piston rings in place, using tool 346-066-3.

Cylinder Installation

NOTE: Prior to reinstalling the cylinder, turn the piston rings on the piston so that the ring gaps are not aligned and lubricate the cylinder face with motor oil.

When mounting the left-hand cylinder, see that the holes in the gasket are in line with the oil holes in the crankcase.

When mounting the cylinder on the piston, use clamping ring tool 345-037 to compress the piston rings in place (Fig. 4.4-4).

NOTE: Make sure that the sealing caps of the push rod tubes are correctly positioned (the arrow marked on the sealing cap should be pointing up) and tightly fitted in place. Be absolutely certain that the cylinder gasket does not overlap the oil hole.

The tightening torque of cylinder nuts is 30 - 40 ft/lbs. (36 Nm).

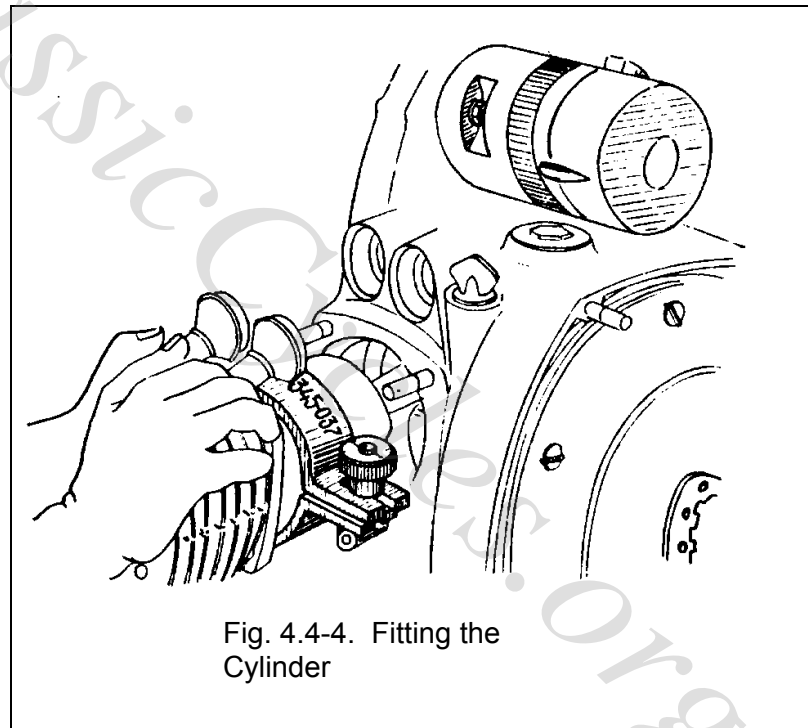

4.5 Camshaft, Timing Gears, Tappets

Camshaft servicing requires removal of engine from frame. Tappets may be removed with the engine installed.

Removing and Reinstalling the Camshaft

(With the timing covers, generator, both cylinders and all tappets removed.)

Required tools are:

- backlash indicator 450-182 for measuring the backlash between the teeth of timing drive gearing
- end play indicator 450-212 for measuring the end play of timing drive gearing
- mandrel 345-327-3 for removing the camshaft
- mandrel 345-341-3 for pressing in the camshaft

NOTE: Before removing the camshaft, measure the backlash between the teeth of timing gears and the runout of timing drive gearing.

To measure timing gear backlash:

1. Set up the backlash indicator 450-182 and fasten it on the upper right-hand threaded hole. Measure the clearance between the gearing teeth, then remove the tool (Fig. 4.5-2).
2. Set up the end play indicator 450-212 and fasten it on the right-hand threaded hole. Measure the end play, then remove the tool (Fig. 4.5-3).

Timing gear backlash in a new engine should be within .001 to .004 inch / 0.01 to 0.12 mm. Clearance variation in a pair of gears should not exceed .002 inch / 0.05 mm. Maximum clearance in service should not

exceed .011 inch / 0.30 mm measured at every tooth. End play or runout is tolerated within .016 inch / 0.04 mm.

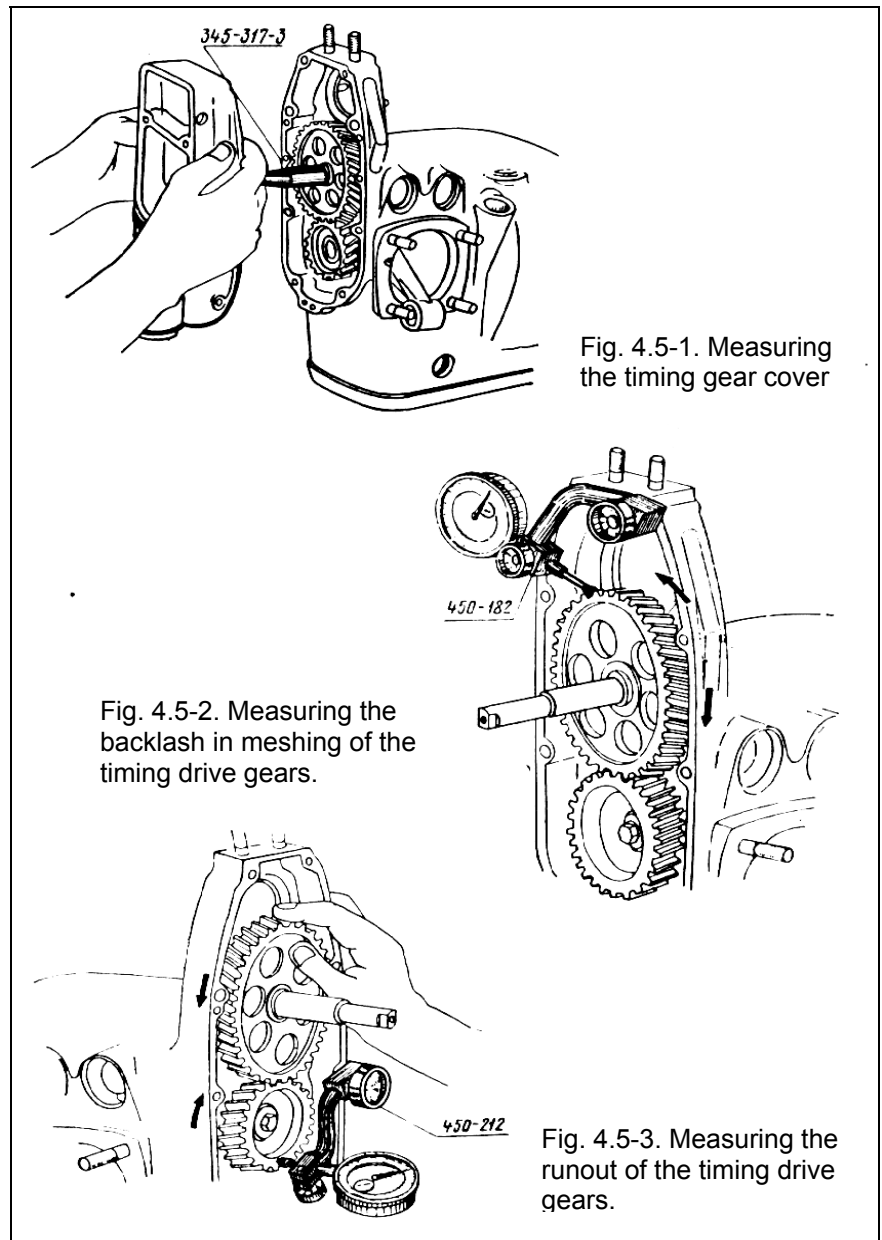

When inspecting the gears, whether used or new, pay special attention to the condition of their teeth faces, as even slight burrs and dents on a tooth will lead to noisy operation. Burrs and dents should be smoothed with a fine stone.

If timing gears are out of tolerance, preference should be given to replacement of both gears as a set, as a gear set is selected at the Manufacturing Works (by the sound of their running). Replacement of a single gear is possible, provided the measured backlash is then within limits.

Gear sets are selected according to crankcase "group" markings. The crankcase group of each engine is stamped on the upper surface of the crankcase to the right of the generator. Gear sets are marked on the gear faces.

Removing the camshaft:

1. Turn off the screws fastening the camshaft flange gaining access through the holes in the timing driven gear.
2. Remove the camshaft by pressing it out with mandrel 345-327-3, inserting it into the hole of removed guide of the left cylinder intake valve. turn the camshaft so the tool can push on the intake lobe, then rotate the tool to push the camshaft out.

Having removed the shaft, wash the parts, inspect, and make necessary measurements. The required tools are micrometers capable of measuring 0 to 1 inch / 0 to 25 mm and 1 to 2 inch/ 25 to 50 mm. Check the condition of the ball bearing at the camshaft front end; lubricate the bearing with engine oil, and carefully turn it by hand. If there is any perceptible notching of the races, change the bearing. Replace the camshaft, if the cam wear surfaces or bearings are scored, pitted or worn beyond limits.

Maximum permissible wear of the rear bearing is 0.04 mm/0.2 in.

To reinstall the shaft, reverse the sequence of the operations. Prior to pressing-in, lubricate the camshaft rear journal and the bearing with oil. Use mandrel 345-341-3 to press in the camshaft with light blows, the mandrel being fitted on the shaft end and thrusting against the gear hub.

As the gears mesh, ensure that the timing marks coincide.

Removing and Reinstalling the Tappets with Guides

(The engine may be left on the motorcycle, with the cylinder removed.)

The required tool is puller 345-331-3 for removing tappets.

To remove the tappets:

- undo the stop screws
- remove the tappets with guide making use of puller 345-331-3

NOTE: Mark the tappets and the guides when removing them, so that each tappet and guide can be reinstalled in the same position.

Having dismantled the parts, wash them, inspect, and make the required measurements. If necessary, change worn out parts. Check the camshaft contact faces of the tappets for wear or pitting, and check for cracks in the points where the tips are pressed-in. Observe the inner spherical surface which contacts the sphere of the push rod. Replace damaged or worn tappets.

The clearance between the tappet and guide should be within 0.10 mm / .004 in. In case of excessive clearance, change the tappet or guide to restore correct clearance.

Reinstall the tappets in the same positions. Lubricate the tappets with motor oil on installation.

4.6 Oil Pump and Delivery

Removing and Reinstalling the Oil Filter

To remove the oil filter from the distributor box cover, unscrew the filter plug and take off the filter together with the by-pass valve. Remove the filter from the plug end.

Wash the parts, inspect them and change the oil filter, as required.

CAUTION: The bypass valve is accurately adjusted at the factory. If the setting is disturbed, it must be readjusted to a main pressure of 10-13 psi / 0.07-0.09 MPa.

Reassemble the filter in the reverse sequence of the operations, taking care to insert the rubber packing ring. Replace the packing ring if it is questionable.

NOTE: Before installing the filter, soak it with clean motor oil.

Removing and Reinstalling the Distributor Box Cover (with the engine removed)

The required tool is tapered tip 345-317-3 for mounting the sleeve on the camshaft.

To remove the distributor box:

1. Drain oil from the engine crankcase.
2. Unscrew the fastener and remove the front cover.
3. Disconnect all the wiring from the ignition coil terminals and remove the ignition coil (remove two screws).
4. Remove the distributor cover; undo the screw fastening the automatic advance timer and remove the timer together with the distributor cam.
5. Take out the high-voltage wires together with the rubber bushings.
6. Turn off the screws fastening the cover and remove the latter by knocking it off with light blows.
7. Remove the breather.
8. Remove the gasket if damaged.

Having removed the distributor box cover, wash the parts (except for the ignition coil and wiring), inspect, and make necessary measurements. If necessary, replace the worn-out parts (refer both to Repairing the Engine Crankcase and Covers and to Ignition System).

Reinstall the covers reversing the sequence of operations; make sure that their breather slot enters the driving pin which is press-fitted into the timing driven gear. Lubricate the breather with oil, prior to reinstalling.

NOTE: If the gasket has been removed, clean the surfaces of the joint and apply a new coat of gasket cement to the surface at the joint on engine crankcase and install a new gasket, matching all the holes.

CAUTION: Make use of tapered tip 345-317-3 (Fig. 4.5-1); when mounting the timing cover, so as to preclude any damage to the seal lip.

Oil pump servicing

When overhauling the engine or when oil pressure is abnormally low, check and repair the oil pump.

To remove the oil pump:

1. Drain oil from the engine crankcase.
2. Undo the plug of the oil pump drive and remove the drive gearing.
3. Undo the screws fastening the engine sump; remove the sump together with the gasket.
4. Uncotter and take off the pump filter.
5. Turn off two bolts fastening the pump and remove the oil pump together with the bar as an assembly.

After removal, wash the oil pump thoroughly by submerging the pump casing in clean kerosene and rotating the oil pump driving gear shank. In a properly washed pump the gearing should rotate easily without seizing. If there is any evidence of seizing, disassemble the pump, inspect the parts carefully, and replace any substandard parts.

If facilities are available, check pump performance using a light oil (spindle oil grade B3). At a speed of 670 RPM the oil pump should develop a pressure of at least 56 psi / 0.4 Pa, or 4 kgf/cm², at a volume of .35 to .44 gallons per minute / 80 to 100 l/h.

To reinstall the oil pump, reverse the sequence of the operations. The crankshaft and camshaft must already be installed. When remounting the oil pump, ensure that the sealing gasket does not overlap the oil duct, that the pump casing fits tightly against the thrust surface, and that the drive shaft rod enters the square hole of the drive gear. With the oil pump installed, the engine sump (pan) can be installed and the oil pump screw plug installed.

The tightening torques are:

- oil pump bolt: 13 foot/pounds / 17.6 Nm
- engine sump: 7 foot/pounds / 9.8 Nm

Oil lines

In the course of total or partial dismantling of the engine, especially when reassembling, pay attention to correct mating of the oil ducts and clean them properly. Also see that the gaskets do not overlap the holes, the joints are tight with no leaks of oil.

In the event of total dismantling of the engine, check to reveal porous spots and pitting in the oil line of the engine crankcase.

Oil line checking procedure:

1. Close all oil holes in the engine block with rubber plugs, including the holes through which oil is fed to the left-hand cylinder, to the housings of front and rear bearings, and to the hole in the duct on the pump fastening plane. Attach a hose to feed water under pressure to the system.
2. Inspect all the oil lines, checking them for leaks of water.
3. If leakage is revealed, drain and dry the block, clean the area and seal with a high temperature oil-resistant sealant.

NOTE: When the plugs are removed, water should flow freely out of the holes, thus pointing to the cleanliness of ducts.

4.7 Removing and Reinstalling the Flywheel

(With transmission and clutch removed.)

Required tools and fixtures are:

- wrench 348-801 for turning off the flywheel fastening bolt
- remover 345-042-3 for removing the flywheel
- wrench 19x22 for locking the flywheel in place

To remove the flywheel:

1. Unbend the lock washer of the flywheel bolt.
2. Fit the wrench 19x22 between the hole for spring in the flywheel and the boss for stud fastening the engine crankcase.
3. Using wrench 348-801 turn off the flywheel fastening bolt and remove the lock washer.
4. Remove wrench 19x22.
5. Fasten the remover 345-042-3 on the flywheel; by turning in the central screw of the remover, remove the flywheel from the crankshaft tapered end (Fig. 4.7-1).
6. Take off the remover.
7. Having dismantled the flywheel, wash and inspect the parts; if necessary, replace worn out parts.

To reinstall the flywheel:

1. Fit the flywheel on the tapered end of the crankshaft; make sure that the rubber seal is correctly fitted on the flywheel hub and that the key coincides with the keyway in the flywheel hub.
2. Fit a lock washer on.
3. Install wrench 19X22.
4. Tighten flywheel fastening bolt, using wrench 348-80.

CAUTION: Since the flywheel bolt is critical, use a new bolt when reinstalling the flywheel, if possible. Tightening torque is 180 foot/pounds / 216 to 245 Nm.

5. Bend over the head of the lock washer to cover one of the bolt faces;
Remove wrench 19X22.

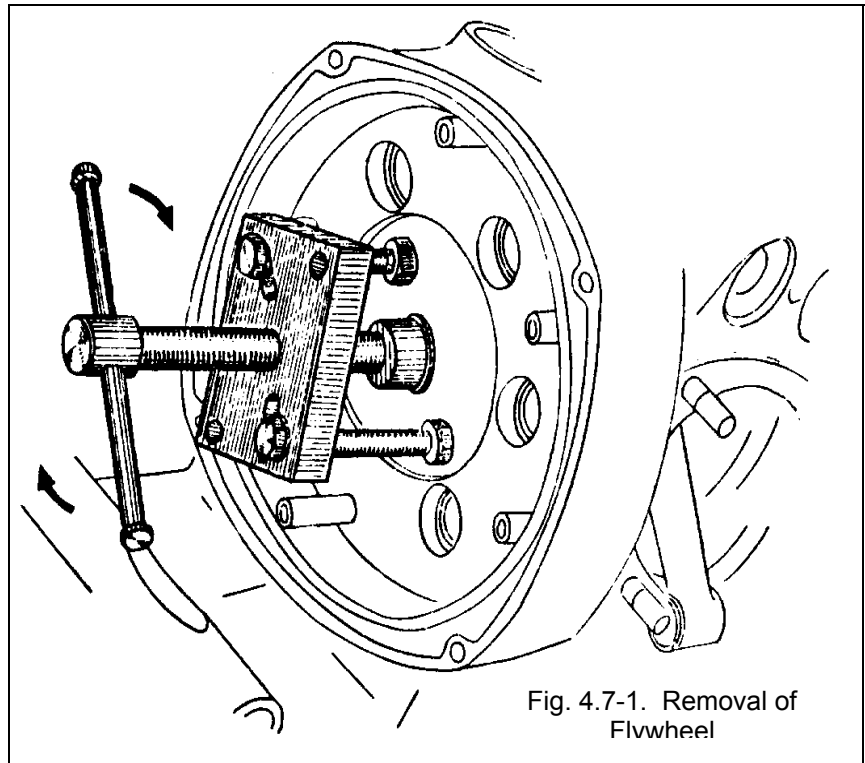

Fig. 4.7-1. Removal of Flywheel

4.8 Crankshaft and Connecting Rods

The connecting rods are an integral assembly of the pressed-together crankshaft. The crank assembly can be repaired if necessary, but if there are any significant problems, such as a loose rod lower end, it will probably be more economical to replace the assembly than repair it. If the crank assembly is repaired, the piston pins may also have to be replaced with pins of the correct color size grouping.

NOTE: A crankshaft that is merely out of alignment can be straightened, but a crank with damaged bearings or bent connecting rods can be expensive to repair. Before expending labor to repair a crankshaft, consider the price of a new crankshaft/connecting rod assembly ("crank mechanism, part #6601026, assembly"), which comes complete with connecting rods and piston pins.

CAUTION: Do not attempt to remove the crankshaft unless there is some indication the crankshaft or connecting rods need further inspection, measuring or repair.

The following troubles in the engine indicate crankshaft problems:

1. Abnormal rattling, squeaking or knocking in the main bearings or connecting rod big ends.
2. Bent connecting rods or excessively worn small end bushings.
3. Obvious play in rod lower ends.

Removing and Reinstalling the Crankshaft

(Engine out of frame; transmission, clutch, flywheel, camshaft, cylinders, pistons, and oil pump removed.)

Required tools are:

- Puller 345-339-3 for removing the timing drive gear and pulling the bearing from the crankshaft rear journal
- Tool 345-042-3 for removing the bearing rear housing
- Mandrel 345-334-3 for pressing-off the front bearing
- Ring 345-335-3 used with the mandrel for pressing-off the front bearing
- Tool 345-031 for pulling the crankshaft into the front bearing
- Tool 139-135 for pressing the bearing into the front housing

To remove the crankshaft:

1. Unbend the lock washer of the bolt fastening the timing drive gear, turn off the bolt, remove the drive gear with the help of puller 345-339-3 and remove the drive gear key.
2. Turn off the bolts and remove the rear housing making use of removing tool 345-042-
3. Turn off the bolts and take off the front housing cap.
4. Press the crankshaft front end out of the crankcase with the help of a press (while supporting the rear end of the crankshaft).

5. Turn the crankshaft to position the keyway of the flywheel facing up. Lifting up the front of the crankshaft will allow the rear portion to exit the hole in the crankcase (Figures 4.8-1 and 4.8-2).
6. If it is necessary to remove the rear bearing from the neck of the crankshaft, use puller 345-339-3. If the bearing is removed together with the rear housing, the bearing can be pressed out with mandrel 345-334-3.
7. Press the front housing and its bearing out of the crankcase. The bearing can be removed from the front housing with the help of a hand press, using mandrel 345-334-3 and ring 345-335-2.

Having removed the crankshaft, carefully clean the crankcase and crankshaft, especially removing accumulated grit and sludge from the oil catchers. Inspect all parts visually, and make necessary measurements. Dimensions of parts and tolerated wear limits are listed in Table 4.8-1. Parts worn beyond the limits or out of tolerance should be either repaired or replaced.

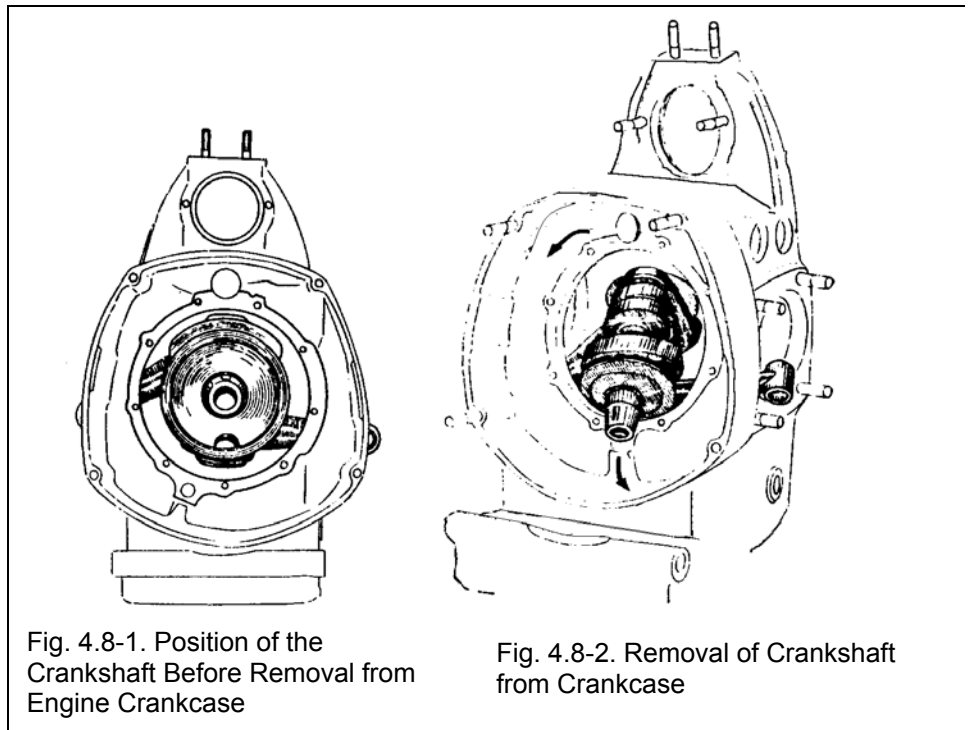

Crankshaft Inspection and Repair

Required tools and fixtures are:

- inside calipers with measuring range of 1.5 inch / 32 mm and 2.5 inch / 55 mm
- mandrel 345.333-3 for pressing off the connecting rod small end bush
- reamer 055-127-3, 21 mm dia., for reaming the hole in the connecting rod small end bush
- drill, .118 in / 3 mm dia.

Prior to inspection and measurements, clean the crankshaft oil catches of dirt and wash all the parts. By visual inspection check the general condition of the parts, especially the mated surfaces, in particular, those of the journals on which the main bearings are fitted.

To determine the condition and fitness of the crankshaft for further service measure the following:

1. Wear of the connecting rod small end bushes.
2. Radial play in the connecting rod big ends.
3. Axial play in the connecting rod big ends.
4. Runout of crankshaft main journals relative to each other.
5. Turning of the crankpins.
6. Alignment of the connecting rod small ends relative to the crankshaft axis.

Use the inside caliper with an indicator head for measuring the wear of the connecting rod small end bush. The wear should not exceed the values given in Table 4.8-1.

Table 4.8-1. Maximum Tolerated Limits of Wear and Clearances Between Principal Mating Members of the Engine. * MEASUREMENTS ARE IN MM *

Name of parts and mated pairs of parts	Maximum tolerance			Measuring point and method
	Wear on diameter	Out-of-round and taper	Diameter clearance	
Crankpin to rollers to connecting rod big end			0.100	
Crankpin	0.050			
Connecting rod big end	0.050			
Cylinder (face)	0.150	Out-of-round 0.070		In five points
Cylinder to piston			0.200	Measure piston in plane, square to pin axis to pin axis at point 5 mm from the piston lower edge
Piston pin	0.015			
Hole in piston to fit pin	0.020			
Piston to piston pin			0.010	
Connecting rod small end bush	0.025			
Piston pin to connecting rod small end bush			0.030	
Compression ring (height)	0.050			
Piston groove to piston ring			0.150 (by depth)	
Piston groove to oil control ring			0.150 (by depth)	
Valve stem	0.120			
Valve guiding bush	0.150			
Valve stem to guiding bush			0.250	
Rockshaft	0.070			
Rocking arm (aperture)	0.070			
Rockshaft to rocking arm			0.120	
Tappet	0.050			
Tappet guide	0.050			
Tappet to tappet guide			0.100	

If the rod bushing wear exceeds the tolerated limits:

1. Press off the worn-out bushing with the help of mandrel 345-333-3 using a hand press, and press in a new bush.
2. Drill two .118 inch / 3 mm dia. holes in the bushing for lubricating the piston pin through oil holes provided in the connecting rod small end, roll the bushing into the slots of the small end and ream the bushing with the help of reamer 055-127-3.
3. Measure the actual size of the hole, mark it as indicated in Table 4.8-1 and select a piston pin of respective color. An oiled pin should be a firm finger press fit into the rod bushing.

Measure the radial play in the connecting rod big end using a dial indicator by resting the feeler pin on the big end in the centers (Fig. 4.8-3).

The radial play must be within .004 inch / 0.10 mm. Measure the axial (side) play between the crankshaft cheeks and the connecting rod big end using a feeler gage. Axial play must be within .008 to .013 inch / 0.20 to 0.34 mm (Fig. 4.8-4).

Measure the runout of crankcase main journals relative to each other in centers using an indicator. The runout shall be within .002 inch /

0.05 mm. (Fig. 4.8-5) Should the actual runout exceed this value, the crankshaft must either be straightened or replaced.

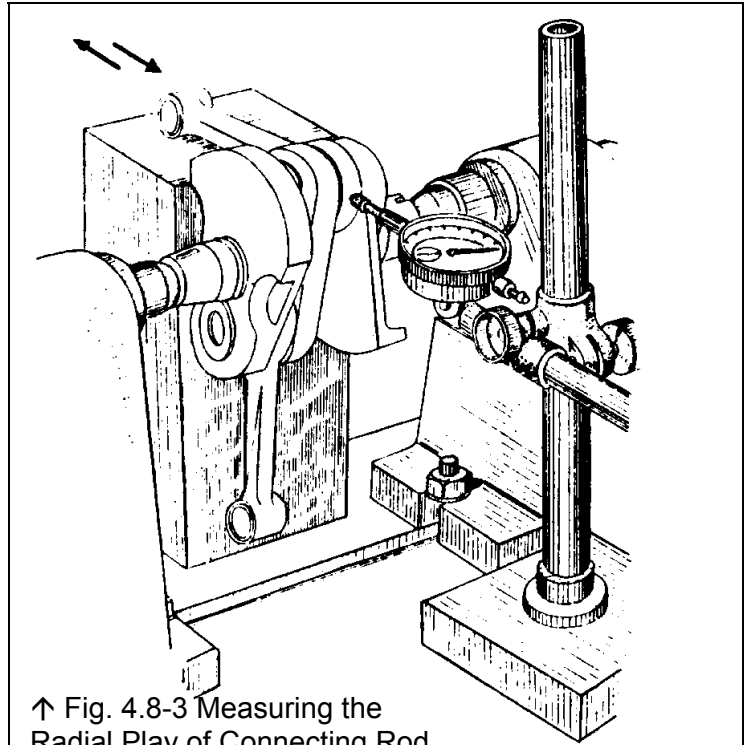

↑ Fig. 4.8-3 Measuring the Radial Play of Connecting Rod

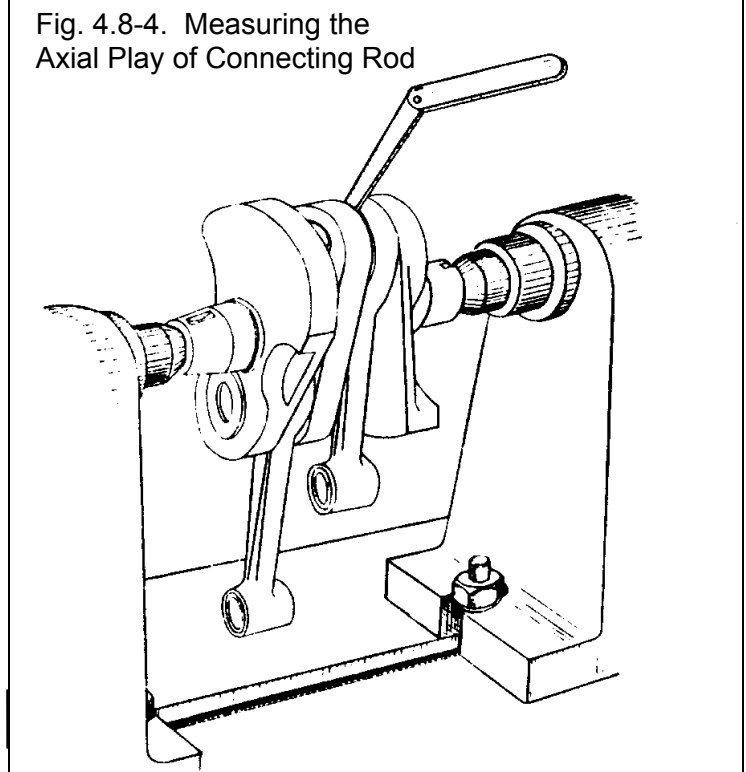

Fig. 4.8-4. Measuring the Axial Play of Connecting Rod

The pointers of both indicators should deviate in the same sense, i. e. positive or negative (Fig. 4.8-5, 2 and 3). If the indicator pointers read different values (Fig. 4.8-5, 1), then determine the peak point on the crankshaft main journal (1 - left-hand journal), and, by clamping the crankshaft cheek in the vice, knock slightly against the left-hand journal (arrow A, 1).

If the pointers of indicators read the same negative deviation which exceeds the tolerated value, then knock inwards as indicated by arrow (B-2). When the deviation is positive, spread out the journals (arrow C, 3) making use of lever (P, 3) for the purpose, or press 4.

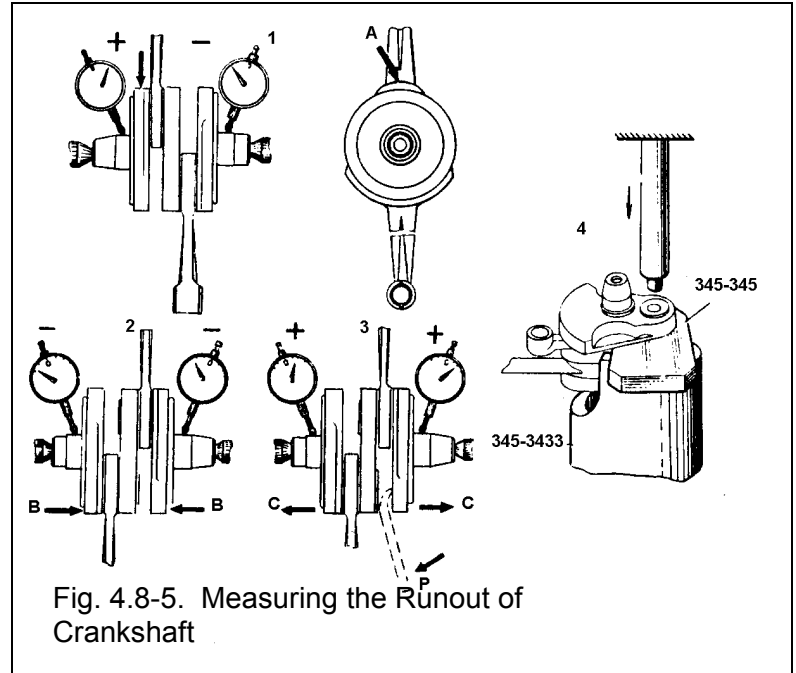

Fig. 4.8-5. Measuring the Runout of Crankshaft

Measure the turning of the crankpin in the centers using the indicator. Insert mandrel 457-034 into the connecting rod small ends; choose the mandrel color to match that of the small end holes. Measurements should be taken in two positions of the crankshaft (Fig. 4.8-6, a and b). The difference in measurements should not exceed 0.5 mm / 0.2 in. If otherwise, straighten out the crankshaft by carefully knocking with a copper hammer against the respective sides of the journals. Thereupon, check the runout of the main journals.

Check the connecting rod small ends for proper alignment with the crankshaft axis by sliding the mandrel through both rod ends. If the mandrel will not slide through both holes, that indicates a bent rod.

If, on disassembly, the crankshaft is beyond the service wear limits, it must be replaced (see Table 4.8-1).

CAUTION: Do not attempt to straighten a connecting rod, once the crankshaft is assembled.

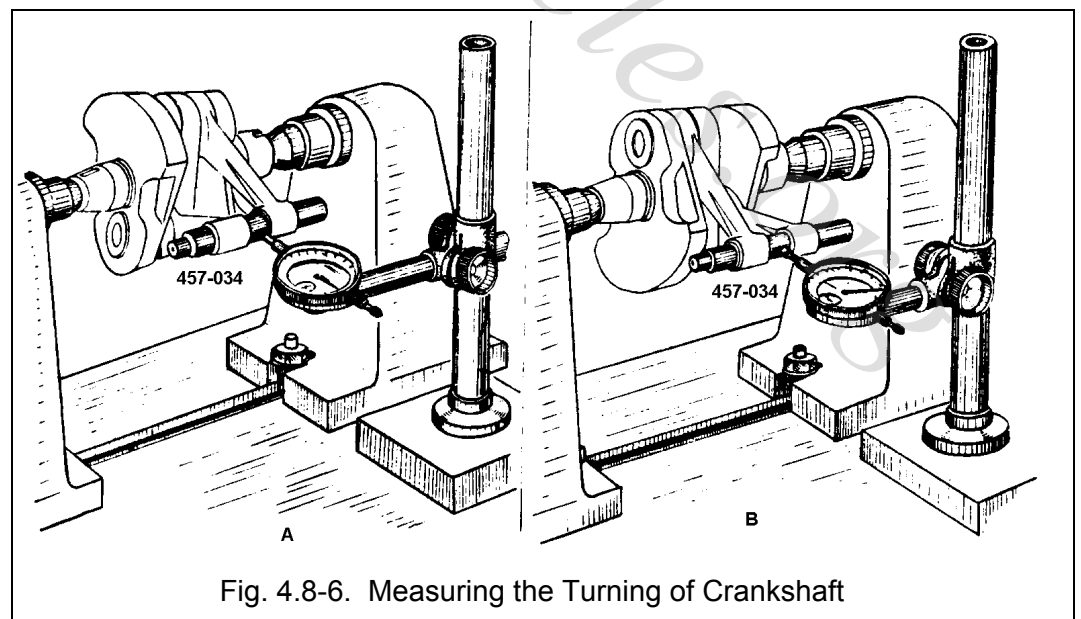

Fig. 4.8-6. Measuring the Turning of Crankshaft

Crankshaft Installation

Install the new or rebuilt crankshaft into the engine crankcase, observing the following sequence of operations:

1. Press the bearing into the front housing with the help of tool 48-139-135 and the housing into the crankshaft aligning it with bolts relative to the fastening holes.
2. Fit the front housing cap and turn home the bolts. Tightening torque of front housing cap bolts is 13 foot/pounds (17.6 Nm).
3. Position the crankshaft so that the keyway is located on top, enter the connecting rods into the crankcase, guiding them into the holes provided for the cylinders, and tilt the crankshaft into the engine crankcase. (see Fig. 14.8-2).
4. Use replacer tool 345-031 to mount the crankshaft front end into the front bearing (Fig. 4.8-8).
5. Press the oil seal and the bearing into the bearing rear housing;
6. Coat the crankcase rear sealing surface of the crankcase with gasket cement, fit a gasket on the rear bearing housing, and press it into the crankcase, taking care to align the bolt holes.
7. Prior to reassembly, clean the thread and surfaces from old paint, and degrease them.
8. Fasten the bearing housing with bolts, having coated the threads with enamel, painting half of the whole thread. (or use a removable-type liquid thread sealant). Tighten the bolts in a criss-cross sequence. Tightening torque of cap bolts is 13 foot/pounds / 17.6 Nm.
9. Fit the keys into the front and rear ends of the crankshaft.
10. Press the driving gear on the crankshaft, fit the timing drive gear washer, having matched the slot in the gear with the protruding end of the key. Fit the lock washer and secure it with a bolt, tightening to torque of 20 foot/pounds / 27 Nm.
11. Lock the bolt with the lock washer by bending it over onto the bolt face.

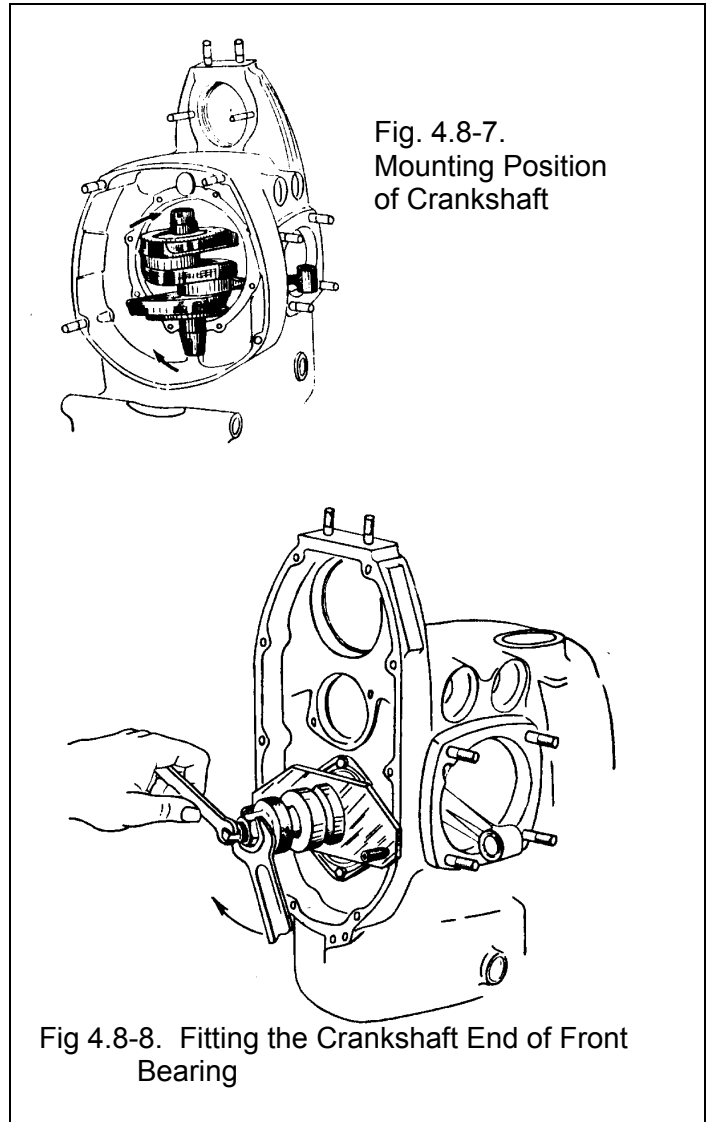

Fig. 4.8-7.
Mounting Position
of Crankshaft

Fig 4.8-8. Fitting the Crankshaft End of Front
Bearing

4.9 Crankcase and Covers

In the course of an overhaul or partial dismantling of the engine, check the condition of the crankcase and the engine covers. Pay attention to:

- cracks or other damages
- dents, burrs, etc. from the previous gaskets
- worn-out spots on contact surfaces, especially in bearing lands
- loose studs, stripped thread
- loose flaring or pressing-in of pipes
- wear of the camshaft rear bearing (bushing)
- scores on the oil pump drive bushing
- wear or scores in the holes for the breather on the gearbox cover

Defective parts must be replaced or repaired. There are metal based casting rebuild materials which can be used to repair surfaces such as bearing lands and gasket surfaces. If bearing surfaces of shafts or bushings are damaged, the parts should be replaced.

Gearbox

5.1 Description and Specifications

The URAL[®] gearbox has four ratios forward, and one ratio reverse (sidecar motorcycles only). A foot shift lever is on the left side, and the reverse lever on the right side. A kick starter pedal on the left rear of the gearbox drives the gearbox to start the engine. The gearbox is bolted to the rear of the engine crankcase, enclosing a dry clutch. Output of the gearbox is on the right side via a rubber collar to a solid driveshaft with universal joint. The gearbox shift linkage is externally adjustable. The gearbox can be removed from the motorcycle without removing the engine.

Figure 5.1-1. Development of Shafts (with reverse gear engaged)

- 1 - Gear of clutch shaft IV gear
- 2 - Clutch shaft bearing
- 3 - Clutch shaft seal
- 4 - Clutch shaft
- 5 - Clutch release rod
- 6 - Clutch shaft sleeve
- 7 - Packing ring
- 8 - Front gearing cover washer
- 9 - Main shaft bearing
- 10 - Engagement sleeve of III & IV gears
- 11 - Oil washer of main shaft
- 12 - Gear of main shaft IV gear
- 13 - Main shaft sleeve
- 14 - Gearbox case
- 15 - Gear of secondary shaft III gear
- 16 - Kick start shaft busing
- 17 - Gear of main shaft II gear
- 18 - Engagement sleeve of I & II gears
- 19 - Intermediate gear bracket
- 20 - Kick starter spring
- 21 - Kick starter gear cluster
- 22 - Kick starter shaft seal
- 23 - Kick lever
- 24 - Kick starter shaft
- 25 - Intermediate gear
- 26 - Gear of main shaft I gear

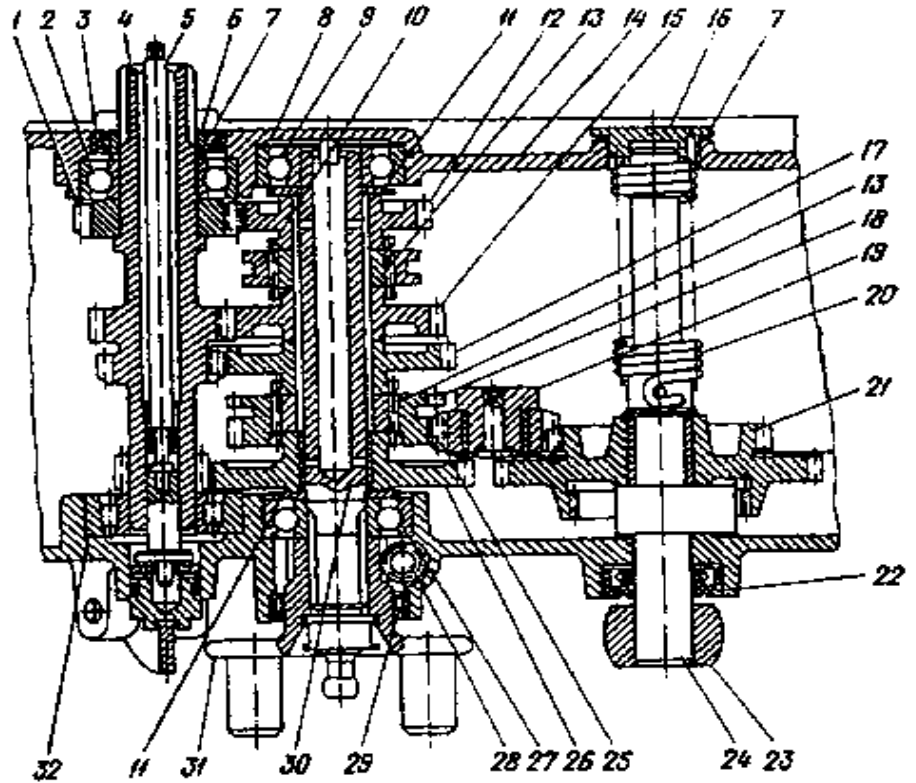

- 27 - Main shaft bearing
- 28 - Driven gear to speedometer
- 29 - Main shaft seal
- 30 - Main shaft
- 31 - Flexible disk of propeller shaft sleeve
- 32 - Clutch shaft roller bearing

The principal parts of the gearbox are the split box with covers, the clutch shaft and the main shaft with gears and shift sleeves, the gear shift mechanism, the kick starter and the reverse gear engagement mechanism (Figure 5.1-1).

The clutch shaft is supported on ball and roller bearings. The shaft is made integral with the gear rims of the 1st, 2nd and 3rd gears. The 4th gear is set on a segment key.

The main shaft is supported on two ball bearings. The pinions of the 1st, 2nd, 3rd and 4th gears rotate freely over the outer surface of the splines. Two sleeves are set on the splines of the main shaft, and gears are connected with the shaft by a sliding sleeve. Involute teeth are threaded on the outer surface of the engagement sleeve of the 1st and 2nd gears. Bronze bushings are pressed into the gear holes of the kick starter, intermediate and I gear of the main shaft. The gears are lubricated through labyrinth cavities in the casing, and bores in the shafts.

The kick starter (Fig. 5.1-1) consists of shaft (4) with pawl (7), the kick lever with the pedal, return spring (1) and kick starter gear (3). The shaft is supported by the bushings provided in the gearbox casing.

Gear changing is performed by a quadrant which moves shaft forks to engage the gears in sequence. Each stroke of the shift lever moves the shift quadrant to select either one lower or one higher ratio. The shift mechanism is shown in Fig. 16. The gear shifting is performed in a definite succession. The lower gears are engaged by depression of the pedal front arm, while the higher gears, by depression of the pedal rear arm.

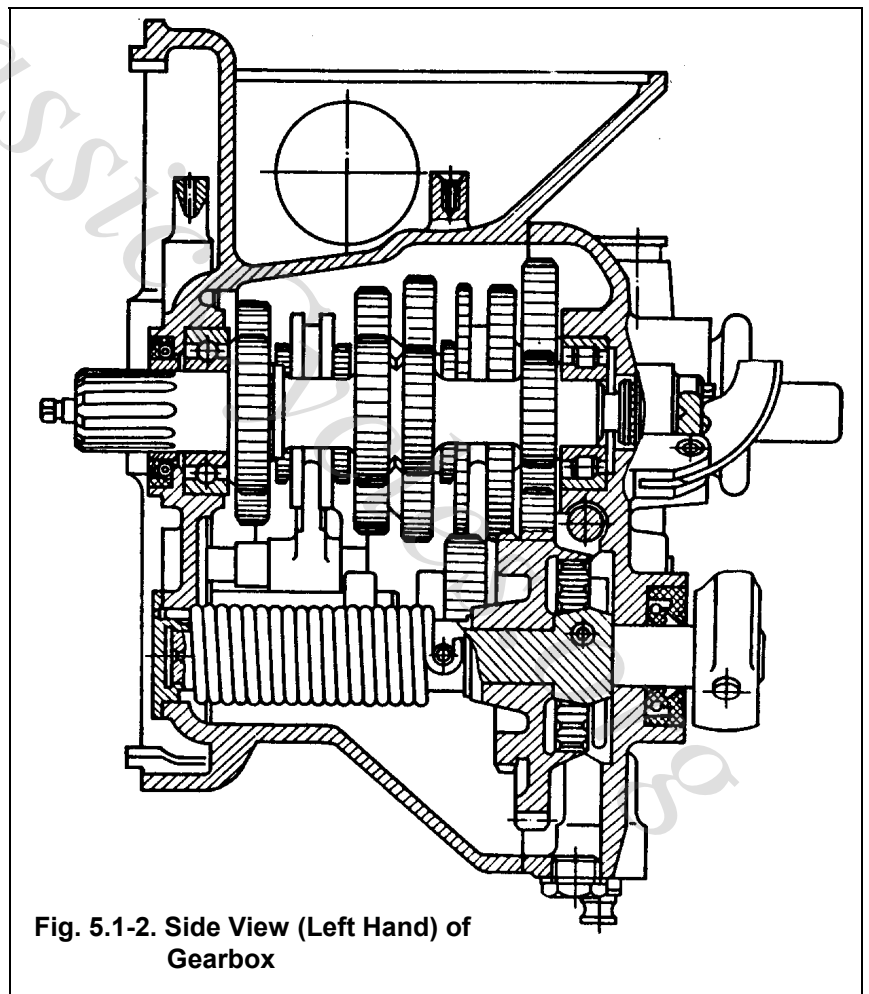

Fig. 5.1-3. Top View Of Gearbox

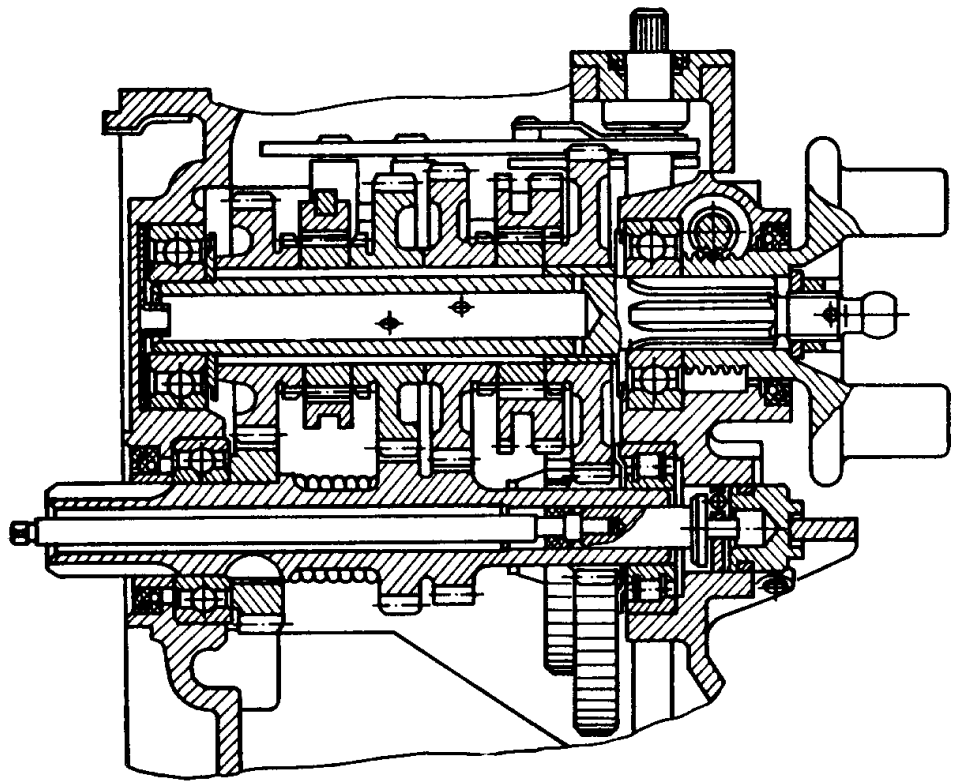

Figure 5.1-4. Kick Starter

- 1 - Return spring
- 2 - Kick starter shaft bushing
- 3 - Kick starter gear
- 4 - Kick starter shaft
- 5 - Pawl spring
- 6 - Spring pin
- 7 - Pawl
- 8 - Pawl axle
- 9 - Pawl release
- 10 - Kick starter buffer pin
- 11 - Buffer plug
- a - Pawl engaged
- b - Pawl disengaged

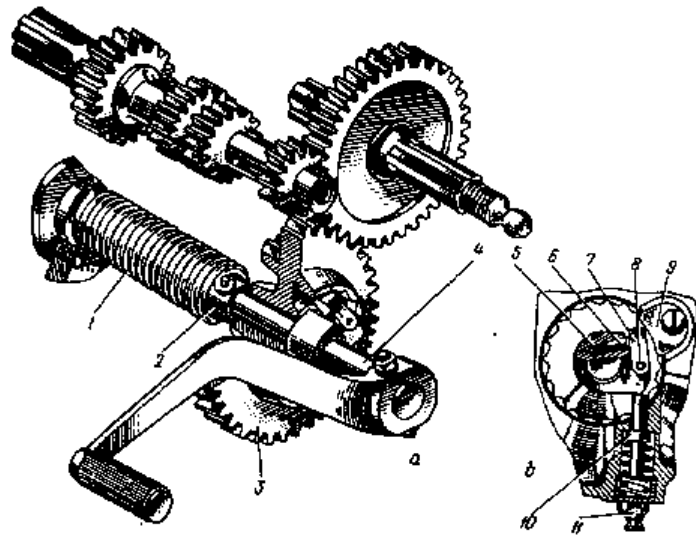

Figure 5.1-5. Gear Shift Mechanism

- 1 - Gear shift pedal
- 2 - Pawl with tenon
- 3 - Return spring
- 4 - Ratchet
- 5 - Pawl crank with pin
- 6 - Lock ring
- 7 - Quadrant shaft spring
- 8 - Gear shaft quadrant
- 9 - Hand gear change lever
- 10 - Quadrant lock
- 11 - Gear change fork shaft
- 12 - Shift fork of 3rd and 4th gears
- 13 - Shaft fork of 1st and 2nd gears
- 14 - Nut
- 15 - Pawl crank lever
- 16 - Sleeve
- 17 - Seal

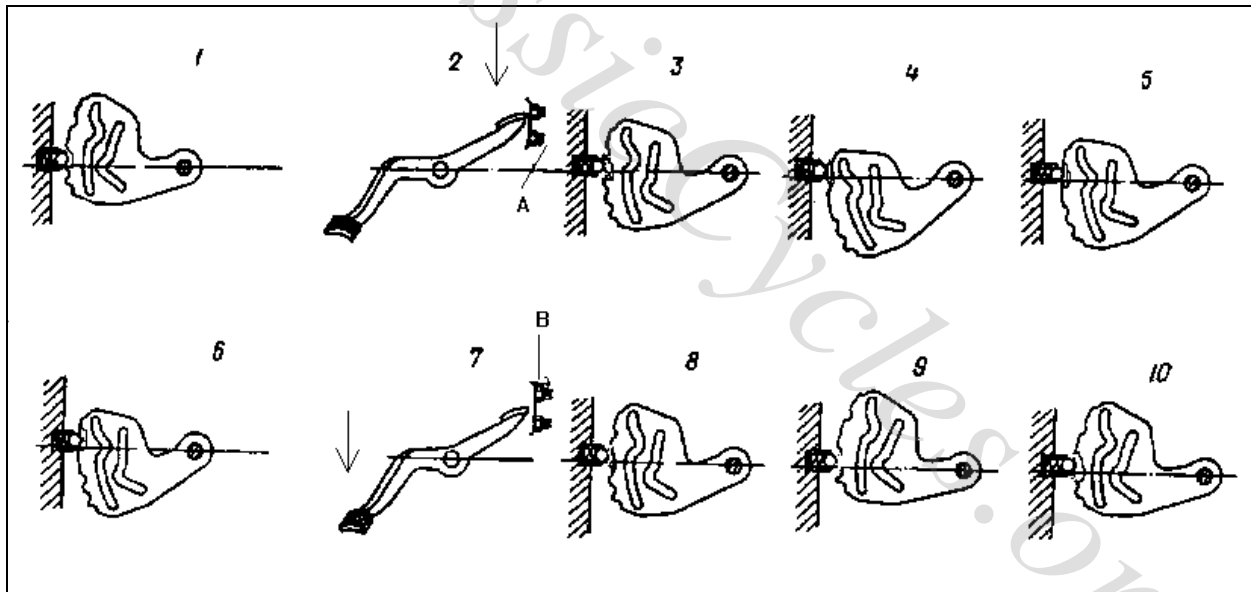
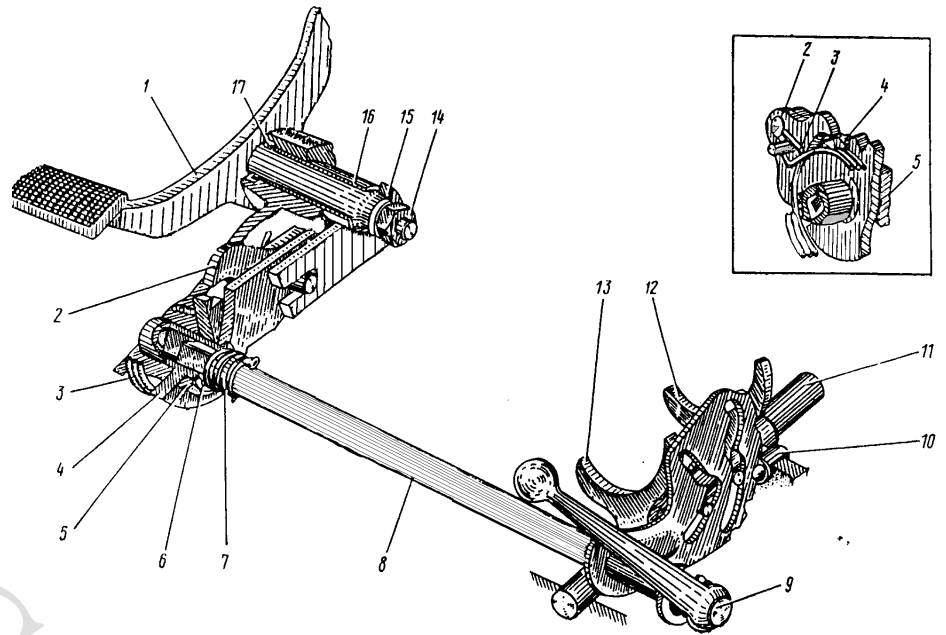

Fig. 5.1-6. Schematics of Gear Shift Adjustment Mechanism

The reverse gear engagement mechanism consists of a separate quadrant (10) with a shaft and reverse gear engagement lever (9). Reverse can only be engaged from either 1st gear or neutral. Shifting from reverse to forward automatically places the gearbox in neutral.

When the reverse gear is engaged, the intermediate gear travels with the bracket along the shaft and connects the small rim of the starting gear with the rim of the sleeve engaging the 1st and 2nd gears on the main shaft. When the right-hand lever is turned to one third of its travel the gear shift mechanism is set to neutral position. The bracket with an intermediate gear will not move, and the gear is set in neutral position. When the reverse gear engagement quadrant is turned further, the bracket with an intermediate gear travels along the shaft, the reverse gear is engaged, and simultaneously the gear shift quadrant is blocked, thus possibility of simultaneous engagement of two gears is excluded. When the reverse gear engagement lever is returned to its forward position, the gear shift quadrant is set into the neutral position.

5.2 Gearbox (Solo motorcycle)

The gearbox on Solo (two-wheeled) URAL®s is similar to the sidecar models except it has no reverse gear. A hand gear change lever on the right side is connected directly to the shift quadrant. The 1st gear is engaged when the gear change lever is pulled back as far as possible, while by pushing the lever forward, the 2nd, 3rd and 4th gears are engaged one after another. The neutral position (idling) is obtained by setting the lever between the 1st and 2nd gears. The hand lever assures not only shifting of the gears in succession, but also in any versions, for instance, from the lowest gear directly to the highest one and vice versa. The main application of the lever, however, is to set the gearbox sleeves into the neutral position.

The principal parts included in the gearbox (Fig. 5.2-1) are: the split box with covers, the clutch shaft and the main shaft with gears and shift sleeves, the gear shift mechanism and the kick starter.

The gear shift mechanism is illustrated in Fig. 5.1-5. The hand gear change lever on the right may be in five different positions. The foot shift pedal functions the same as the sidecar gearbox. The solo gearbox shift stops are adjusted in the same manner as the sidecar gearbox.

Troubleshooting

Problem:

1. Gearbox skips 3rd on upshift.
2. Gearbox skips 2nd on downshift.
3. Hard to shift up.
4. Hard to shift down.

Solution:

- Back out A screw 1/8 turn.
- Turn in B screw 1/8 turn.
- Back out A screw 1/8 turn.
- Back out B screw 1/8 turn.

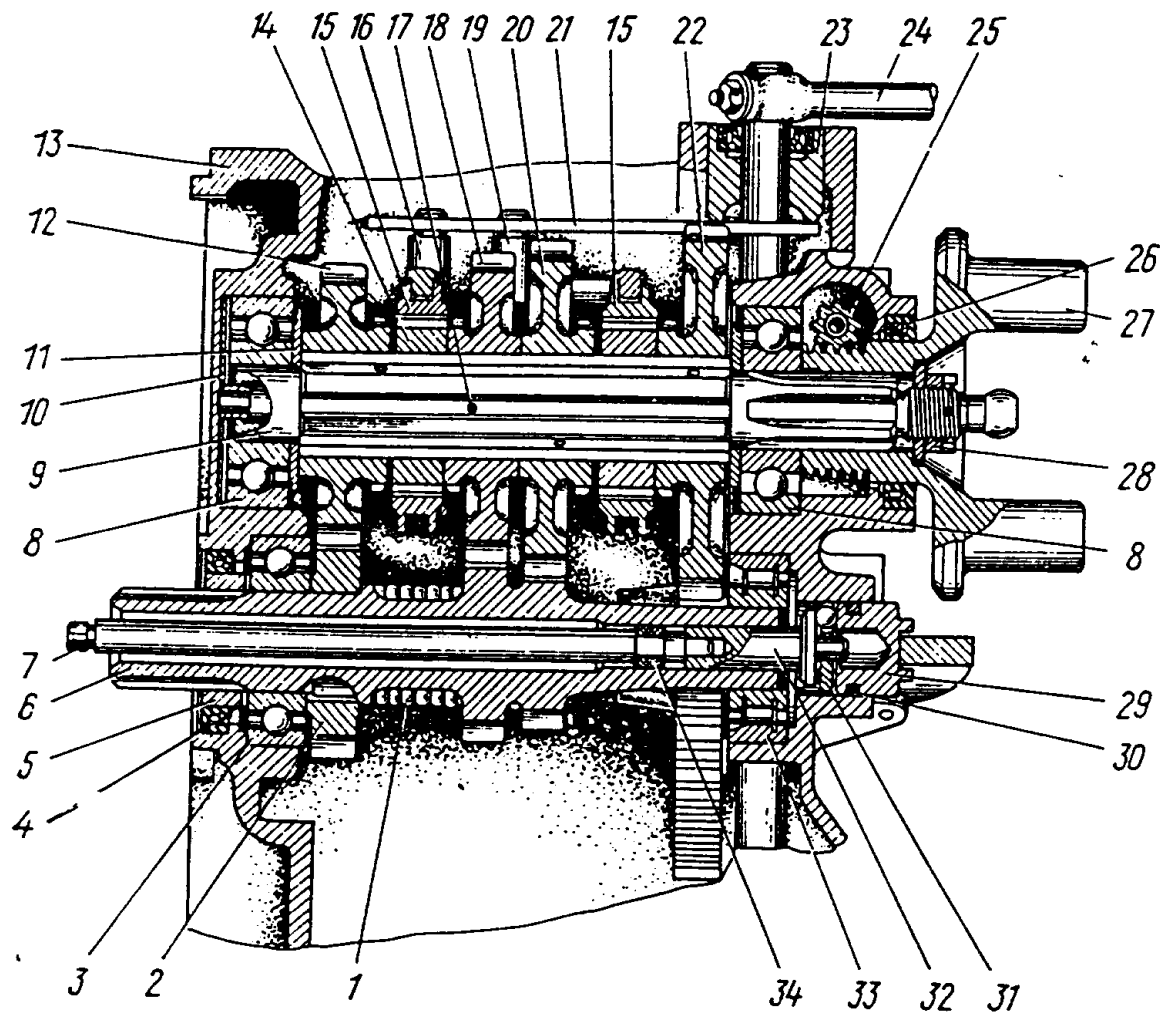
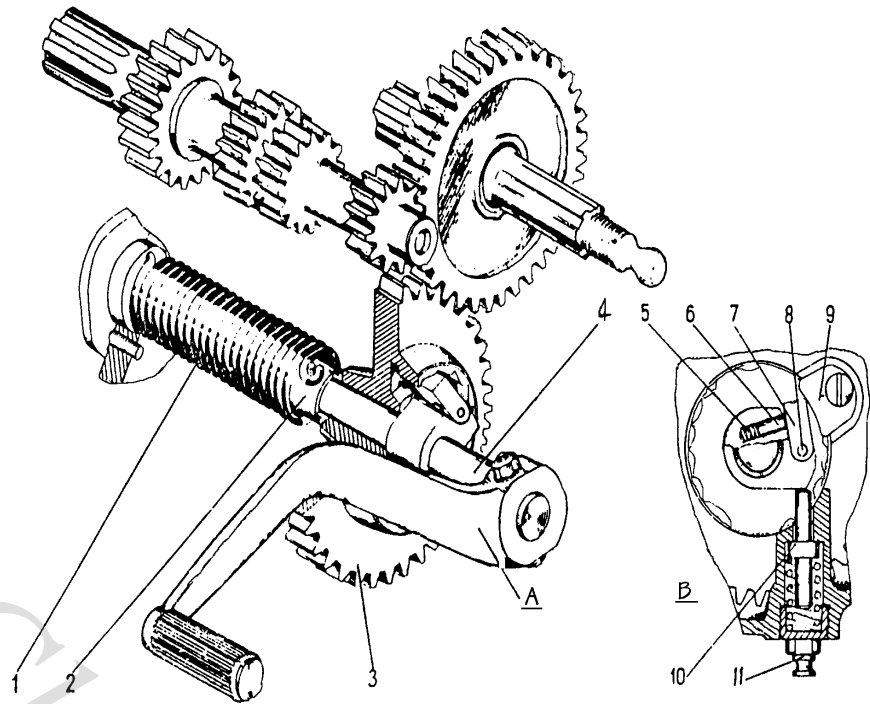

Figure 5.2-1. Solo Gearbox (section through shafts)

- | | | |
|-------------------------------|---------------------------------|--|
| 1 - Starter spring | 12 - Gear IV of main shaft | 23 - Right hand cover of gear case |
| 2 - Gear IV of clutch spring | 13 - Clutch crankcase | 24 - Hand gear change lever |
| 3 - Clutch shaft ball bearing | 14 - Main shaft sleeve | 25 - Speedometer driven gear |
| 4 - Clutch shaft seal | 15 - Gear shaft sleeve | 26 - Main shaft seal |
| 5 - Clutch shaft sleeve | 16 - Gear III and IV shift fork | 27 - Driving plate of flexible coupling of propeller shaft |
| 6 - Clutch shaft | 17 - Hole for oil feed to gears | 28 - Main shaft nut |
| 7 - Clutch release rod | 18 - Gear III of main shaft | 29 - Clutch release slider |
| 8 - Main shaft ball bearing | 19 - Gears I and II shaft fork | 30 - Slider seal |
| 9 - Main shaft | 20 - Gear II of main shaft | |
| 10 - Front bearing cap washer | 21 - Gear shift quadrant | |
| 11 - Oil washer of main shaft | 22 - Gear I of main shaft | |

Figure 5.2-2.
Kick Starter

- 1 - Return spring
- 2 - Kick starter shaft bushing
- 3 - Kick starter gear
- 4 - Kick starter shaft
- 5 - Pawl spring
- 6 - Spring pin
- 7 - Pawl
- 8 - Pawl axle
- 9 - Pawl release
- 10 - Kick starter buffer pin
- 11 - Buffer plug
- A - Pawl engaged
- B - Pawl disengaged



www.ClassicCycles.Org

5.3 Shift Mechanism Adjustment

Shifting problems can often be traced to incorrect shift mechanism adjustment. Before removing a gearbox for service, first adjust the mechanism.

To prepare the motorcycle for adjustment of the gear shift mechanism (shift quadrant), put it up on the center stand on top of a flat block of wood, so that the rear wheel can rotate freely. Put the motorcycle in neutral by shifting the right-hand lever(9) (see Fig. 4.9-5) back (into reverse) and then forward.

Shift Stroke Adjustment

Loosen the locknuts on both of the gear shift adjusting screws (Fig. 5.1-5 and 5.1-6) located at the left rear face of the gearbox. These screws restrict the turn of the pawl crank (Fig. 5.1-5), and consequently, the stroke of the gear shift pedal. A spring loaded ball drops into detents that hold the shift quadrant in position. The upper screw (B) regulates the stroke when shifting down. The lower screw (A) regulates the stroke when shifting up. Proceed as follows:

1. Back out both limit screws, adjusting about 1/8".
2. Position the locknuts on both adjusting screws so approximately 3 threads are exposed.
3. Screw the adjusting screws into the case until the locknuts touch the case.
4. Remove the black plastic cap located in the right side of the gearbox above the reverse gear lever.
5. Place a 10 mm wrench over the nut located on the right side of the gearbox above the reverse gear lever.
6. Position your body as follows:
 - use your left foot to press the gearshift pedal
 - hold the 10 mm wrench positioned as described in number 5 with your left hand
 - every time you make shifts between the gears by pressing the gearshift pedal, rock the rear wheel back and forth with your right hand to make sure it rotates freely and the gears are able to engage in the new ratio. When first learning this procedure, it may be easier to have an assistant rock the rear wheel.
7. Press down on the rear of the shift pedal (by doing this you shift to 3rd gear). Your hand holding the wrench lightly should feel the "click". Do not push on the wrench, just use it to feel when the spring loaded ball has seated in a notch in the shift quadrant. Keep pressing the pedal after you feel this "click" and if the wrench moves further after the "click", use your right arm to screw the lower adjusting screw slightly in. After

doing this, move the wrench back to 2nd gear position and repeat the above test. Keep testing and making adjustments by screwing the lower screw in until the

wrench stops moving further after the “click” is felt. At this point you have correctly adjusted the stroke of the shift pedal for shifting from a lower gear to a higher gear.

If you feel no click at all, this means that the shift pedal stroke is too small. You should screw out the lower adjusting screw, still pressing the rear of the pedal shift and continuing to rock the wheel until you feel a definite “click”.

Now your URAL® is in 3rd gear.

8. Press the front of the shift pedal while rocking the rear wheel back and forth to allow shifting from third to second gear. Your hand holding the wrench should feel the “click” as the spring loaded ball drops into the detent in the shift quadrant. Keep pressing the pedal after you feel this “click” and if the wrench moves further after the “click”, it has gone past the detent. Use your right arm to screw the upper adjusting screw slightly in. After doing this, move the wrench forward to 3rd gear position and repeat the above test. Keep testing and making adjustments by screwing the upper screw in until the wrench stops moving further after the “click” is felt. Remember to continue to rock the rear wheel while keeping pressure on the shift pedal.

If you felt no “click” at all, you should screw out the upper adjusting screw, still pressing the front of the pedal shift until you feel a definite “click”.

9. Now your URAL® gearbox is adjusted. You may want to repeat number 6 and 8 procedures again to double check that the wrench stops immediately after the “click” is felt. After adjustments, tighten the locknuts on both adjusting screws and put the plastic cap back over the nut as described in number 5.

Neutral Switch Adjustment

Following shift stroke adjustment, check the operation of the neutral switch. Adjusting the shift stroke tends to disturb the neutral switch adjustment. If the neutral light does not illuminate with the gearbox in neutral, the switch can be adjusted as follows (engine off).

1. Shift the gearbox to neutral.
2. Slacken the wire terminal fastening nut and pickup screw locking nut.
3. Switch on the ignition.
4. Turn the pickup screw in or out, until the green neutral light on the dashboard illuminates.
5. Check that the neutral light goes out as the gearbox is shifted to 1st and illuminates when it is shifted back to neutral. Do not screw in the adjusting screw any farther than needed. If it is screwed in too far, it can prevent the gearbox from shifting properly.
6. Lock the screw with the nut and secure the pickup wire terminal.

5.4 Gearbox Removal and Installation

Tools:

- Crank handle 345-316-3
- Tool 345-429-3

Gearbox removal without removing the engine from the motorcycle:

1. Remove the air cleaner and the battery.
2. Disconnect the adjusting bolt of the clutch control cable from the clutch engaging lever at the gearbox.
3. Undo the bolt of speedometer drive bushing, take out the speedometer drive and move aside, then reinstall the bolt.
4. Disconnect the wire from the contact (switch) of the neutral switch.
5. Remove the rear wheel, the final drive, the flexible coupling joint driven flange with the flexible coupling joint driving flange of the gearbox, the intake branch pipes leading to the carburetors.
6. Undo three nuts and a fastening bolt located under the right-hand cylinder which fasten the gearbox to the engine crankcase.
7. Shift the gearbox to the rear and remove it from the frame.

Reinstall the gearbox on the engine in the reverse order.

Important: before reinstalling the gearbox attend to the following:

1. Center the hub splines in the clutch driven disks making use of crank handle 345-316-3 or the splined end of tool 345-429-3 and, if necessary, adjust the hubs position so that the tool end slides easily into the splined holes of both hubs.
2. By turning the shaft, arrange the splines of the gearbox primary shaft to mate those of the clutch driven disks.

When reinstalling the gearbox:

1. Push the clutch disengaging rod somewhat forward.
2. Insert it into the square hole of the clutch pressure plate.
3. While pushing the gearbox forward into place, insert the primary shaft into the splined holes of the clutch driven disks.

5.5 Gearbox Disassembly and Reassembly

Removing and Reinstalling the Clutch Release Mechanism

(with the gearbox removed from the motorcycle)

To remove the clutch release mechanism, remove the clutch release arm (if need be):

1. Pressing on the front end of the clutch release rod, remove the clutch release slider, the thrust ball bearing, the rod tip and finally the clutch release rod.
2. Wash the disassembled parts and inspect them, change faulty parts as needed.
3. Reinstall the clutch release mechanism in the following sequence.
4. Fit the clutch release rod into its tip, then insert the rod into the hollow in the clutch shaft.
5. Smear the thrust ball bearing with grease and fit it in place.
6. Fit home the clutch release slider, exercising care not to avoid cutting the slider rubber ring against the edge of the gear case.
7. Fit the clutch release arm and lock it with a cotter pin.

Repairing the Clutch Release Mechanism

Proceed with inspection and repairs of the clutch release mechanism, when:

- Dismantling the gearbox in general
- Clutch becomes difficult to engage or release
- Oil weeps through the central hole in the clutch shaft

When inspecting, check:

- The condition of the slider rubber ring
- The thrust surface (case-hardened) of the slider
- The rod tip fitted into the thrust bearing
- Mushrooming or metal transfer at rod tip
- Condition of the clutch release rod oil seal
- Squareness of the rod tip where it thrusts against the pressure plate

Any worn-out or damaged parts must be replaced.

Removing and Reinstalling the Speedometer Drive

Remove the speedometer drive as follows:

1. Undo the bolt of the drive bushing and remove the thrust bushing.
2. Rotating the main shaft counter-clockwise (as viewed from the flexible coupling flange end), remove the driven gear of the speedometer drive.
3. Uncotter the castellated nut of the main shaft, undo the nut and remove the washer and driving flange of the propeller shaft flexible coupling.
4. Wash and inspect the removed parts. Should any of the teeth show wear, replace the gearing. Reassemble the speedometer drive in reverse sequence. Before reinstalling the driven gear, lubricate its face and teeth with grease.

Repairing the Speedometer Drive

Proceed with inspection and repairs, when wear of teeth becomes obvious (the speedometer fails to operate even when the flexible shaft is intact) or in case of dismantling the gearbox in general.

When repairing, change worn-out parts, paying attention to ease of rotation of the gearing and proper backlash in the tothing (with the flexible coupling flange stopped in any position, the driven gear should display a slight side play in the gearing).

Removing the Gear Shift Mechanism (gearbox removed)

The gearbox is disassembled and assembled at ambient temperature. The gear shift mechanism consists of the following assembly units and parts: (Fig. 5.1-5 and 5.1-6).

- Gear change foot pedal mechanism
- Switch quadrant with a shaft
- Reverse gear engagement mechanism with lever
- Gear shift forks
- Bracket with an intermediate gear

The tool required is the crank handle 346-403 for turning the clutch shaft.

For removal of the gear shift mechanism:

1. Unscrew the drain plug and drain oil out of the gear case.
2. Remove the clutch release mechanism.
3. Undo the nut of the kickstarter lever wedge, knock out the wedge with an aluminum hammer, and remove the lever.
4. Turn off two screws fastening the bushing of the kickstarter shaft to the front wall of the gear case and carefully relieve the kickstarter return spring of primary tension.
5. Turn off seven bolts fastening the gear case cover.
6. Hammer slightly the clutch shaft end and the cover projections to force the shafts and rear cover out of the gear case.
7. Remove the flexible coupling flange.
8. Withdraw the gear shift forks shaft from the cover and remove the forks.
9. Take the axle and bracket with an intermediate gear out of the cover.
10. Take the kickstarter shaft together with the gear out of the cover.
11. Press out the clutch and main shafts from the gear case cover by hammering slightly against their end faces.
12. Force out the right-hand cover with the seal.
13. Remove quadrant cotter pin.
14. Turn off the adjusting screws of the gear shift mechanism.
15. Shift the ratchet together with the pawl crank of the gear shift mechanism till the ratchet leaves the left-hand cover, then withdraw the gear shift mechanism with quadrant from the gear case.
16. Undo the nut and remove the reverse gear engagement lever from the axle.
17. Remove the reverse gear engagement quadrant with the shaft and spring.

The mechanism thus removed should be washed and examined. If any damage or defects are revealed, disassemble it, repair and reassemble.

Reassembly of the Gear Case Cover

To reassemble the gear shift mechanism:

1. Place home the gear case cover with the split joint upwards.
2. Set the return spring of the gear shift mechanism by driving the spring ends behind the stop.
3. Fit the spring and the ratchet with the crank (with slider upwards) onto the quadrant square end.
4. Insert the quadrant with its shorter end into the hole in the right-hand cover, then fit the quadrant shaft with the ratchet into the left-hand cover hole bringing the slider between the ends of the return spring being in the cocked position.
5. Drive in the adjusting screws.
6. Fit the right-hand cover with the seal on the shorter journal of the quadrant shaft, force it with the crankcase cover and punch out.
7. Make the quadrant spring thrust against the ratchet face, insert a cotter pin into the hole of the quadrant shaft at the side of free end of the spring; spread apart the ends of the cotter pin.
8. Set the spring on the reverse gear engagement quadrant shaft.
9. Insert the quadrant shaft into the gear case cover hole.
10. Set the reverse gear engagement lever on the shaft splines and secure it.

To reinstall the gearbox shafts:

1. Bring the clutch and the main shafts gearing in mesh and install the shafts in the cover.
2. Press the main shaft into the bearing and bearing N304 on the main shaft.
3. Fit the kickstarter shaft into the cover bringing the gears in mesh.
4. Mount the gear change forks on the shaft, bring the fork lugs into the coupling slots and set the fork shaft in the cover.
5. Set the forks in neutral position and insert their pins into the quadrant slots.
6. Set the bracket with intermediate gear having pressed out the reverse gear quadrant.
7. Insert the shaft into the bracket and in the hole of the cover.
8. Set the reverse gear mechanism into engaged position (the intermediate gear should be in engaged position with the gears).

5.6 Repairing The Gearbox Assembly Units and Parts

Proceed with repairs when dismantling the gearbox in general or there are problems in shifting the gears.

The general view of the gear shift mechanism is shown in Fig. 5.1-5.

Note: When repairing the assembly units and parts of the gearbox, pay special attention to maintaining clearances within the limits set by the Manufacturing Works (refer to Tables 5.6-1 and 5.6-2).

Table 5.6-1 Nominal Sizes, Positive and Negative Allowances Between the Principal Mating Members of the Gearbox. *MEASUREMENTS ARE IN MM*

Part No. & Name	Nominal size & tolerance	No. & Name of mating member (hole)	Nominal size & tolerance	Tolerated limits			
				Positive allowances		Negative allowances	
				min.	max.	min.	max.,
6204201 Clutch shaft	+0.017 25 -0.002	205 Ball bearing	+0.003 25 +0.013		0.001		0.030
6204201 Clutch shaft	+0.017 20 -0.002	12004 Roller bearing	+0.003 20 +0.013		0.001		0.030
Z103-04326 Quadrant Pin	+0.017 20 -0.002	304 Ball Bearing	+0.003 20 +0.013		0.025		0.005
205 Ball bearing	+0.004 52 -0.017	Z103-04101 Gear case	+0.007 52 +0.023		0.025		0.027
304 Ball bearing	+0.004 52 -0.017	Z103-04101 Gear case	+0.008 52 -0.023		0.025		0.027
12204 Roller bearing	+0.003 52 -0.014	Z103-04110 Gear Case Cover	+0.020 48 -0.047			0.006	0.050
6204201 Clutch shaft	-0.017 24 +0.002	7204208-01 Clutch shaft sleeve	-0.016 25 +0.039			0.018	0.056
6204201 Clutch Shaft	-0.017 24 +0.002	Z101-04202 Clutch shaft IV gear	-0.006 25 -0.030			0.008	0.047
Z101-04307 Gear shift fork shaft	+0.025 10 +0.010	Z103-04304/6204306 Gear shift forks	+0.150 10 +0.050	0.025	0.140		
7204119-b Kickstarter shaft front bushing	30 -0.084	Z103-04101 Gear case	+0.045 30	0.000	0.129		

Part No. & Name	Nominal size & tolerance	No. & Name of mating member (hole)	Nominal size & tolerance	Tolerated limits			
				Positive allowances		Negative allowances	
				min.	max.	min.	max.,
Z101-04307 Gear shift fork shaft	+0.025 10 -0.010	Z103-04101 Gear case	+0.150 10 -0.050	0.025	0.140		
Z101-04307 Gear shift fork shaft	+0.025 10 -0.010	Z103-04110 Gear case cover	+0.150 10 -0.050	0.025	0.140		
Z103-04236 Main shaft	-0.040 26 -0.070	6204211,6204212,6 204213 Main shaft gears	+0.033 26	0.040	0.103		
6204306 Gear shift fork	-0.160 6 -0.240	Z103-04222 Gear engaging sleeve	+0.033 26	0.040	0.103		
6204306 Gear shift fork	-0.100 8 -0.200	Z103-04301 Gear shaft quadrant	+0.200 8	0.100	0.400		
6204401 Kickstarter shaft	-0.016 18 -0.033	7204408-b Kickstarter gear	+0.060 18 +0.030	0.046	0.093		
6204401 Kickstarter shaft	-0.016 18 -0.033	7204119-10 Kickstarter shaft front bushing	+0.035 18	0.016	0.068		
6204401 Kickstarter shaft	20 -0.021	Z103-04110 Gear Case Cover	+0.085 20 +0.025	0.025	0.106		
Z103-04236 Main Shaft	-0.040 26 -0.070	6204211,6204212,6 204213	+0.033 26	0.040	0.103		
Z103-04236 Main shaft	-0.040 23.4 -0.070	Z103-04062 Gear 1 assy	+0.033 23.4	0.040	0.103		
Z103-04304 I and II gear shift fork	-0.160 5 -0.240	Z103-04221 I and II gear shift sleeve	+0.160 5	0.160	0.400		
Z103-04304 I and II gear shift fork	-0.100 8 -0.200	Z103-04301 Gear shift quadrant	+0.200 8	0.100	0.400		
6204401 Kickstarter shaft	-0.016 18 -0.030	Z103-04042 Clutch gear assy	+0.027 18	0.016	0.057		
Z103-04305 Intermediate gear bracket	-0.020 18 -0.070	Z103-04061 Intermediate gear assy	+0.027 18	0.020	0.097		
Z103-04248 Bracket pin	-0.020 18 -0.070	Z103-04305 Intermediate gear bracket	-0.070 18	0.020	0.140		
Z103-04248 Bracket pin	-0.020 18 -0.00	Z103-04101 Gear case	+0.070 18	0.020	0.140		
Z103-04248 Bracket pin	-0.020 18 -0.70	Z103-04110 Gear case cover	+0.035 18	0.020	0.105		

Should any problems be revealed, dismantle the mechanism observing the following sequence of operations:

1. Undo the nut fastening the foot pedal shaft, mark the position of the crank arm on the pedal shaft, remove the pawl crank arm and remove the foot pedal; take the ratchet and the crank assy. out of the seat in the gearbox cover and take off the return spring of the gear shift mechanism.
2. Remove the check ring of the ratchet with the help of a metal strip, 1 mm thick, then remove the pawl and the crank from the ratchet hub.

Wash the dismantled parts and inspect thoroughly, paying attention to accurate fitting of pin, pawl axle and tenon. Check the ratchet and pawl for possible defects, also condition of the working edges of the oil seal. Pay special attention to the shift quadrant (check it for wear, cracks, curvatures, etc.). Replace any defective parts.

The pawl should pivot freely on its axle, but without any excessive play. The crank arm and pin should not have play, the maximum permissible clearance between them being 0.6 mm / 0.2 in. The clearance of the ratchet bushing (the hole in the side cover) should not exceed 0.3 mm / .012 in.

Gear shift forks. Having removed the forks, inspect them and measure wear. Table 5.6-2 lists the wear limits for the shift fork parts.

Table 5.6-2. Maximum Tolerated Limit of Clearances and Wear Between the Principal and Mating Members of Gearbox, mm.

<i>Parts and Mating Members</i>	<i>Wear on diameter</i>	<i>Diameter clearance</i>	<i>Axial clearance</i>
Main shaft to main shaft gearing		0.25	
Gear shift fork shaft to shift forks		0.25	
Gear shift forks to gear engaging sleeve (width)			1.00
Gear shift fork (width)	0.40		
Gear shift forkpin to quadrant slot			0.80
Gear shift fork pin	0.20		

To reassemble the gear shift mechanism, reverse the sequence of operations, lubricate the friction surfaces of parts with motor oil. Pay special attention to correct fitting of the return spring and to proper position of the pawl crank arm on the gear change pedal shaft as well as to safe fastening of the shaft nut. When correctly assembled, the return spring should be able to return the foot pedal into the initial position with ease and should have no play in this position.

Repairing the Gearbox Shafts

Clutch shaft. Required tools and fixtures are:

- Puller 345-330-3 for removing the roller bearing cone from the clutch shaft
- Puller 345-441-3 for pressing-out the clutch roller bearing cup

Having removed the clutch shaft from the gearbox, wash it and inspect thoroughly. Check condition of bearings, gear teeth (wear, scores, pitting), the tightness of the 4th gear fit, and condition of splines.

If any defects are revealed, dismantle the clutch shaft as follows:

1. Remove the roller bearing cone.
2. Use tool 139-212-3 to press off the gear.
3. Replace all the defective parts and reassemble in the reverse order.

When pressing in the gear, the bearing and the sleeve, make sure that the gear is fitted with its flat end towards the shaft shoulder. Lay a rubber ring between the bearing and the sleeve. Press in the sleeve with its larger chamfer facing out.

When replacing the roller bearing, be sure to change the race pressed into the clutch shaft rear bearing housing. Use puller 345.441-3 for pressing-out the race. When pressing in the roller bearing race, make sure that its end face with the mark of the Manufacturing Works is facing out. When the clutch shaft is correctly assembled, the dimension measured along the outer faces of both bearings should be within 134 to 133.39 mm / 5.2-5.3 in.

Main shaft. Having removed the main shaft, dismantle it and wash all the parts properly. Check condition of all the parts, paying special attention to the wear of friction surfaces, condition of teeth of the speed gears, as well as those of the gear engaging sleeves. The gear engaging sleeves should travel freely along the main shaft sleeves, and the shaft sleeves should move with ease along the main shaft splines.

Replace any damaged or excessively worn parts. Lubricate the main shaft splines with motor oil, when reassembling. Fit the oil baffles with the bore facing out.

A properly assembled main shaft, should measure 106.74 to 106.264 mm / 4.2 - 4.1 in, along the outer faces of bushings in the assembled set of gears, and 107 to 107.14 mm / 4.2 in between the oil baffles which thrust against the ends of the main shaft.

Kickstarter shaft.

Remove the kickstarter shaft, wash and inspect it thoroughly paying attention to condition of the pawl working edge and the gear ratchet teeth. Rounded edges of the pawl or ratchet teeth may allow the lever to suddenly disengage.

If any defects are revealed, dismantle the kickstarter shaft, as follows:

1. Press out the shaft bushing pin by slightly knocking with a hammer against the end of the protruding portion, remove the shaft bushing, then the gear.
2. Remove the pin and the pawl spring from the shaft;
3. Press out the pawl axle and remove the pawl.
4. Wash all the parts of the shaft and replace worn-out ones. The pawl can be used again by reversing, if the other working edge is still sharp.
5. To reassemble the shaft, reverse the sequence of the operations given above.

Center-punch the pawl axle at both sides in two opposite points. Insert the shaft bushing pin with its thin end on the opposite side of the pawl and press it flush with the bushing. Make sure that once the shaft is reassembled, the gear turns freely on the shaft, and the pawl tooth fits securely into the gear ratchet tooth.

Repairing the Gear Case

Required tools and fixtures are:

- Mandrel 345-336-3 for pressing-out the main shaft bearing from the gearbox cover
- Tool 139-227 for pressing-in the main shaft bearing into the gearbox.

Having dismantled the gear case and the gearbox cover, wash it and inspect, paying special attention to the condition of the main shaft ball bearing, working edge of the oil seal, the quadrant lock in the kickstarter pawl release. Visually inspect the case for cracks and other defects.

Replace any defective parts. When replacing the pawl release, tighten the check screw properly and center-punch in the spline at both sides.

To replace the main shaft bearing, use mandrel 345-336-3 to press it out of the cover and use tool 139-227 to press in the new bearing.

When replacing the lock, press it in the body so that the rear end of the lock body is pressed-in flush with the finished gear case end.

Reassembly of Cover with Gear Case

The tools required for reassembly are

- mandrel 346-298 for pressing the gear case on the cover with shafts
- spanner 36x41.

For reassembly:

1. Install the cover with shafts, with the joint face upwards.
2. Coat a gasket on both sides with gasket cement and place it on the joint face of the cover.
3. Set a washer with a tube and shims in the gear case recess (under the main bearing shaft), then apply grease.
4. Set the pin of mandrel 346-298 in the clutch shaft seal.
5. Place the gear case on the bearings of the clutch shaft and the main shaft and on the fork shaft.
6. Place the gear case on the clutch shaft bearing, the main shaft on the fork shaft, and bracket axle aligning the cylindrical pin with a bracket slot.
7. Align the slot of the gear change foot pedal with the crank pin; by striking slightly with a soft hammer fit the gear case on the bearings, then press the gear case on the press making use of mandrel 346-298.
8. Set and tighten seven bolts fastening the gear case cover
9. Tightening torque of gearcase bolts: 6.4.. .7.8 Nm / 0.65.. .0.8 kgf-m install the gearbox on the cover, fit a rubber ring on the bushing and insert the spring.

10. Fit the bushing with spring on the kickstarter shaft and insert it into the gear case hole, making sure the end of the spring is captured by the bushing pin.
11. Using wrench 36X41 wind the spring counterclockwise by two-thirds of a turn, then align the holes and turn in the screws.
12. Fit the disk on the main shaft splines, fix it and lock with a cotter pin.
13. Set the kickstarter lever on the shaft, insert the lever fastening wedge and tighten up securely by driving it in slowly with a soft hammer, then tighten the lock nut to 15.7... 19.6 Nm / 1.6...2.0 kgf.m.
14. Set the gearshift clutches in the neutral position by turning the reverse gear engagement pedal with the front arm downwards to the limit and check the shafts for ease of rotation.
15. Check performance of the kickstarter and its spring.
16. Axial displacement of the kickstarter shaft up to 1.3 mm / .05 in can be tolerated.

Whenever the gearbox is repaired, it should be run-in at a light load for at least 10 minutes. Be certain the gearbox is filled with oil before running in. Check frequently during run-in for oil leaks, abnormal noises, or local overheating of the neutral position pickup.

Clutch

6.1 Description and Specifications

The clutch is a dry, double disc assembly, operated by a release rod extending through a central hole in the primary ("clutch") shaft. When the clutch release rod is relaxed, springs push the clutch discs together and connect the flywheel to the clutch shaft through splines in the shaft hub. The clutch release rod is controlled by a hand lever on the left grip, connected via a cable to a lever on the back of the gearbox. When the lever is squeezed, the clutch rod is pressed against the pressure plate, the friction plates are separated and power is interrupted between the engine and gearbox. (Figure 6.1-1).

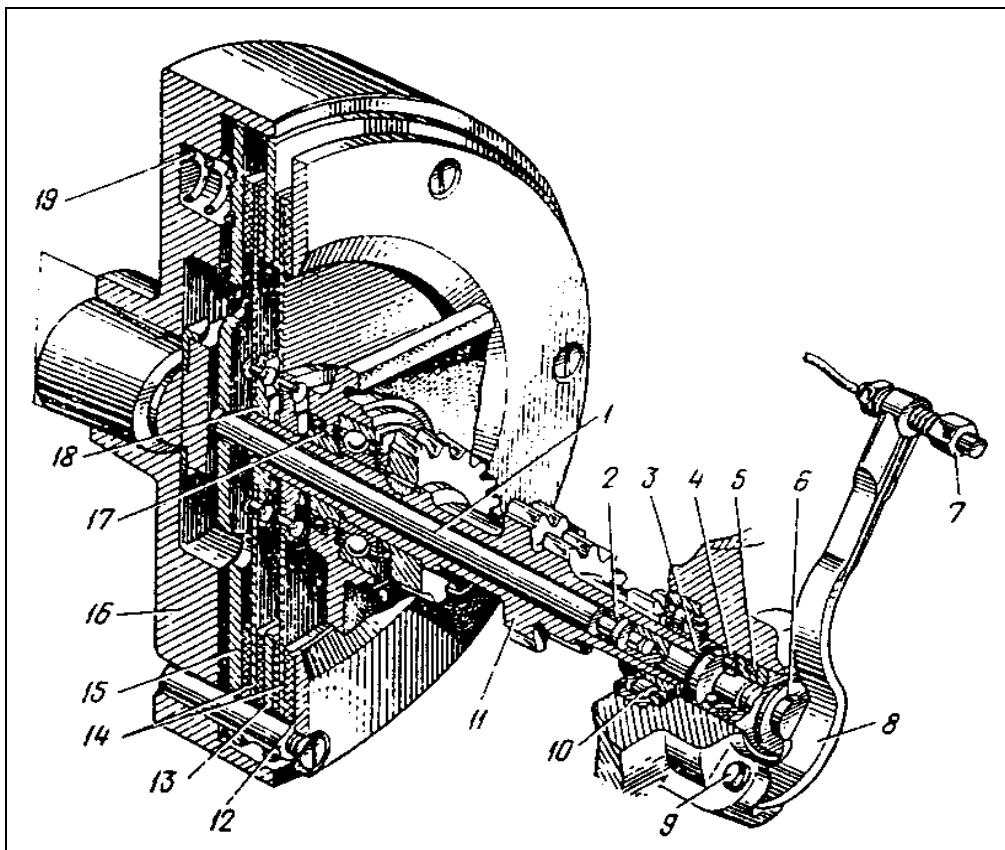

Clutch

Figure 6.1-1.

- | | | |
|-------------------------|-----------------------------------|-----------------------|
| 1 - Release rod | 7 - Adjusting screw | 14 - Driven plate |
| 2 - Rod seal | 8 - Clutch release lever | 15 - Pressure plate |
| 3 - Rod tip | 9 - Lever axle | 16 - Flywheel |
| 4 - Thrust ball bearing | 10 - Clutch primary shaft bearing | 17 - Seal |
| 5 - Slider seal | 11 - Primary shaft | 18 - Driven plate hub |
| 6 - Slider | 12 - Thrust plate | 19 - Spring |
| | 13 - Intermediate driving plate | |

6.2 Clutch adjustment

The clutch control lever (located left of the handle bar) should have approximately 1/4 inch (5 - 8mm) free play, measured at the lever end. The normal play of the lever ensures full engagement and disengagement of the clutch. If there is not enough play, the clutch may slip under load. With excessive play, the clutch may not disengage completely, and the plates will drag. Adjusting screws (7) on the clutch control cable adjust the free play.

6.3 Removing and Reinstalling the Clutch Release Mechanism (with the gearbox removed from the motorcycle)

To remove the clutch release mechanism:

1. Remove the clutch release arm, if required.
2. By pressing on the front end of the clutch release rod, remove the clutch release slider, the thrust ball bearing, the rod tip and finally the clutch release rod.
3. Wash the disassembled parts and inspect them, change faulty parts as needed.

Reinstall the clutch release mechanism in the following sequence:

1. Fit the clutch release rod into its tip, then insert the rod into the hollow in the clutch shaft.
2. Smear the thrust ball bearing with grease and fit it in place.
3. Fit home the clutch release slider, exercising care not to avoid cutting the slider rubber ring against the edge of the gear case.
4. Fit the clutch release arm and lock it with a cotter pin.

6.4 Clutch Repairs

To remove the clutch discs:

1. Insert a screwdriver into the slits of screws fastening the clutch pressure plate and with light blows of a hammer against the screwdriver butt end knock off the metal flashes from the screw slits.
2. Fit tool 345-429-3 on studs and lock with nuts, insert its mandrel into the splined hole of the hubs of the clutch driven disks and by driving in the screw of the tool, apply the clutch.
3. Turn off the fastening screws of the thrust plate.
4. Release the clutch by turning off the tool screw and remove the tool.
5. Remove the clutch disks and springs.

Having dismantled the clutch, wash the parts, inspect and make necessary measurements. Repair or replace worn-out parts.

Proceed with inspection and repairs of the clutch release mechanism, when:

- Dismantling the gearbox in general
- Clutch becomes difficult to engage or release
- Oil weeps through the central hole in the clutch shaft

When inspecting, check:

- The condition of the slider rubber ring
- The thrust surface (case-hardened) of the slider
- The rod tip fitted into the thrust bearing
- Mushrooming or metal transfer at rod tip
- Condition of the clutch release rod oil seal
- Squareness of the rod tip where it thrusts against the pressure plate

Any worn-out or damaged parts must be replaced.

Having dismantled the clutch, wash its parts and check:

- Condition of the working surfaces of the clutch disks
- Condition of splines in the hub of the driven disks
- Riveting of clutch driven disk hubs
- Wear of clutch pins, their proper fitting in the flywheel
- Wear of holes in the clutch driving disks
- Resilience of springs

Repair

If scores or dents are evident, change the clutch disks. When the holes in the intermediate driving disk are worn in excess of 1 mm, bore and ream new holes .48 to .49 in. dia. / 12.5 to 12.53 mm at a spacing angle of 30 degrees to the former ones.

When the wear of the clutch pins exceeds .040 in / 1.0 mm, replace the pins as follows:

1. Press off the worn-out pins.
2. Press in new pins and ensure that they protrude 3.5mm / .14 in above the flywheel rim.
3. Grind the end faces of the clutch pins to 64.5mm / 2.5 in. Check grinding of clutch pin end faces.
4. After repairs, have the flywheel rebalanced.

If the clutch driven disks are worn-out or damaged, remove them and rivet new ones. If the disks are re-usable but the rivets are loose, either replace the rivets or replace the disks.

The clutch springs must be of the same color marking. The springs are marked during manufacture. Clutch spring free length should be a minimum of 1.9 in / 43 mm. When compressed to .83 in / 21 mm, the springs should achieve loads rated by the color marking on the spring ends as follows:

N (kgf):

gray 170... 186 (17.5... 19)

black 157... 170 (16... 17.5)

6.5 Clutch Reassembly

Insert the springs of the same color marking into the respective flywheel sockets:

1. Fit the clutch pressure plate on the flywheel pins and make sure that the thrust planes of the springs have entered the respective recesses of the pressure plate.
2. Fit the guiding pins after every second flywheel pin and reinstall -- observing the given sequence - the clutch driven disk, the intermediate plate, the clutch driven disk and the thrust plate.
3. Fit the splined mandrel of the tool having matched the holes in the driven disks and the clutch pressure plates.
4. Fit the tool 345-429-3 and by driving in the screw of the tool compress the springs (Fig. 11).
5. Remove the guiding pins.
6. Having matched the holes in the thrust plate with the flywheel pin holes, turn in the screws fastening the thrust plate. Tighten the screws in a criss-cross manner;
7. Loosen the tool screw and remove the tool. Punch each screw at two points drawing the disk metal into the screw slits. After that, take off the splined mandrel.

Drive Shaft and Final Drive

7.1 Description and Specifications

Power is delivered from the gearbox to the rear wheel by a drive shaft ("propeller shaft") and final drive with bevel gears. The drive shaft is connected to the gearbox via a flexible rubber collar that helps dampen torque impulses and a universal joint to allow suspension travel of the rear wheel (Figure 7.1-1).

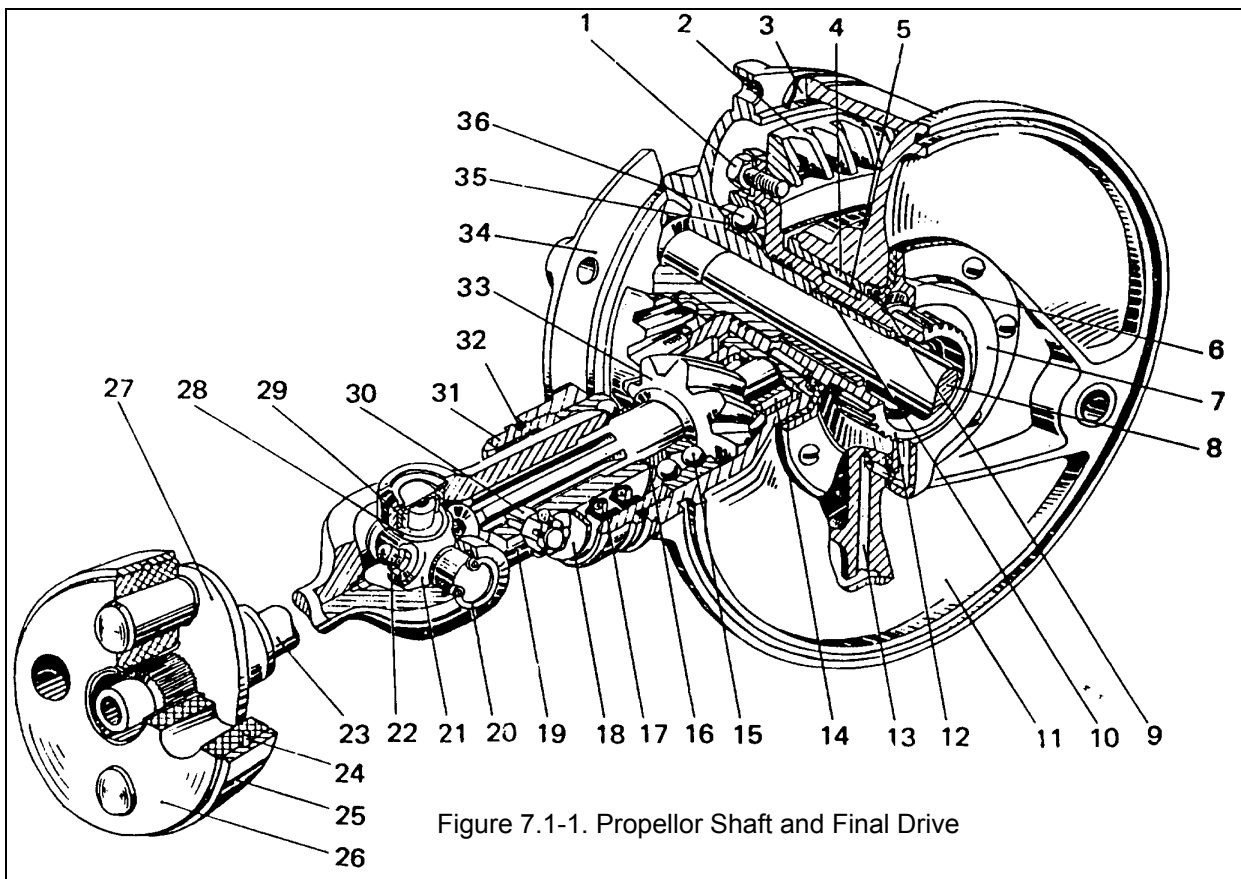

Figure 7.1-1. Propellor Shaft and Final Drive

- | | | |
|--------------------------------|-----------------------------------|---------------------------------|
| 1 - Driven gear fastening bolt | 13 - Oil drain duct | 25 - Hood |
| 2 - Driven gear rim | 14 - Needle bearing | 26 - Propeller shaft collar |
| 3 - Gasket | 15 - Double-row ball bearing | 27 - Flexible joint driven disk |
| 4 - Crankcase bushing | 16 - Adjusting washer | 28 - Packing ring |
| 5 - Needle bearing roller | 17 - Universal joint fork seal | 29 - Needle bearing |
| 6 - Casing seal | 18 - Protective washer | 30 - Wedge belt |
| 7 - Seal cover | 19 - Universal joint splined fork | 31 - Bearing nut |
| 8 - Rear wheel axle | 20 - Lock ring | 32 - Gasket |
| 9 - Seal spring | 21 - Universal joint cross | 33 - Driving gear |
| 10 - Distance bushing | 22 - Grease cup | 34 - Casing cover |
| 11 - Casing | 23 - Propeller shaft | 35 - Adjusting washer |
| 12 - Driven gear hub | 24 - Lock ring | 36 - Ball bearing |

The final drive is a cast housing containing a helical bevel gear set that turns the rear wheel at a lower speed than the shaft. The casing also serves as a backing plate for the brake shoes, an oil reservoir and a support for the right-hand end of the rear wheel axle. The casing has an oil drain hole at the bottom that is blanked off with a plug. Cover (34) attached to the casing has a slot and two studs used to fasten the whole drive to the swinging fork arm of the rear suspension. A fill hole is provided in the cover.

Gear backlash is adjusted via adjusting washers (35) installed between the side portion of casing cover and the inner race of ball bearing (36). For proper performance of the drive a .004 in. / 0.1 to 0.3 mm backlash is necessary between the active faces of gears.

Maintenance of propeller shaft and final drive. The daily maintenance involves tightening the nuts which fasten the final drive to the swinging fork arm. Failure to tighten the nuts in due time results in loose joints and destruction of the final drive cover.

Every 5,000 km change oil in the final drive casing. Refilling requires 0.23 pints of premium grade automotive EP gear oil, SAE 80 or 90.

Every 10,000 km, lubricate the needle bearings of the universal joint cross. Dismantle the final drive and using a grease gun stuff grease into the cross through the grease cup.

7.2 Removal and Installation of Final Drive

To remove the final drive together with the propeller shaft:

1. Set the motorcycle on the center stand and remove the rear wheel.
2. Slacken off the wing nut of the rear brake tie-rod and disconnect it.
3. Unfasten the nuts from the studs fastening the final drive to the swing arm.
4. Detach the final drive from the swinging fork arm and pull it straight back.
5. Remove the flexible joint flange off the propeller shaft to facilitate its passing through the hole in the swinging fork girder.

To reinstall the final drive, reverse the sequence of operations.

7.3 Removing and Reinstalling Propeller Shaft

To disconnect the propeller shaft from the final drive proceed as follows:

1. Uncotter the nut of the wedge bolt, unscrew the nut and using a soft mandrel knock the wedge bolt out.
2. Remove the splined fork of the shaft from the driving gear shank (by slightly knocking with a soft hammer).
3. Having disconnected the propeller shaft, wash it and inspect, paying particular attention to the universal joint. The bearings should rotate with no resistance or excessive play. If necessary, dismantle the universal joint.

7.4 Removing and Reinstalling the Rear Swing Arm

(rear wheel and final drive removed)

To remove rear swing arm:

1. Undo top and bottom bolts securing shock absorbers and remove them.
2. Unbend the tabs of the "shakeproof" lock washers at the swing arm pivots and screw out the pins.
3. Pull the swing back, and turning it, take it out of the frame.

Reinstall the rear suspension by reversing the sequence of the operations given above. When mounting the swing arm, tighten up the silent blocks fastening pins with the swing in the middle of it's arc (the swing arm should be positioned parallel to the bottom tubes of the frame). Reinstall the spring-loaded hydraulic shock absorbers.

The tightening torque of the pins is 55 foot/pounds / 75 Nm.

Tightening torque of the shock absorber bolts is:

- Top: 20 foot/pounds / 27 Nm
- Bottom: 30 foot/pounds / 40 Nm

7.5 Driveshaft and Universal Joint Repair

Dismantling and reassembling the universal joint (with the propeller shaft disconnected from the final drive). Refer to Figures 7.5-1, 7.5-3.

To dismantle the universal joint:

1. Remove the lock rings from the propeller shaft holes and from the splined fork (for the universal joint cross pins).

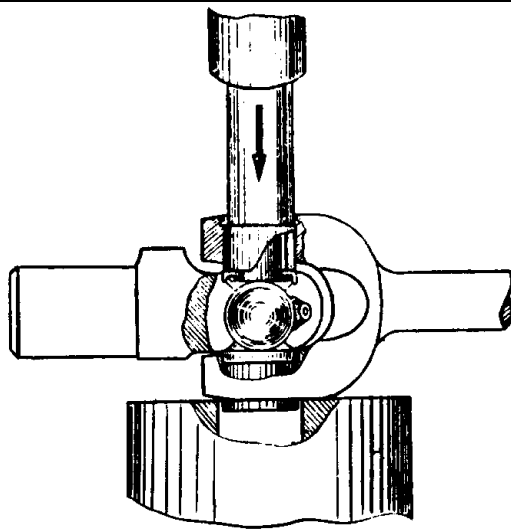

Fig. 7.5-1. Pressing out of the needle bearings

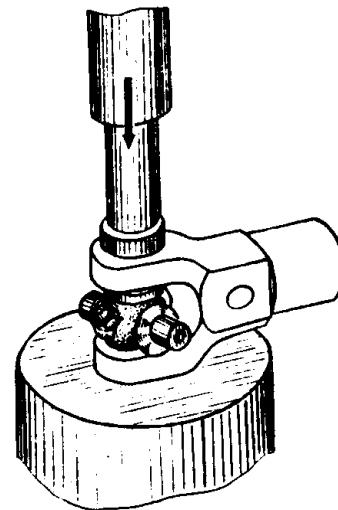

Fig. 7.5-2. Reassembly of the universal joint

2. Lay the fork on the hand press and press out one of the needle bearings, until the universal joint cross thrusts against the fork. The opposite needle bearing cap will protrude partially out of the fork.
3. Clamp the protruding portion of the bearing in a vice and remove it.
4. Turn the propeller shaft and press out the second needle bearing out of the fork from the opposite side through the cross.
5. Take the holders and rubber sealing collars from the universal joint cross and separate the universal joint from the propeller shaft.
6. In the same manner, press out the needle bearings from the propeller shaft splined fork, take out the holders and sealing collars, then remove the universal joint cross.

Inspect all the parts carefully, paying special attention to the mated friction surfaces.

Check the condition of:

- The flexible joint coupling
- The propeller shaft splines
- The universal joint cross needle bearings

Reassemble the universal joint as follows:

1. Smear the inner surfaces of the needle bearings with grease and pack the needles into the bearings.
2. Turn the grease nipple into the universal joint cross, inserting it into the splined fork of the universal joint with the pins with the grease nipple facing out. (Fig. 7.5-2).
3. Fit the rubber sealing collars and holders on the inserted pins of the universal joint cross.
4. Press in the needle bearings. Ensure that the universal joint cross pin enters the bearing without disturbing the needles and that the bearing is fitted not deeper than required for installation of the lock ring, to prevent the cross being gripped by the bearings.
5. Fit on the lock rings.
6. Fit the propeller shaft on the second pair of the cross pins, fit on the sealing collars and holders in the same sequence, press in the bearings and mount the lock rings.

When reassembling the propeller shaft, pay special attention to the joint of the splined fork to the pinion gear shank. The slot in the pinion gear shank is tapered to allow tightening with the wedge bolt. Therefore, when fitting the splined fork on the shank, assemble the parts so the wedge hole tapers match. Insert the wedge bolt from the side of the boss with the shear facing the shank end. With the nut tightened up, the wedge bolt head should not sink in the boss. If the bolt head sinks too far into the boss, add thicker shims between the splined fork and the ball bearing. The tightening torque of the wedge bolt is 65 ft/lb. / 8.82 Nm.

7.6 Final Drive Disassembly (with final drive removed from motorcycle)

Dismantling and Reassembling the Final Drive
(with the propeller shaft removed) Refer to figure 7.6-1.

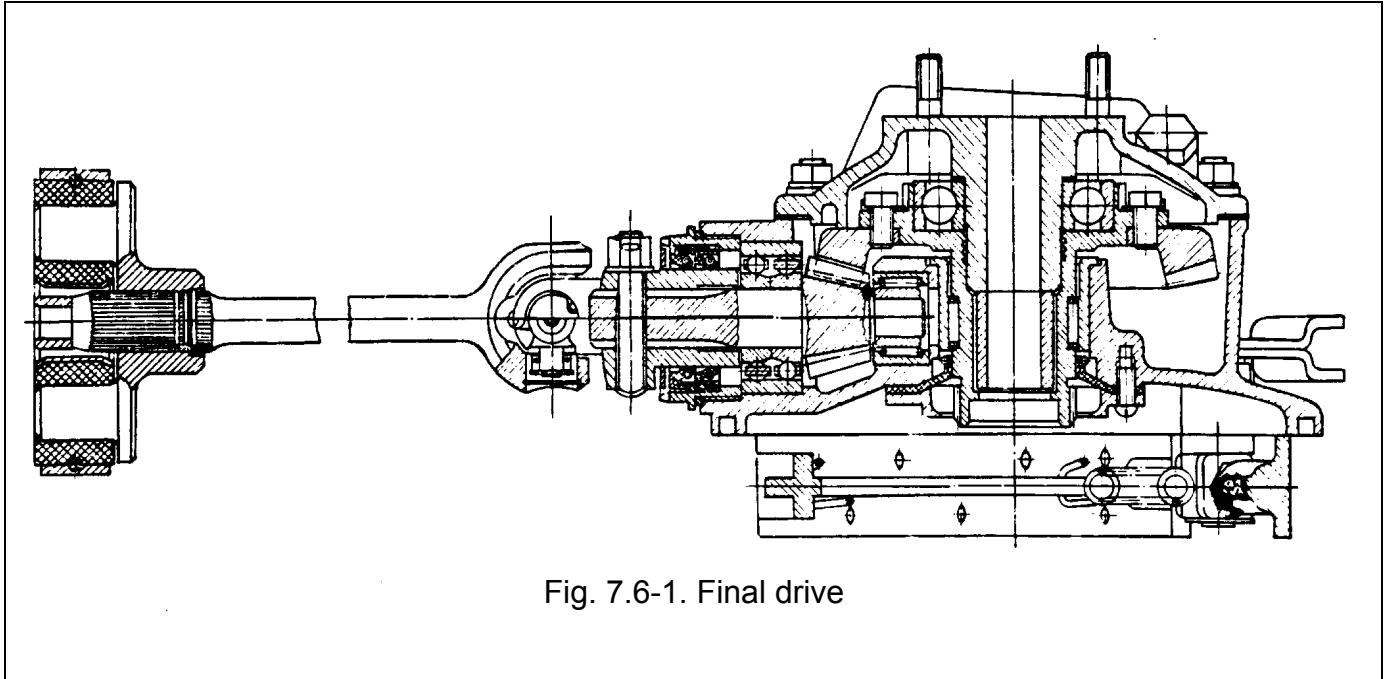

Fig. 7.6-1. Final drive

Required tools are:

- Replacer 345-320-3 for removing the radial ball bearing of the pinion
- Puller 345-325-3 for removing the needle bearing inner race from the pinion
- Mandrel 345-810 for mounting the collar seal

To dismantle the final drive:

1. Remove the brake shoes.
2. Drain gear oil, fill the housing with kerosene or solvent, and wash the inner cavity by rotating the drive in both directions. Drain the solvent.
3. If it is necessary to remove the brake lever, mark the position of the lever on the brake cam before removing. Unscrew the nut fastening the brake cam lever and by knocking slightly with a soft hammer, drive the cam axle out of the arm. When reassembling, ensure that the brake lever is installed at 33 degrees angle back from the vertical centerline of the final drive.

Note: Before dismantling the drive for repairs, measure the backlash in the bevel gear pair which should be within 0.10 to 0.30 mm.

4. Turn out the screws fastening the seal cover, remove the cover and the rubber seal collar together with the spring.

5. Unscrew the nuts fastening the casing cover, remove the washers and by slightly knocking against the end of the driven gear hub, remove the cover together with gasket and the driven bevel gear in assembly with the hub.
6. Remove the rollers from the hub groove (45 rollers).
7. Remove the hub with the driven gear from the casing cover, inserting the rear wheel axle into the central hole until the hub rests against the distance bushing and holding the hub by hand, knock slightly against the axle end to press the cover from the bearing.
8. Press the ball bearing from the driven gear hub through the holes in the gear using a drift for the purpose. Take care to keep the bearing from cocking, when removing.
9. Unscrew the nut fastening the pinion gear bearing by turning it clockwise (left-hand thread) and remove the sealing ring.
10. Insert the wedge into the pinion gear shank slot, remove the pinion gear together with the radial-thrust ball bearing, remove the packing and adjusting washers.
11. Take the needles out of the bearing on the pinion shank.

7.7 Repairing The Final Drive

With the final drive disassembled, inspect the parts and measure the mating surfaces. By visual inspection, determine the condition of:

- threaded joints (for damage to thread, rigidity of the joints)
- oil seals
- casing bushing, that serves as outer race for the roller bearing of the driven gear hub
- side surfaces of the distance bushing
- race of the roller bearing and the teeth of the driven gear hub meshing with the wheel hub
- ball bearings
- Bevel gearing teeth (wear, pitting, crumbling of the working surfaces of the teeth). Pay particular attention to the wear pattern of the gear teeth. If the gears have damaged teeth, both pinion (final drive driving gear) and bevel (final drive driven gear) should be replaced as a matched set, and meshing adjusted. Gear sets are selected and run-in by pairs to ensure quiet operation.

Table 7.7-1 lists tolerated wear limits of parts related to the final drive. Parts worn beyond the recommended limits should be replaced. It is a wise precaution to replace all seals and gaskets.

Table 7.7-1. Maximum tolerated limits of clearances and wear between the principal mating members of the final drive and the propeller shaft, mm

Name of parts and mating members	Maximum tolerances		Measuring point and method
	wear on diameter	diameter clearance	
Ring gear hub splines	Tooth thickness 0.75		
Propeller shaft cross pins (journal)	0.05		On working surfaces of journals
Final drive gears	Tooth thickness		
Ring gear hub bearing	0.15	0.12	

When replacing the bevel pinion and in order to remove the bearings, make use of remover 345-325-3 for the needle bearing inner race and replacer 345-320-3 for the radial thrust ball bearing. To press out the outer race of the needle bearing from the casing, heat the bearing to a temperature of 180 F / 75 to 90 C. Begin by pressing-out the bushing which serves as the outer race of the driven ring gear hub and then knock out the needle bearing outer race through the hole thus opened up.

Reverse the sequence of the operations, when reassembling the final drive. Prior to mounting the needles into the bearings smear the fitting points with lithium bearing grease to keep the needles from falling out when reinstalling the mating members.

The tightening torques:

- casing cover nuts 11 ft/lbs / 13.7 to 17.6 Nm
- pinion bearing nut 55 ft/lb. / 68.6 to 88.2 Nm

To fit the rubber seal on the driven gear hub use mandrel 345-810.

Having completed the repairs and reassembled the final drive, check the gearing backlash and tooth contact. Backlash should be between .003 and .006 inch (0.07 to 0.16 mm). adjust it, if necessary, by inserted shims between the driven ring gear hub ball bearing and the casing cover wall and between the pinion and bearing in special situations.

Backlash and gear mesh adjustment

The following is a general procedure for final drive units of this type:

NOTE: Before proceeding, allow the case and the bearing to cool down to shop temperature. If they are still hot it will give a false reading.

1. With the ring gear installed in the case and into mesh with the pinion drive gear.
2. Attach a clamp to hold the pinion shaft securely so that it can't rotate in the case.
3. Temporarily attach a strap of metal to the output spline, leaving a short tab extending on a radial.
4. Secure a dial indicator on the case, pointing perpendicular to the tab.
5. Adjust the dial gauge to zero.
6. Gently rotate the ring gear back and forth through the limit of lash, and note the dial gauge reading.

Final drive gear backlash should be within 0.003 to 0.006 inch / .07 to 0.16 mm. If the backlash is incorrect, change the adjusting shims on the ring gear, substituting thicker or thinner shims to achieve backlash within tolerance.

If new gears or pinion bearings have been installed, gear tooth contact should also be checked:

1. Remove the ring gear and smear a coating of gear marking compound on several of the pinion teeth (lipstick can be used for this purpose).
2. Install the ring gear again. Pushing the ring gear towards the pinion, rotate the gears through several teeth to transfer the marking compound onto the other gear teeth.
3. Remove the ring gear and observe the pattern left on the teeth of the pinion.

The ideal wear pattern is with contact centered in the middle of the pinion tooth surface. If the contact pattern is towards the edges of the pinion tooth, the pinion shaft should be moved in or out of the case by changing the shim to a thicker or thinner shim.

When backlash and tooth pattern is acceptable, remove all traces of the gear marking compound and assemble the final drive.

Refer to section 7.8 for description of and repair of final drive for the Sportsman & Patrol Model Driven Sidecar Wheel.

7.8 Final Drive with Driven Sidecar Wheel

To disassemble the final drive (model with differential):

1. Remove the two bolts attaching the propeller shaft fork to the sun gear flange and move the fork in the direction of the side-car giving access to the rear wheel axle nut.
2. Remove the wheel.
3. Remove the brake shoes.
4. Drain out the oil from the main drive gear case.
5. Remove the collar and the cover.
6. Remove the gear case cover nuts and remove the cover together with the gasket.

Differential body and gears:

1. Remove the nut from the cover together with the sun gear and seal.
2. Tap lightly to remove the differential body with seal from the cover.
3. Remove the epicycle gear with two sets of rollers and seal and spacer from the case.
4. Remove the driven conical gear with the hub.
5. Remove the needle rollers from the splines in the hub in the gear case.
6. Proceed further as described for the standard (single wheel drive) final drive assembly.

Before tightening the nut in the case cover, the sun gear flange with seal and ball bearing should be installed. The bronze ring should be positioned onto the sun gear neck next after the steel ring. After putting the main drive together, check and adjust the side play of the conical gears by tightening or loosening the nut in the case cover. When side play of .004 to 0.010 inch / 0.1 to 0.3mm is achieved, stop adjusting and fix the nut with the retainer.

Repair of the sidecar wheel shaft and drive (refer to Sidecar section)

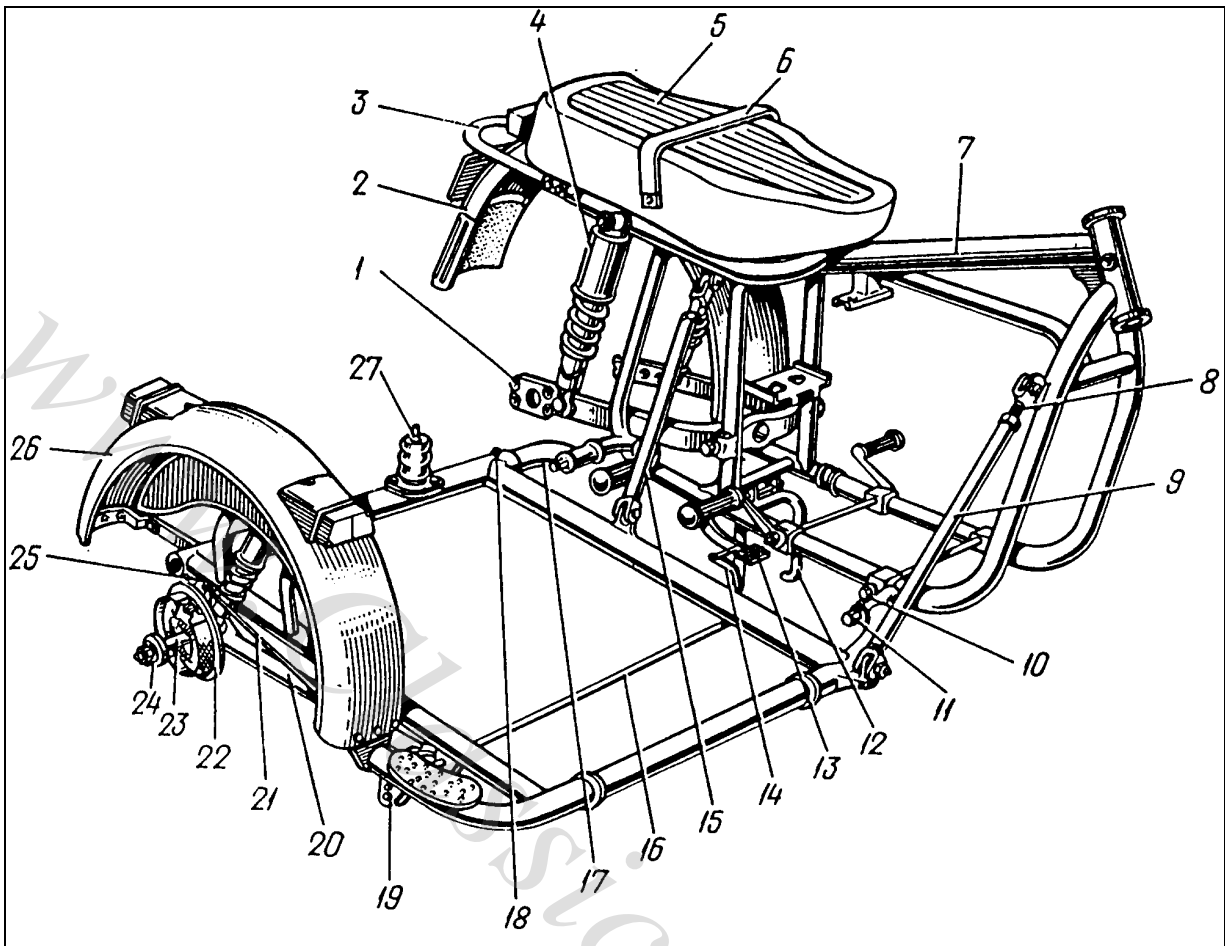

Figure 23. Motorcycle and Sidecar Frames

- | | | |
|--|----------------------------------|---------------------------------------|
| 1 - Rear suspension swinging arm | 10 - Collet clamp | 20 - Lever |
| 2 - Rear mud shield | 11 - Collet clamp screw | 21 - Brake tie rod |
| 3 - Rear grab bar | 12 - Motorcycle stand | 22 - Brake drum cover |
| 4 - Spring-loaded hydraulic shock absorber | 13 - Brake pedal | 23 - Sidecar wheel axle |
| 5 - Seat (Saddle or Tractor) | 14 - Sidecar wheel brake lever | 24 - Protective hood |
| 6 - Strap | 15 - Sidecar frame legs | 25 - Tie rod nut |
| 7 - Motorcycle frame | 16 - Sidecar wheel brake rod | 26 - Sidecar wheel nut fender |
| 8 - Leg adjusting fork | 17 - Rear collet clamp bracket | 27 - Rubber member of body suspension |
| 9 - Sidecar frame legs | 18 - Rear bracket fastening bolt | |
| | 19 - Lever pins | |

NOTE: For further description of the URAL® driven sidecar wheel, see section 3.8.

Electrical

8.1 Description and Specifications

The electrical equipment of the motorcycle includes power supplies, auxiliary instruments, horn, lights, ignition, and electric wiring. Electric power is supplied from a storage battery and an alternator with a built-in voltage regulator. A single-wire negative-ground system is employed for wiring the electric circuits. (i.e. A single wire runs from the electric power supplies to the electric loads from the positive terminal of the storage battery and the alternator, with the frame and other metal parts of the motorcycle serving as the ground.)

The Interstate YTX20L-BS storage battery supplies electric power when the engine is not running.

The negative terminal of the storage battery is connected to the ground through the main switch, underneath the seat. The BK57 ground switch serves to disconnect all electrical loads from the storage battery for long-term parking. The switch is located above the storage battery.

The electrical connections are subject to corrosion, even on new machines. Any electrical circuit problems should be traced down and solved. Often, the problem is simply an oxidized electrical connection which can be solved by scraping the metal clean and applying an anti-oxidizing lubricant such as petroleum jelly.

8.2 Maintenance and Troubleshooting

During the daily preventive inspection, check the functioning and the condition of the electrical equipment. After every 10,000 km, replace the spark plugs. The gap is readjusted by bending the end of the side electrode. Check also the condition and connection of the spark plug wires.

Care of Alternator

In the course of daily inspection, check the wire insulation and electrical connectors, especially alternator battery terminal connections. Also check fastening of the alternator on the engine crankcase. With the engine running, listen for correct backlash of the alternator drive gears.

Every 10,000 km run, check for proper tightening of the battery terminal connections.

At least once monthly, check the charge of the storage battery. If it is low, recharge overnight with a 2A charger.

Every 20,000 km, clean the alternator cover cavity at the slip rings end. Then blow through the alternator with compressed air to remove brush and copper dust.

www.ClassicCycles.org

8.3 Battery

Battery Maintenance

Keep the battery clean in service and lightly coat terminals with petroleum jelly or battery terminal lubricant to prevent corrosion. Do not over tighten terminal connections. The battery case can be cleaned with a solution of baking soda in water, which will help neutralize any acid residue.

CAUTION: When cleaning a battery, temporarily close off the vent hole to prevent any cleaning solution from contacting the acid inside the battery. For charging, the vent hole must be open to allow release of explosive hydrogen gas.

Once a new battery has been filled with battery acid, use only distilled water to maintain the normal level of electrolyte. In service, do not top up the level or the density of electrolyte by adding acid.

Coat bolts, nuts, washers and wire terminals with petroleum jelly or acid-resistant battery grease.

Use two wrenches for clamping or undoing the nuts to avoid breaking internal battery connections.

Do not allow the battery to remain discharged for more than 24 hours. Prolonged discharging will cause permanent sulfation of plates. A discharged battery will freeze and crack if left exposed to sub-freezing temperatures.

WARNING: Batteries contain sulfuric acid which if spilled on skin will cause severe burns. Avoid contact with clothing, skin, and especially eyes. Always protect hands and protect eyes with shield or goggles when adding acid to a new battery, or when topping up electrolyte.

Acid ANTIDOTE: External – flush with water. INTERNAL -- drink large quantities of water followed by milk of magnesia, vegetable oil or beaten eggs. Call doctor immediately.

WARNING: Batteries constantly produce explosive hydrogen gas, especially when being charged. Keep cigarettes, open flame, and sparks away from the battery at all times. Ventilate the area when charging a battery. Never attempt to test for battery voltage by arcing a wire between the negative and positive posts.

CAUTION: If the battery is filled above the upper mark, some of the solution will be forced out through the vent tube when the battery is charging. This will not only

dilute the electrolyte, but will corrode anything near or under the vent tube. To prevent battery case damage and possible explosion caused by pressure build-up, be sure the vent tube is properly routed and not kinked or obstructed when it is installed on the motorcycle.

New Battery Storage

Store new batteries dry, at temperatures no lower than 50F / 10C, or higher than 80F / 27C, for no longer than two years, with plugs screwed in tightly and with gas discharge ducts closed off.

Ural will warranty dry charged batteries for 90 days in service, providing the New Battery Storage limits are observed and that the following New Battery Preparation and Battery Charging procedures are followed for activating a battery.

New Battery Preparation

Prior to initial charge:

1. Remove the plugs unit from the battery and cut off the sealing projection (lug).
2. Fill the battery cells with battery acid, and let sit for 20 minutes to allow electrolyte to saturate the plates. Top up with acid as needed, to maintain upper level line in each cell.
3. Start charging no sooner than 20 minutes, but no later than 2 hours, after filling with electrolyte.

Battery Charging (new or used batteries)

CAUTION: When charging the battery, disconnect the positive terminal (+) from the battery to prevent damage to the electrical components. **Never jump-start a motorcycle.

CAUTION: Do not attempt to charge a battery with frozen electrolyte. Remove the battery from the motorcycle, place it in a plastic container to catch any spilled electrolyte, and allow the battery to warm to room temperature for at least 1 hour. Ensure that there are no cracks in the case and no electrolyte leaks, before attempting to charge.

Use a 12 volt trickle charger (2 Amp 12V DC) for charging, preferably an automatic charger that will adjust charge rate to battery state.

Ensure electrolyte is filled to top level before charging.

While charging, monitor battery temperature and electrolyte level. Check that the battery temperature during charging is not higher than 112 F / 45°C, (obviously warm to the touch, indicating too high a charge rate.)

Charge with 2 A current until gassing is evident in all the cells.

Continue charging for 30 min. to ensure complete mixing of electrolyte, then disconnect the charger and let the battery sit for 30 min.

Check the level of electrolyte after charging and top up as needed with distilled water only.

Note: At full charge, all cells should show vigorous bubbling ("gassing"). If one cell appears quiet or boils off electrolyte, it indicates a cell problem such as sulfation, broken plate connections or shorting of plates, in which cases the battery should be replaced.

After charging, wipe the battery with a damp rag, then wipe dry. Reinstall the plugs. Scrape the contact areas of the posts to bright lead, and coat the posts, bolts, washers and nuts with commercial battery grease or petroleum jelly. The battery may now be installed in the motorcycle.

Removing or Installing the Battery

- Remove the saddle.
- Disconnect the wires from the battery terminals.
- Undo the nut which holds the battery fastening band and remove the battery.

Reinstall the battery in the reverse sequence. Clean the terminals and apply acid-proof grease to the connections to help prevent corrosion in service.

CAUTION: To prevent short-circuiting the battery, always disconnect the negative terminal first, then the positive terminal. When connecting, attach the positive terminal first, then the negative terminal. To protect the battery posts from breaking off, always hold the terminal bolt with a wrench when unscrewing the nuts. Use caution to prevent dropping a wrench across the battery terminals.

Storage of batteries during lay-up

The batteries mounted on a motorcycle during long term suspensions in service or winter lay-up should be kept charged and the electrolyte level monitored every month.

Before lay-up:

1. Fully charge the battery.
2. Replace the plugs, wash the battery surface with a baking soda/water solution and wipe dry.
3. Clean the bolts and nuts of dirt and oxidation and lubricate with acid-resistant battery grease.

Note: The easiest method to maintain the battery is to attach an automatic trickle charger which can be left attached to the battery full time during lay up.

Battery Testing

When there is a question about the suitability of a used battery for further service or whether an electrical problem is being caused by the battery or the charging system, the battery should be checked for ability to accept and hold a full charge.

Before testing a storage battery, clean and charge it. The battery to be tested should be fully charged, either having been recently run on the motorcycle, or via the Battery Charging procedure. Visually inspect the battery for possible electrolyte leaks, especially from cracks in the cells, check good connection of the battery posts and check that electrolyte level remains at the top mark in each cell. Test the battery with a hydrometer.

Warning: Battery acid is corrosive, and will burn skin rapidly. When handling batteries, especially when taking electrolyte readings, protect your eyes, skin, and clothing. If any acid should be spilled, wash it off quickly with soapy water. If electrolyte should splash in your eyes, IMMEDIATELY flush your eyes with copious quantities of clean water and seek medical attention.

ClassicCycles.Org

8.4 Alternator

The alternator with built-in voltage regulator is turned by the engine camshaft driven gear. The field is excited by battery voltage. The alternator is rated at 14V, 35 Amps. Actual output is electronically regulated and nearly independent of alternator rotation speed. Alternator is a negatively grounded unit.

The alternator is secured with two studs on the engine crankcase. The alternator cover has eccentric mountings that allow mesh adjustment of the drive gears. The transmission ratio between the engine crankshaft and the alternator shaft is 1:1.33.

The internal electronic voltage regulator controls alternator output voltage. The voltage regulator requires no maintenance. The regulator is rated at 14V, 35A, maintaining maximum voltage to between 13.5 to 14.5 V.

Alternator Testing

If the battery is good, but the alternator is unable to maintain full battery charge at constant road speeds, the alternator and alternator wiring should be inspected and tested.

Before conducting alternator tests, ensure that the alternator wiring is intact, and that wire connections are clean and tight, especially at the battery. Be certain that the alternator has a good ground to the engine, and that the alternator light illuminates when the ignition is switched on. If all the wiring connections appear to be correct, but the alternator does not appear to have sufficient output, test the alternator.

The alternator can be tested on the motorcycle. Start the engine, and while the engine is running, remove the positive wire from the battery. If the motor instantly dies, then the alternator is defective. Other than worn slip ring brushes, it is probably more economical to replace the alternator than attempt to repair it. It is advisable though, to check for obvious problems such as a broken wire or brush spring.

CAUTION: When running the engine with the motorcycle stationary, use a cooling fan in front of the cylinders to help keep the engine from overheating.

Warning: Use adequate ventilation of exhaust fumes to prevent carbon monoxide poisoning. Do not run the engine in a closed space, even for just a few minutes.

To remove the alternator:

1. Disconnect the negative wire from the battery terminal.
2. Disconnect the wires from the alternator output terminal and the alternator fault light connector.
3. Undo the nuts fastening the alternator and remove the alternator by shifting it to the rear.

To reinstall the alternator, reverse the sequence of the operations.

After installing the alternator, it must be adjusted for correct mesh of the drive gears:

1. Rotate the alternator clockwise to the stop (as viewed from the rear) then rotate it back .12 - .15 in / 3 to 4 mm (measured at the outer diameter of the alternator frame).
2. Secure the alternator in this position. Check the proper clearance by starting the engine and listening to alternator gear mesh. Stop the engine, rotate the alternator slightly, secure it, and start the engine again. With incremental adjustments of the alternator position, the gear noise may be minimized, which is the correct position for operation.

Alternator Repair

The brushes should contact the slip rings over at least 80 % of their working surfaces and should be free from chips. Chipped brushes or brushes worn to 10 mm or less should be replaced. The slip rings may be resurfaced, if there is sufficient material left.

Note: A shiny smooth film on the surface of slip rings is a sign of normal performance, and need not be removed.

8.5 Ignition

IGNITION SYSTEM

The ignition system incorporates the power supplies, ignition coil, moving coil pickup, electronic amplifier, two spark plugs, a set of low and high voltage wires and the ignition switch.

A contactless ignition system with electronic ignition timing is used.

The ignition coil has two high voltage terminals, each supplying one of the cylinder spark plugs and operating in conjunction with the moving coil pickup.

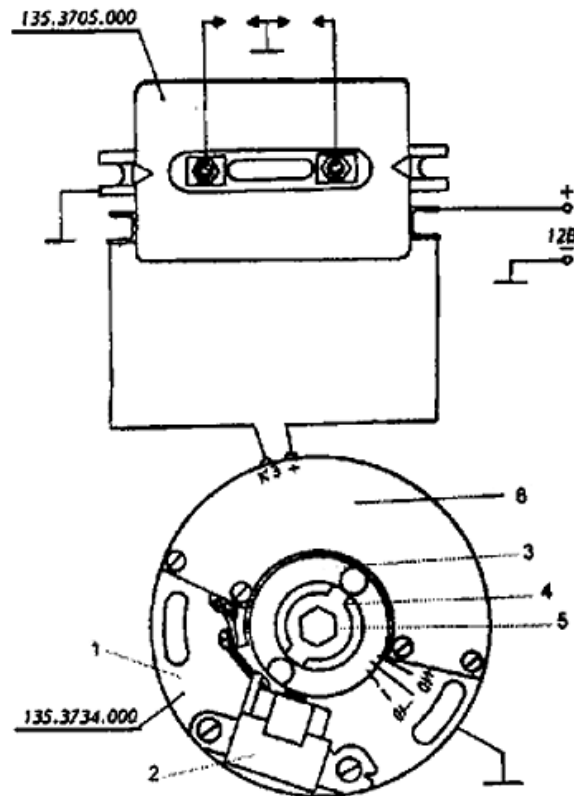

Figure 12. Moving Coil Ignition Pickup

- | | |
|------------------|--------------------------|
| 1 - pickup base | 4 - rotor carrier |
| 2 - pickup | 5 - bolt |
| 3 - pickup rotor | 6 - electronic amplifier |

Periodically, check all wires to be sure they aren't crimped or have loose connections.

The ignition system incorporates the power supplies (storage battery and alternator), low voltage wiring, main switch, ignition coil, contactless timing sensor, electronic amplifier, high voltage wires and spark plugs. See Figure 8.1-1.

The contactless ignition system (BC3) with electronic ignition timing is interchangeable with the mechanical points/coil system which is no longer available from the factory. All current models use the BC3 ignition.

The system consists of a moving coil pickup and the electronic amplifier module located on the engine.

Ignition timing

Since ignition timing is accomplished by a magnetic pickup, timing should not require adjustment in the normal course of operation. However, if timing is disturbed by repair work, it should be checked. Timing is adjusted by moving the position of the pickup coil, as follows:

1. Using either the kick starter or rotating the rear wheel in 4th gear, match the first arrow (with the point) on the flywheel with mark M3 on the engine crankcase.
2. Slacken the screws fastening the pickup base and turn it so that the mark on the pickup rotor matches mark "0" on the pickup base, then tighten the screws.
3. Check the gap between the rotor and the moving coil pickup, and adjust if required. Pickup coil gap should be .008 to .012 in. / 0.2 to 0.3 mm.

Note: If the rotor mark is not visible after matching the flywheel mark with M3, the crank is on the wrong stroke. Turn the crank through 1 revolution and check the pickup rotor again.

Automatic timing advance can be checked with an inductive strobe light, after making suitable marks on the flywheel:

Engine speed	Speedo MPH in 4th gear(k/ph)	Automatic advance
idle	10 (16)	0 to 4 degrees
2,500 RPM	25 (40)	8 to 12 degrees
3,500 RPM	40 (65)	15 to 18 degrees

Ignition coil

The 135.AC.B ignition coil has dual high voltage terminals, one for each spark plug. The coil fires both plugs simultaneously every revolution, on the compression stroke and on the exhaust stroke of each cylinder.

To remove the ignition coil, remove the two bolts fastening the coil to the frame just under the fuel tank.

Reinstall the ignition coil by reversing the sequence of the operations.

Spark plugs

US import URAL[®]s have been EPA certified and delivered with NGK BP7HS plugs or Nippondenso W22FP-U plugs.

In certain situations such as cold starting, the plugs can quickly foul with carbon or soot. The engine should not be run on a fouled plug. The plugs can be cleaned, but it is easier to put in a new set of plugs when on the road. Owners should be advised to carry an extra set of spark plugs.

The lower portion of the plug shell is threaded M14 X 1.25 with an 11 mm length of thread. Spark gap of .040 in. is set between the side electrode and the bottom end of the central electrode. Always use a crush washer when installing a spark plug, preferably a new crush washer.

WARNING: Do not over tighten the spark plug when mounting it on the engine, since this could damage the cylinder head.

The following spark plugs may be temporarily substituted: NGK BP7HS, Bosch W5BC Super, Nippondenso W22FP-U (Stocking part #4021), Autolite 4113, Champion L82YC (Stocking part #328).

8.6 Lights

The lighting equipment installed on the motorcycle is listed in Table 8.6-1.

Table 8.6-1. List of Lighting and Light-Signal Equipment

<i>Equipment</i>	<i>Type</i>	<i>Purpose of lamp</i>	<i>Type of lamp bulb</i>	<i>Lamp power, W.</i>
Headlamp		Far reaching and bright light	UA-H6024	45+40
Speedometer		Lighting of speedometer	UA-BULB-2	2.1
Pilot lamp	1973.3803	Direction indicator pilot lamp	UA-BULB-1	2.1
Ditto	1933.3803	Alternator performance pilot lamp	UA-BULB-1	2.1
	1934.3803	Far reaching light switching	UA-BULB-1	2.1
	1953.3803	Gearbox neutral indication	UA-BULB-1	2.1
Sidecar front lamp		Front side lamp, right hand	UA-BULB-4	8.2
		Front right-hand indicator	UA-BULB-5	25.0
Sidecar tail lamp		Front side lamp, right hand, filament 6 W and stop-light on sidecar, filament 25 W	UA-BULB-4	25+6
		Rear direction indicator right hand	UA-BULB-5	25.0
Motorcycle tail lamp	171.3716	Stop light lamp on motorcycle	A12-21-5	25.0
		Lighting of license plate	UA-BULB-3	5.0
Turn indicator		Turn indicator	UA-BULB-5	25.0
Front	1607.3726010			
Rear	1617.3726010			

Headlight

A single 7" diameter DOT approved dual filament sealed halogen beam headlight is used on the U.S. URAL[®]. The headlight should be adjusted so that the high-beam is horizontal when the motorcycle is in its normal loaded condition.

Stop Light

The stop light is activated by either the front brake lever or the rear foot brake pedal. The stop light switch on the front brake is screwed into the base of the hand brake lever and is fixed with a locknut type 13.3730.

The foot pedal stop light switch Type BK854 is secured on the frame bracket by means of two screws. The switch rod is connected via a spring to the top arm of the foot brake pedal. When installing the stop light switch, see that the spring coupling the switch rod and the brake pedal is not loose.

The stop light should illuminate with initial movement of the brake pedal, and extinguish as the pedal is released. If the stop light either stays on or doesn't come on, adjust the spring tension by moving the stop light switch backwards or forward on the frame & re-tightening the two screws.

8.7 Horn

The motorcycle is equipped with a horn which sounds when ignition is on and the horn button is pressed. The horn can be adjusted with an adjusting screw located at the rear portion of the horn body type C205B.

Horn

A single electric horn is activated by a push button on the left handlebar grip. The horn can be adjusted to maximize sound level.

Type C2055 (Vibration-type)

Current drain at 12 V; 11 - 15A

Frequency at 12 V; 350 - 450 Hz

Troubleshooting

The most frequent cause of troubles in the performance of the horn is a corroded or faulty horn button or dirty horn diaphragm. To remedy the troubles, dismantle and clean the respective assembly units. The horn is adjusted with the adjusting screw located in the rear of the horn body.

8.8 Turn Signals

The turn signals are activated by a switch on the left handlebar grip. The turn signal relay (“interrupter”) is powered directly through one of the fuses on the fuse block, with the circuit completed through either left or right side turn signal lights. On the sidecar motorcycle, the right side turn lights are on the sidecar fender. A single turn indicator lamp on the dashboard flashes with either left or right turn selection.

Troubleshooting

The turn signal relay requires a minimum of 12 volts to function correctly. With the engine not running, a low battery, or with the engine running at too low an RPM, the relay may not cycle. If the turn signals do not work even with 12 volts and both the neutral light and the turn indicator do not work, check the fuse block.

If the turn indicators do not work, but there is power to the relay, test the circuit by momentarily bypassing the relay with an insulated test wire. If bypassing the relay causes the turn lights to illuminate, the fault is in the relay. If bypassing the relay does not activate any of the lights, check the turn switch, and wiring. If the right side functions but not the left, check wire continuity to the left side, and clean the bulb sockets. If the left side functions but not the right, check the sidecar plug. Turn signal units must have ground continuity to the frame.

8.9 Wiring, Switches, Fuses, Connectors

Refer to Appendix # 1.

Electrical wiring on the URAL® is of adequate quality, but connections may come loose or corrode, even on new motorcycles. When any circuit does not function correctly, visually inspect wire runs to ensure that there are no shorts to the frame, and check the related fuses, switches and connectors.

Switches with intermittent operation may just have oxidized contacts, which can often be cleaned by saturating the switch with a contact lubricant such as WD40 and cycling the switch. If lubricating the switch doesn't restore operation, disassemble the switch, clean contacts by scraping to shiny metal, lubricate, and reassemble.

The main fuse block is composed of metal connectors riveted onto a composite "bakelite" insulator. Cracking of the insulator will allow the fuse contacts to lose tension. Cracked insulators can be repaired by gluing with a high-strength "instant" gel adhesive. The metal contacts of fuses must be clean and free of oxidation to reduce electrical resistance.

Some wire connections to assemblies such as turn lights are made by a screw connection in a brass terminal block, which can loosen or oxidize enough to create an open circuit. If there is no power to the center contact in a light socket, check the wire connections at the back of the assembly, tightening the screws to ensure firm contact with the wires. For spade-type connections, disconnecting and reconnecting the terminal will usually clean the contact area to shiny metal. Corroded or oxidized connections should be pulled apart, scraped clean, and lubricated with petroleum jelly.

9 Fuel, Carburetion, Air Intake, Exhaust

9.1 Description and Specifications

Fuel is gravity-fed to the carburetors through a manual valve in the bottom of the tank and via hoses. Carburetors are Keihin Seiki CVK type, with separate enrichment circuits for cold starting. Engine air intake is through a central air filter to flexible intake tubes ("pipes"). Exhaust exits the front of the cylinders through header pipes to the muffler. Some models use two-into-one headers with a single muffler. While most models have two-into-two headers with separate left and right mufflers.

9.2 Fuel Tank, Fuel Valve

The fuel ("gasoline") tank is welded steel. If a fuel tank begins to leak at a welded seam, it is safer and usually more economical to replace the tank than attempt to repair it.

To remove the fuel ("gasoline") tank:

1. Drain fuel out of the tank.
2. Remove the fuel hoses.
3. Remove the driver's saddle, then undo the front and rear bolts fastening the fuel tank. By shifting the tank back and raising it at the rear, it can be removed.

Reinstall the fuel tank in reverse sequence.

Note: Before reinstalling the fuel tank, it is a wise precaution to remove the fuel valve ("fuel cock") and flush any resident debris from the tank outlet.

Inspect the fuel tank for cracks, dents, peeling of paint, etc. The fuel tank can be tested for leaks by submerging it in water with a regulated air hose connected to the fuel fitting, and pressurizing the tank with no more than 6 psi. / 0.4 kgf/cc. A stream of air bubbles indicates a leak.

Clean any rust spots or peeling paint from the outside, sand, prime and repaint.

Dismantle the settling bowl and clean the filter. Inspect the fuel hoses for cracking or swelling, especially on the inside. If the hoses are soft, replace them.

Test the fuel valve with fuel in the tank and a container under the open fuel line to collect fuel. With the valve off, check for leaks and no fuel flow. With the valve on, fuel should flow freely. Select the reserve position and check that fuel continues to flow. Should leaks be revealed, either replace the valve or rebuild it.

To rebuild the fuel valve, dismantle it and lap the valve faces flat. Wash well with detergent and hot water, wipe dry and reassemble.

9.3 Carburetors

For US import models, the current carburetors for 650 cc machines are dual Keihin Seiki 32 CVK -type carburetors, which have been certified for compliance with US EPA requirements.

NOTE: Technical information concerning the Keihin Seiki carburetor is proprietary, and alteration of the carburetor system in any way would violate the E.P.A. approval of the URAL motorcycle. For these reasons, we are unable to provide any information regarding the tuning of the carburetor system. Please treat the carburetor as a sealed unit with no user-servicable internal parts.

Carburetor Function

The function of a carburetor is to deliver a combustible air-fuel mixture to the engine. however, in order to be effective, it must first break the fuel into tiny particles (in the form of vapor) and then mix the fuel with air in a proper ratio so it can burn without leaving excess fuel or air.

Troubleshooting

When the carburetor setting is not correct, various irregularities in engine performance are noticeable. These irregularities can be traced to two basic causes.

When air-fuel mixture is too rich

- The engine sounds dull and idles roughly.
- Engine stalls when enricheners applied.
- Engine performance grows worse as it heats up.
- Removal of the air cleaner improves engine performance somewhat.
- The exhaust gases are sooty.
- The spark plug is fouled (black wet deposit around electrode).

When air-fuel mixture is too lean

- Acceleration is poor, noticeable lack of power at full throttle.
- The performance improves when enricheners closed.
- Engine RPM fluctuates.
- Engine overheats.
- Spark plug burns (blistered white insulator).

Table 9.3-1. Carburetor Troubleshooting Chart

PROBLEM	POSSIBLE CAUSE	CORRECTIONS
Hard starting	Incorrect use of enrichener	Correct use of enrichener
	Clogged fuel filter.	Clean filter.
	Clogged low speed fuel jets.	Disassemble carburetor and chemically clean.
	Clogged vent in fuel tank cap.	Unclog vent or replace cap.
	Float stuck.	Remove float bowl, check float operation and correct or replace.
	Float damaged or leaking.	Replace float.
	Intake air leak.	Check carburetor mounting flanges for air leaks.
	Ignition problem.	Repair, replace or adjust as necessary.
	Low cylinder compression.	Repair, replace or adjust as necessary.
Poor idle or stalling		
	Idle speed adjustments are unequal (twin carburetor models and multi-carburetor models using individual throttle stop adjustments).	Equalize throttle stop settings.
	Clogged idle and low speed air bleed.	Disassemble carburetor and chemically clean
	All causes listed under "HARD STARTING."	

Carburetor Maintenance and Repair

To remove the carburetor:

1. Disconnect the intake branch pipe.
2. Undo the upper union nut of the throttle valve, remove the valve, disconnect the cable, reinstall the throttle valve and cover, and turn the nut back in place.
3. Undo the nuts fastening the carburetor to the cylinder head and remove the carburetor.

To reinstall the carburetor, reverse the sequence of the operations given above.

9.4 Air Filter

The air cleaner and intake pipes help remove airborne dust from intake air, and meter air intake for engine starting.

The air cleaner is a single-stage paper element filter. The air drawn in from the outside through a paper filter before passing to the carburetors.

Air Cleaner Maintenance

As the air cleaner gets contaminated, its flow and filtering capacity is impaired. The air cleaner should be serviced by washing the filter material in solvent or kerosene. In operation, the engine breather will keep the filter material oiled.

To remove the air cleaner, undo the center coupling bolt. Lift the air cleaner up as a unit and pull it out of the frame towards the left. To provide greater clearance for removing the air cleaner, it helps to hold down the kick-starter pedal with your foot. Take care to catch the gasket under the filter.

To reinstall the air cleaner, reverse the sequence of operations, taking care to position the rubber gasket correctly and fit the coupling bolt through the hole in the cross of the plastic casing, and into the threaded boss of the air cleaner housing.

To remove the intake branch pipes:

Unscrew the clamping bands on intake branch pipes and remove them from the carburetor necks and from the air box.

9.5 Exhaust Pipes & Mufflers

Most current URALs use separate exhaust pipes (“headers”) for each cylinder, with a separate muffler (“silencer”) on each side. Some models (e.g. Patrol) and earlier models use a two-into-one system, with a single muffler on the right side. The two-into-two system uses a crossover (“connecting”) pipe between the two mufflers. Both header pipes and muffler are different for the two-into-one system.

To ensure Vehicle Emission conformance, correct carburetor function, safety, and engine reliability, the stock URAL® exhaust system must be retained and kept in good condition. Mufflers which have become damaged, have rusted through, or have been modified will effect engine performance, and should be replaced with stock URAL® components to avoid engine damage and violation of EPA regulations.

To remove the exhaust system

1. Undo the nuts fastening the passenger footrests and those of the engine front stud, slacken off the clamp bolts, and remove the clamps (“clips”) from the stud.
2. Compress the rear suspension and remove the passenger footrests.
3. Take off the union branch pipe, spreading the mufflers ("silencers") apart.
4. Undo the clamping nuts and remove the muffler off the exhaust pipes.
5. Remove the ends of the exhaust pipes out of the cylinder head.

Reinstall the exhaust system in the reverse order.

Note: prior to tightening the muffler clamp nuts, pack heat-proof packing cord under them (wood stove door seal material or muffler packing will suffice).

With the muffler attached and the header pipe in position, tighten the header clamp bolts.

10 REPAIR SUPPLIES

10.1 URAL. Seals

SEALS MOUNTED ON MOTORCYCLE (Table 10.1-1)

Part No.	Description	Location	Qty.
7201025	Crankshaft seal and spring assy	Rear bearing housing	1
6201124	Camshaft seal and spring assy	Distribution box cover	1
7203207-A	Clutch release slider ring	Clutch release slide	1
7203213-2	Seals of: Clutch release rod	Clutch release rod	1
Z101-04038-01.101-04038-01	Kick starter shaft, assy with spring	Gear-box crankcase cover	1
6204010	Clutch shaft, assy with spring	Gear-box crankcase cover	1
6204157	Main shaft	Gear-box crankcase cover	1
6204017	Right-hand cover of gearbox crankcase, assy with spring	Right-hand cover of gearbox crankcase	2/1
7205039	Final drive casing, assy with spring	Final drive casing	1
6205033	Universal joint fork, assy with spring	Final drive bearing nut	1
6206006-10	Rubber packing	Wheel hub	4
Z101-08159	Seal	Steering column	2
Z101-08019	Collar and spring assy	Seal body of fork leg tip	2
Z101-08123	Seal	Seal body of fork leg tip	2
6326152	Container nut seal	Seal casing of spring-loaded hydraulic shock absorber	3
6326155	Rubber seal	Seal casing of spring-loaded hydraulic shock absorber	3

10.2 Lubricants

The table below lists factory recommended substitutes for the Russian lubricants. The URAL. has been certified for EPA with **premium grade SAE 20W/50 petroleum based detergent oil designed for air cooled engines.**

This oil has been used in both the engine and transmission. We suggest at the first service interval that the owner follow the local Authorized URAL. Dealer's recommendations for all lubricants best suited to local conditions.

List of North American Substitutes for Recommended Lubricants

Name of lubricant	Russian Grade	Substitute
Engine & Gearbox Oil	M-8B	Any premium grade SAE 20W/50 petroleum based detergent oil designed for air cooled engines.
Final Drive Oil	TAP-15B, TAD-17I	Any premium grade automotive 90 EP gear oil.
Industrial Oil (Spindle Oil 2)	I12A	Any premium grade light lubricating oil.
Spindle Oil	AY	Any premium grade light lubricating oil.
Grease	LITOL-24	Any automotive chassis grease - preferably lithium based.

When operating the motorcycles in countries with hot and tropical climate, it is recommended to use more viscous oils. If humidity is above normal, use oils with anti-corrosive additives.

10.3 Substitute Parts

Standard North American automotive and aviation supplies may be substituted for any specific Russian sealants, lubricants, abrasives, or cleaners. Automotive bearings of equivalent grade or higher may be substituted for Russian bearings if the same size is available. Metric fasteners from local sources may be substituted for Russian metric fasteners of the same diameter and thread pitch, assuming the replacements are of grade 8 or higher. Where specific supplies and substitute parts are known by **Ural**, they will be listed.

11 Conversion Tables

When it is necessary to convert between Metric and US measurement systems, the following table may be used:

When you know	Multiply by	To find
mm (millimeters)	0.0394	in (inches)
cm (centimeters)	0.3937	in (inches)
m (meters)	3.281	ft. (feet)
m (meters)	1.094	yd. (yards)
km (kilometers)	0.621	mi. (mile)
in. (inches)	25.4	mm (millimeters)
in. (inches)	2.54	cm (centimeters)
ft. (feet)	30.48	cm (centimeters)
cc (cubic centimeters)	0.061	cu in. (cubic inches)
cc (cubic centimeters)	0.034	oz (US fluid ounces)
cc (cubic centimeters)	0.002	pt. (US liquid pints)
cc (cubic centimeters)	0.00106	qt. (US liquid quarts)
L (liters)	1000	cc (cubic centimeters)
L (liters)	0.264	gal (US liquid gallon)
cu in. (cubic inches)	16.387	ml (milliliters)
cu in. (cubic inches)	16.387	cc (cubic centimeters)
oz. (US fluid ounces)	29.574	cc (cubic centimeters)
oz. (US fluid ounces)	0.0296	L (liters)
pt. (US liquid pints)	473.18	cc (cubic centimeters)
qt. (US liquid quarts)	946.35	cc (cubic centimeters)
kmph (kilometers per hour)	0.621	mph (miles per hour-statute)
mph (miles per hour- statute)	1.62	kmph (kilometers per hour)
N.m (Newton meters)	0.738	ft/lb. (foot pounds)
N.m (Newton meters)	8.851	in/lb. (inch pounds)
ft/lb. (foot pounds)	1.356	N.m (Newton meters)
psi. (pounds per square in.)	70.31	grams per square cm

Electrical Symbols

Diode

The diode is a solid-state device which passes electricity in one direction only. Electrons flow through the diode against the direction of the arrow. Diodes typically use 0.7 volts to pass electricity.

Push Button Switch

When the button on the push button switch is pressed, the bar moves down to make a path for the electricity between the two contacts.

Single Pole Double Throw Switch

The switch carries electricity from a single input to none, or one of two possible outputs.

Shorting Switch

The switch carries electricity from a single input to none, one, or both outputs.

Single Pole Triple Throw Switch

The switch carries electricity from a single output to one of three possible outputs. If two or more switches are ganged, then they move together with each other.

Resistor

Passive device used to reduce the flow of electricity from one part of a circuit to another.

Coil

Many turns of wire which act as an electromagnet when electricity flows through the wire.

Fuse

A fuse is a fusible link of metal that is designed to melt if more than the rated amount of power is passed through the device. The melting of the fuse will immediately stop the flow of electricity in a circuit. Fuses are rated in "Amps"

Electrical Circuits

Lead acid batteries such as those found in motorcycles are designed for a charging voltage of 14.25 volts. Batteries which are subjected to greater than 14.25 volts for extended periods of time can suffer permanent

damage due to the electrolyte boiling dry. Charging voltage of less than 14.25 volts will result in an inadequate charge delivered to the battery.

Automotive batteries operate at 12 volts. This is not enough voltage to harm people in any way. However, the battery stores a huge amount of electricity in the form of electrons. If the electrons are allowed to flow from the battery without restriction, then the wires carrying the electricity will become hot enough to melt. The melting wires are extremely dangerous and can easily burn you.

Most problems in automotive electrical circuits are caused by poor connections. Make sure that all connection points are clean and tight.

If the flow of electricity through a wire is interrupted due to a break in the wire or a poor connection, then the circuit is said to be “an open circuit”

The flow of electricity through a circuit always takes the path of least resistance. If there is an accidental path of extremely low resistance created in a circuit, the circuit is said to have a “short circuit” A short circuit will usually result in the melting of the fuse protecting that circuit.

ClassicCycles.Org

Top Fuse
In Fusebox

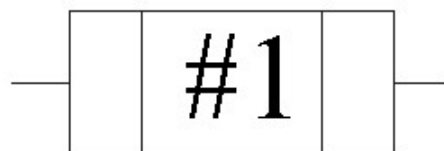

Electronic Ignition
Electric Start Relay

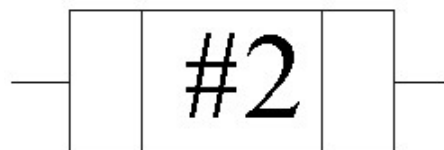

Horn
Brake Lights

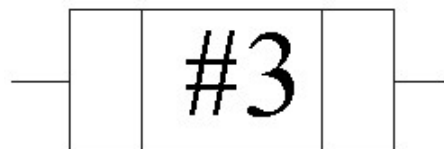

Headlight
Hi Beam Indicator Lamp
Speedometer Illumination Lamps
Running Lights



(If Ign. switch in "Park" position #3)
Sidecar Front Running Light
Sidecar Rear Running Light
Headlight Running Lamp (Optional)

Bottom Fuse
In Fusebox

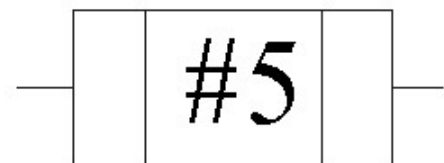

Neutral Light
Turn Signals
Alternator Fault Indicator Light

Hidden In-line Fuse
Behind headlight

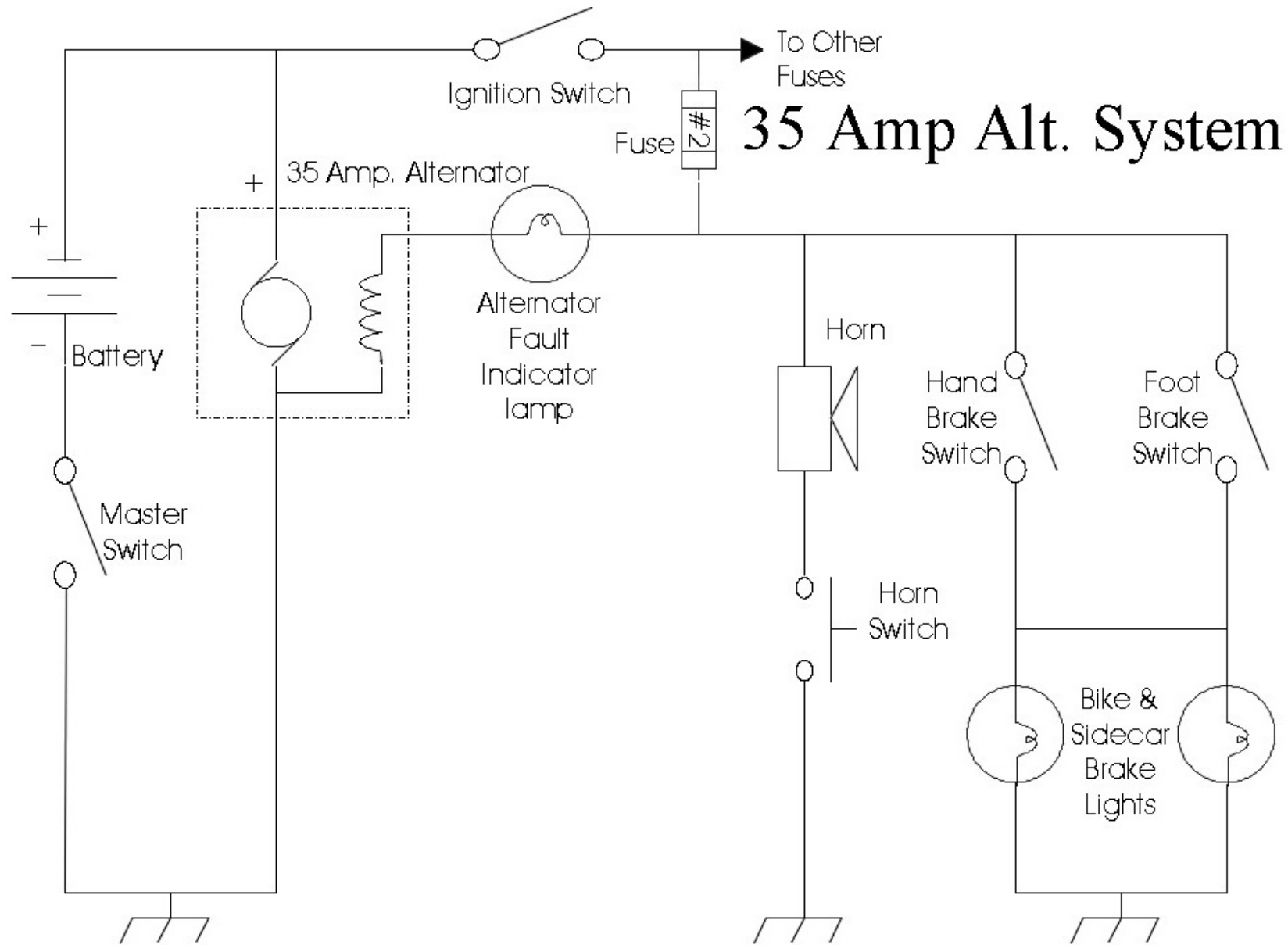

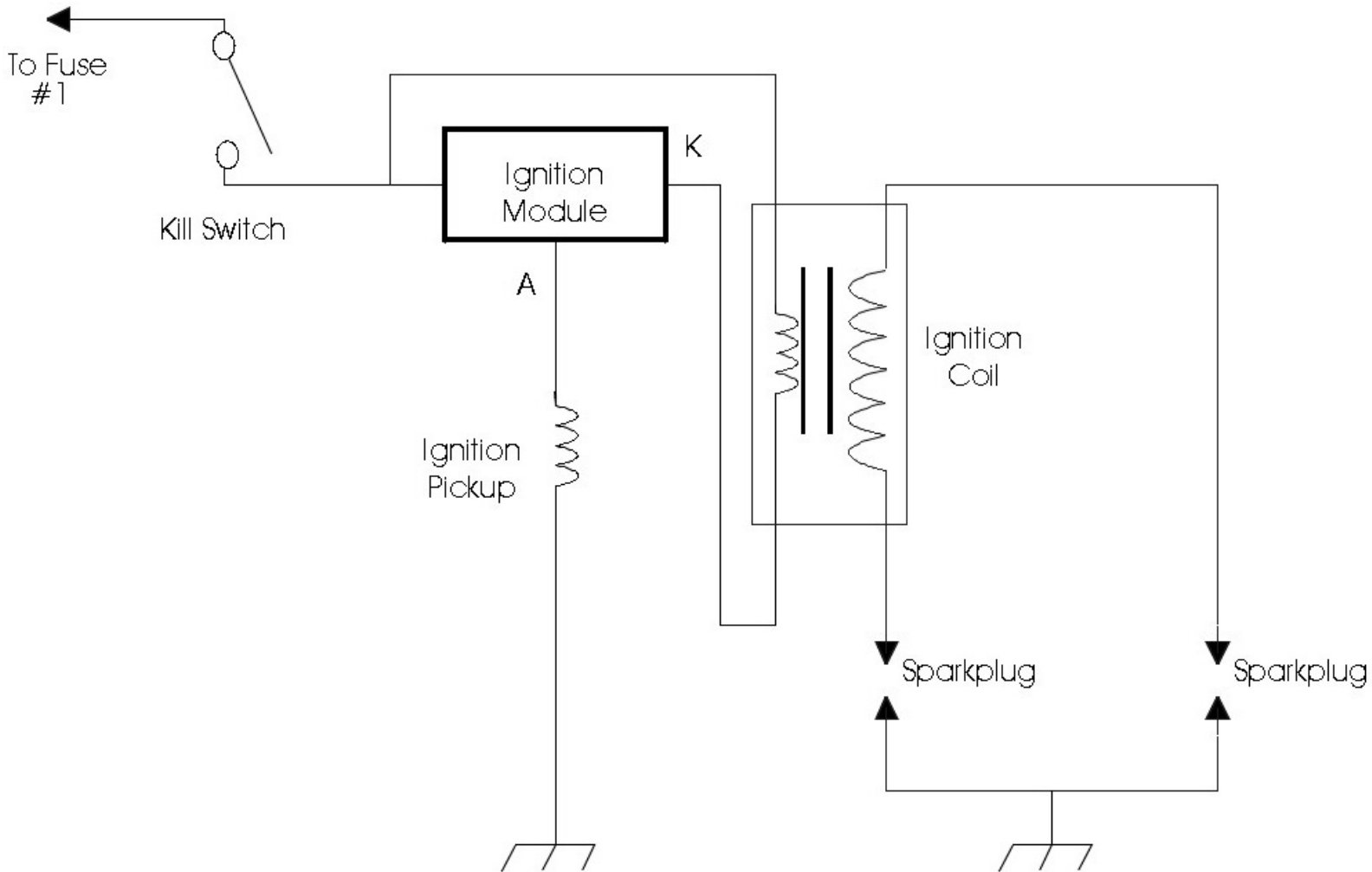

Ignition & Day/Night Switch

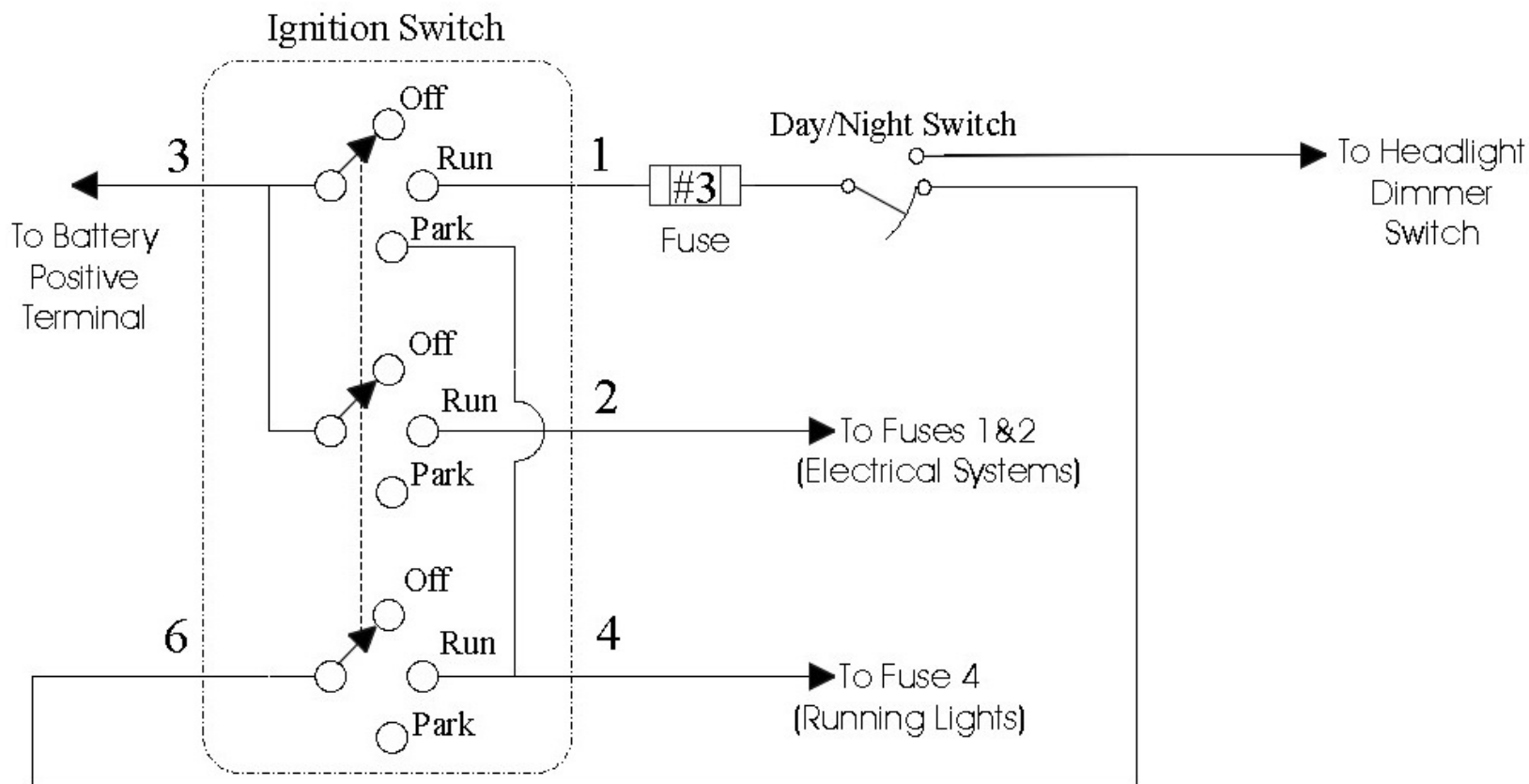

Headlight Wiring

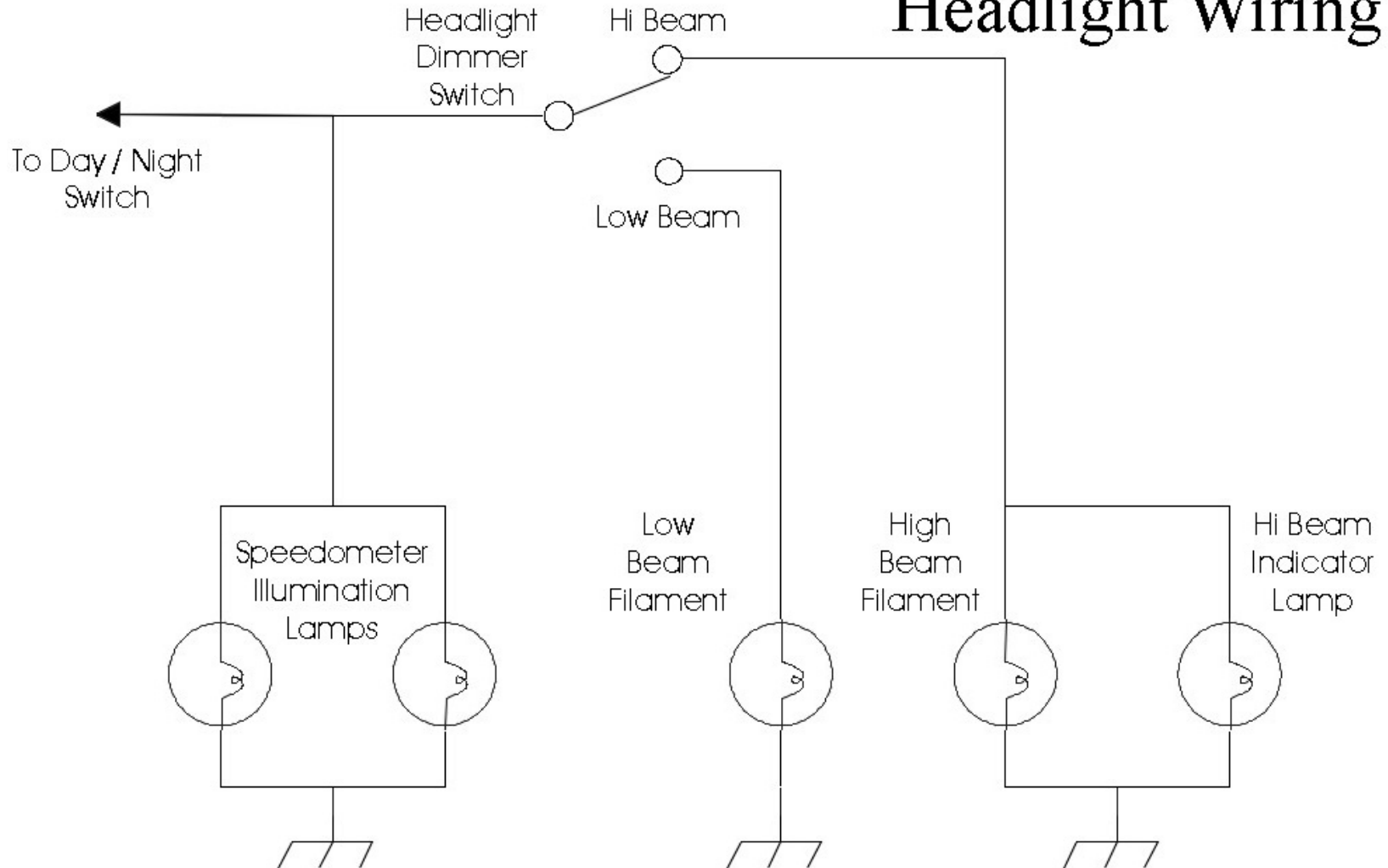

Running Lights

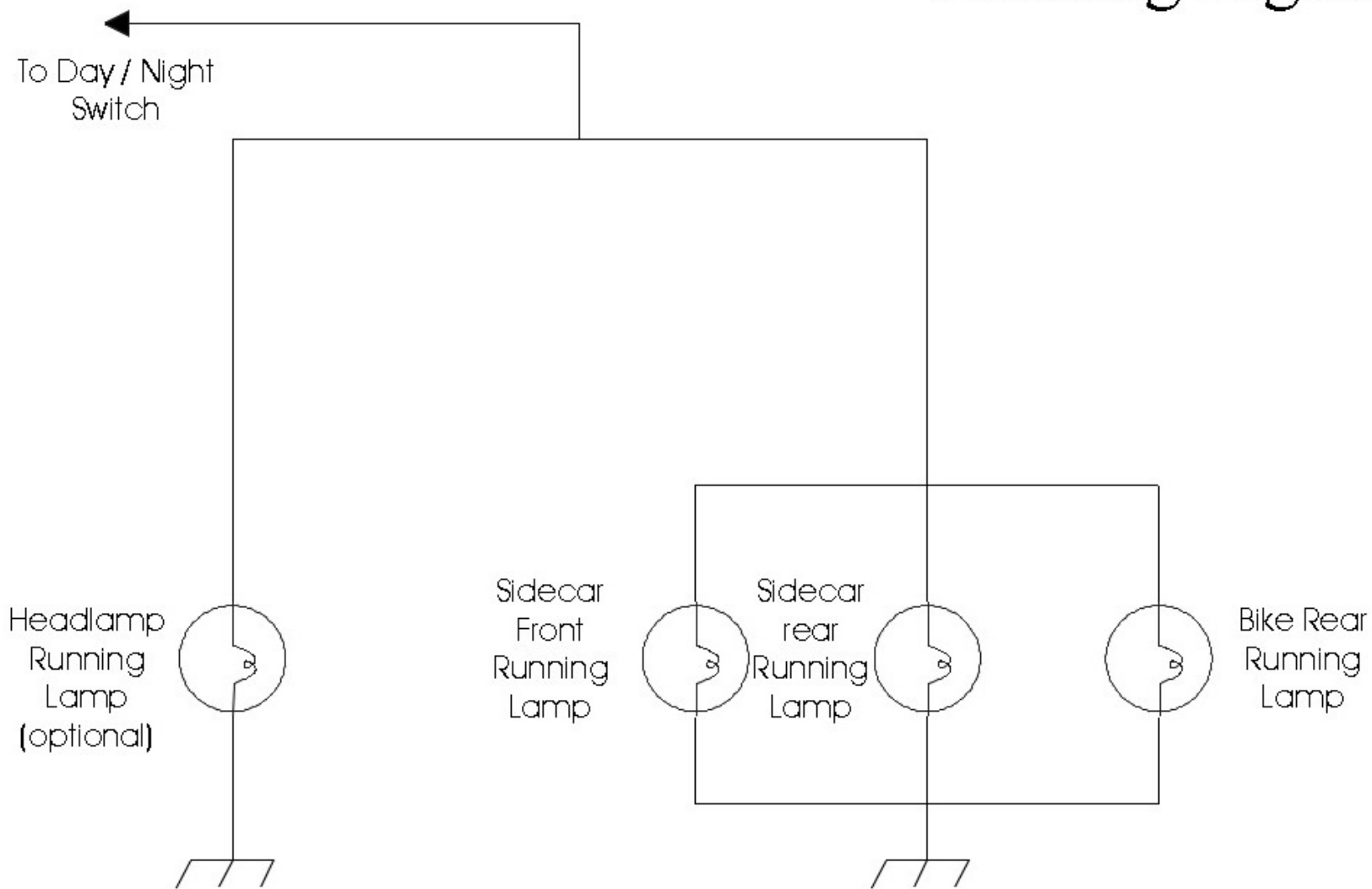

Turn Signals

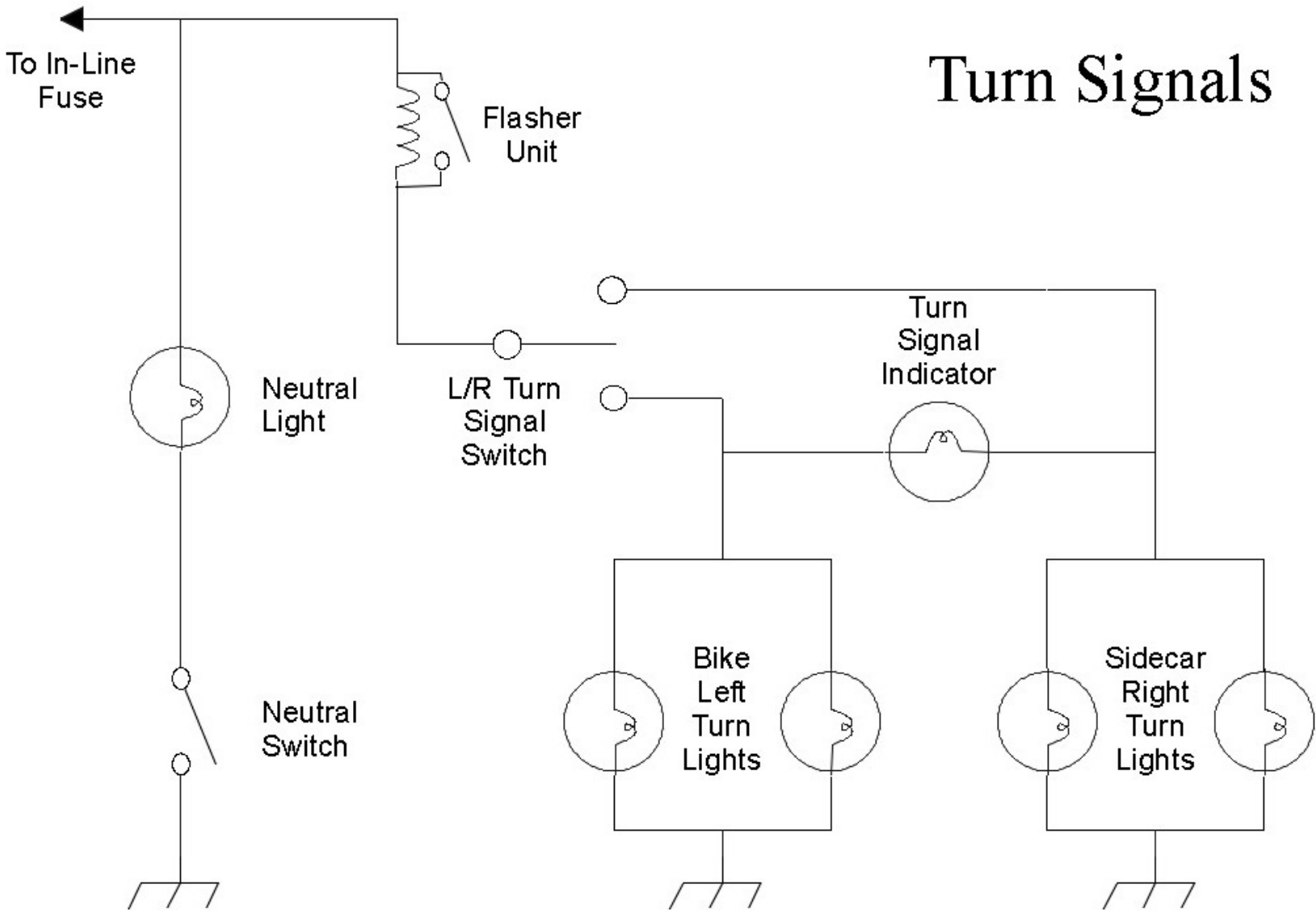

E-Start System

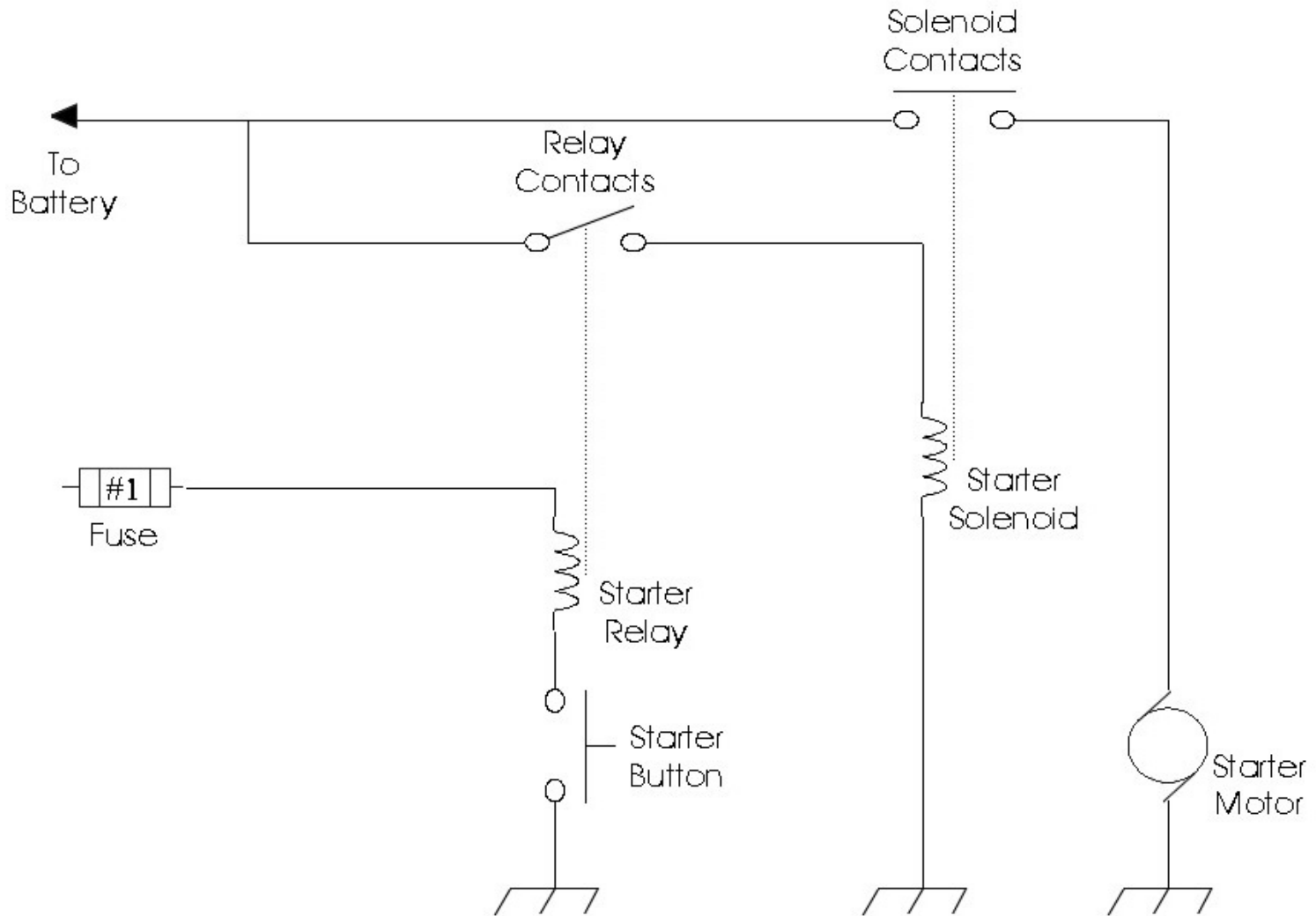

Electrical Sub-Systems Troubleshooting Guide

- 1) Turn on the master switch. Turn the ignition switch to the middle “on” position. Press the horn button. Did the horn sound?
No - Go to step 2.
Yes - Go to step 6.
- 2) Check for 12 volts between the metal frame of the motorcycle and each electrical terminal of the horn. Did you measure 12 volts on one of the two terminals?
No - Check the fuse holder assembly for bad fuses or poor electrical connections. Go to step 3.
Yes - Check the horn switch and it’s wiring for proper operation. Replace as required. Go to step 3.
- 3) Check the horn operation again. Did the horn sound this time?
No - Adjust the adjustment screw on the horn until the horn operates. Go to step 4.
Yes - Congratulations, you fixed the horn circuitry.
- 4) Check the horn operation again. Did the horn sound this time?
No - Go to step 5.
Yes - Great! You fixed it!
- 5) Using an ohmmeter measure the resistance of the horn between its two connectors. Is the resistance of the horn approximately 5 ohms?
No - Replace the horn.
Yes - Go back to step 1. You’ve missed something.
- 6) Make sure the bike is in neutral. Did the neutral indicator light illuminate?
No - Go to step 7.
Yes - Go to step 8.
- 7) Use a short piece of wire to ground the contact of the neutral switch to the bike frame. Did the neutral light illuminate when the contact was grounded?
No - Check the fuses, the indicator bulb and it’s wiring. Also check the wire that connects the indicator lamp to the neutral switch and look for a break in the wire. Check that the connection of the wire to the neutral switch is clean and tight. DO NOT OVERTIGHTEN THE NUT on the switch contact or you will mis-adjust the neutral switch!
Yes - Use the instructions in the repair manual to adjust the neutral switch. Go to step 8. See photo on next page.



- 8) Shift the transmission into 1st gear. Did the neutral light extinguish?
No - Check the wire that connects the transmission switch to the indicator light. Look for bare wire showing. Adjust the neutral switch if required.
Yes - Normal operation of the neutral switch. No problem indicated.

Lighting Circuit Troubleshooting Guide

- 1) Turn the ignition key to the middle “on” position. Does anything electrical work at all?
No - Go to step 2
Yes - Go to step 5
- 2) Is the master switch in the “on” position?
No - Turn the switch to the “on” position. Go to step 1
Yes - Go to step 3
- 3) Check the battery voltage. Is the battery voltage approximately 12 volts?
No - Charge the battery.
Yes - Check the battery terminal connections. Clean and tighten connectors. Go to step 4
- 4) Is everything electrical still dead?
No - Problem solved. You’re an electrical genius!

Yes - Check the wire from the battery to the ignition switch and the ignition switch. Replace as required.

- 5) Does the headlight Lo beam illuminate?
No - Check the fuses, headlight switch & sealed beam unit. Replace as required.
Yes - Go to step 6
- 6) Move the headlight switch to the Hi position. Does the Hi beam indicator illuminate?
No - Check the headlight Hi / Lo switch & indicator light bulb. Replace as required.
Yes - Go to step 7
- 7) Does the headlight Hi beam illuminate?
No - Replace the sealed beam unit.
Yes - Go to step 8
- 8) Are any of the running lights working?
No - Check for bad wire connections in fuse holder assembly. Repeat step 8.
Yes - Replace defective bulbs as required. Go to step 9.
- 9) Activate the left turn signal switch. Is at least one left turn signal light flashing?
No - Go to step 10
Yes - Replace any bulbs if required. Go to step 10.
- 10) Activate the right turn signal switch. Is at least one right turn signal light flashing?
No - Check the fuses, (note that there is a hidden fuse behind the headlight bucket which supplies power to the turn signals) turn signal bulbs & turn signal flasher unit. Replace as required.
Yes - Replace left or right turn signal bulbs as required. Go to step 11.
- 11) Observe turn signal indicator light. Does it appear to operate normally?
No - Check indicator wiring and bulb. Replace as required. Repeat step 11.
Yes - Go to step 12.
- 12) Squeeze the front brake lever. Does at least one brake light illuminate?
No - Go to step 13.
Yes - Replace brake light bulbs if required. Go to step 13.
- 13) Step on the rear brake peddle. Does at least one brake light illuminate?
No - Check for bad wire connections and bad fuses in fuse holder assembly. Replace brake light bulbs if required. Adjust or replace rear brake switch if required. Go to step 14.

Yes - Replace brake bulbs if required. Check front brake switch & wiring Replace if required. Go to step 14.

14) Is the speedometer illuminated?

No - Check the wiring on the back of the speedometer and replace the speedometer bulbs if required.

Yes - End of lighting circuit tests.

Charging Circuit Troubleshooting Guide

1) Turn the ignition switch to the middle “on” position. Observe the red charging fault indicator lamp. Is the lamp illuminated?

No - Go to step 6

Yes - Go to step 2

2) Start the engine and observe the red charging fault indicator lamp. Is the lamp illuminated?

No - Normal operation of charging system. No fault observed. Normal operating voltage for the electrical system with the engine running will be 14 volts \pm 0.5 volts.

Yes - Go to step 3.

3) Observe the alternator shaft. Is it turning?

No - Make the required mechanical repairs.

Yes - Go to step 4.

4) Stop the engine. Remove the alternator unit. Remove the rear cover.

Remove the voltage regulator & brush assembly. Are the brushes excessively worn?

No - Go to step 5.

Yes - Replace the brushes.

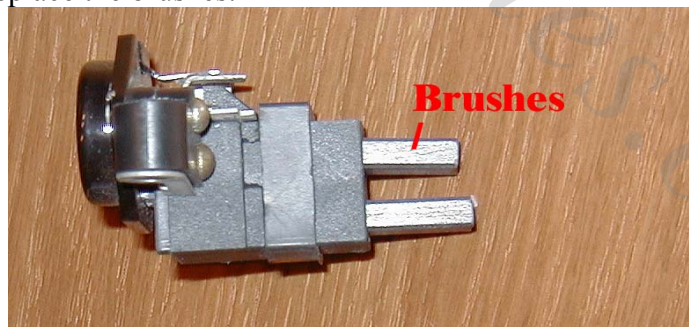

5) Carefully inspect the voltage regulator assembly for broken solder joints.

Do the solder joints appear to be OK?

No - Resolder the connections and test alternator. Go to step 1

Yes - Replace alternator unit.

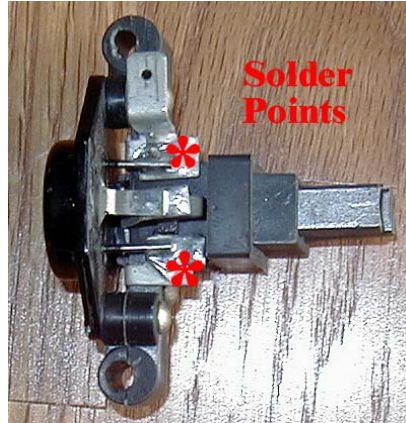

- 6) Remove the small wire with the automotive connector on the end from the rear alternator cover. Ground the connector on the wire to a metal part of the engine using a short length of wire if required. Did the red alternator fault lamp illuminate when you grounded the wire's connector?
No - Check the red lamp and it's wiring. Check fuses also.
Yes - Alternator unit is faulty. Clean all connections to alternator and make sure that alternator body is well grounded to engine casing. Otherwise replace the alternator unit.

Starting Circuit Troubleshooting Guide

Perform the following tests either outside or in an area where there is adequate ventilation, and ensure that there is no source of ignition near the motorcycle!

- 1) Turn on the master switch. Turn the ignition switch to the middle "on" position. Turn the fuel petcock to the "on" position. Pull out the choke knob on each carburetor. Press the electric start button. Did the electric starter motor do anything?
No - Go to step 2.
Yes - Go to step 3.
- 2) Press the starter button again. Listen for a click sound under the seat. Did you hear a sound?
No - Go to step 10.
Yes - Go to step 10.
- 3) When the motor was turning over, could you hear either cylinder fire at all?
No - Go to step 4.
Yes - Exchange the spark plugs and leads between cylinders by reversing the positions of the spark plug leads at the ignition

coil. If the problem follows either the spark plug or lead to the other cylinder, then replace the defective component as required. If the problem remains with one cylinder then suspect either the carburetor or valve adjustments. Go to step 5.

- 4) Pull the spark plug from each cylinder and lay the plugs on top of the cylinder heads so that the threaded part of the plug makes electrical contact with the bare metal of the cooling fins. Press the electric start button again and look for sparks jumping across the spark gaps. Did you see sparks on either of the spark plugs?
No - Go to step 7.
Yes - Go to step 5.
- 5) Remove the fuel supply hoses from each of the carburetors. Did you see an unrestricted flow of gasoline pour out from the ends of the hoses?
No - Go to step 6.
Yes - Let the engine sit with the spark plugs removed for 30 minutes to dry out. The cylinders may be flooded.
- 6) Momentarily remove the fuel supply hose from the fuel petcock under the fuel tank. Was there an unrestricted flow of fuel from the fuel petcock? (Make sure the fuel petcock is turned on)
No - Fill the fuel tank with fuel and go to step 1
Yes - Check the fuel supply hoses and fuel filters for restrictions. Reconnect the fuel lines and filters and go to step 5.
- 7) Use a voltmeter and check for +12 volts on the red wire of the ignition module located under the front engine cover. Did you measure +12 volts with the other lead of the voltmeter connected to the metal of the engine?
No - Check the fuses and look for poor wire connections in the fuse holder assembly. Also make sure that the kill switch is in the run position. Repeat step 7.
Yes - Go to step 8.
- 8) Use an ohmmeter to check the ignition coil. Measure the resistance of the primary winding by attaching the ohmmeter leads to the outside studs of the ignition coil. The meter should read approximately 1 ohm. Now measure the resistance of the secondary coil by connecting the ohmmeter between the two extending high voltage output connectors of the coil. The resistance should be approximately 7,700 ohms. Are the resistance characteristics of the ignition coil close the above values?
No - Replace the ignition coil.
Yes - Go to step 9.

- 9) Check the electronic ignition assembly for any loose wires. The disk with the steel pins must spin with the motor crankshaft. The gap between the timing disk and the timing sensor must be .010 inches. Are there any visible problems?
No - Replace the electronic ignition module.
Yes - Correct the problems and if required, return to step 3.
- 10) Locate the starter relay mounted under the rider's seat. Connect a voltmeter to the two connectors of the starter relay. Press the start button and measure the voltage at the relay's connectors. Did you measure 12 volts?
No - Check the wires going to the relay for loose connections or a break in the wire. Check the electric start switch for correct operation. Replace the switch if required.
Yes - Check the wire that carries the 12 volts from the output of the starter relay to the starter solenoid. Look for loose or dirty connectors or a break in the wire. Go to step 11.
- 11) Use a screwdriver to carefully form a jumper between the starter solenoid tab and the starter solenoid stud which has the wires connected to it. Did the starter solenoid motor activate?
No - Go to step 12.
Yes - If the starter motor activated with the screwdriver bypass but not with the electric start button then there are several things which need to be checked. Start with the fuse holder assembly. Look for any blown fuses or poor wire connections on the ends of the fuse holders. Look for green corrosion or loose wires. Remove the electric start switch from the bike & look for internal signs of broken switch contacts. Look at the switch connector also and make sure that it makes good contact. Look under the rider's seat of the bike behind the master switch. There you will find a small relay which is controlled by the electric start switch. When activated, the relay sends 12 volts to the tab on the starter solenoid. Check for loose connections on the relay or broken wires going to / from the relay. If you are unable to find a problem with the start switch, fuses, or wiring then replace the relay. Otherwise, replace as required.



- 12) Turn off the master switch. Remove the heavy wire that leads to the battery from the stud connector on the starter solenoid. ***Hold it in your fingers so that there is no possibility of it touching anything metal on the bike!!*** Turn the master switch back on. Briefly tap the metal connector in your fingers to the other metal stud connector on the starter solenoid that is closest to the starter motor. Did the motor start momentarily? Turn off the master switch and return the heavy wire to its original terminal.

No - Replace or repair the starter motor

Yes - Replace the starter solenoid.



- 12) Turn off the master switch. Remove the heavy wire that leads to the battery from the stud connector on the starter solenoid. ***Hold it in your fingers so that there is no possibility of it touching anything metal on the bike!!*** Turn the master switch back on. Briefly tap the metal connector in your fingers to the other metal stud connector on the starter solenoid that is closest to the starter motor. Did the motor start momentarily? Turn off the master switch and return the heavy wire to its original terminal.
- No - Replace or repair the starter motor
 - Yes - Replace the starter solenoid.